



Self-Priming Pumps



S-Series & I-Series



ONE PRODUCT ALL SOLUTIONS

All Prime is a product manufactured using the most advanced technology. The design permits easy and fast access to inside parts, to clean up and for easy handling. This pump is totally interchangeable with several other similar pumps. All Prime is the result of more than two generations of skilled professionals globally specialized in the pump industry. The result of this union of generations is a product that can be used in a wide variety of pumping applications.

MAINTENANCE

EASY AND FAST

All Prime Pump normal maintenance activities can be done quickly and easily using standard hand tools - saving time and money.

ADJUSTMENT

SHIM-LESS EXTERNAL IMPELLER

An easy to use external impeller clearance adjustment system allows the impeller and wear plate to operate with optimum clearances without disassembly. Using only common hand tools, the pump can be maintained at peak efficiency to extend both impeller and wear plate life.



AUTOMATIC SELF-PRIMING

NO SUCTION CHECK VALVE REQUIRED

The All Prime I and S series pumps are equipped with a suction check valve but do not require the check valve to be in place to re-prime. The large volume of liquid carried in the volute allows dry suction re-priming.

INSPECTION AND CLEANING

WITHOUT DISTURBING PIPING

An advantage of the All Prime Pump is that the front clean out cover and the rotating assembly can be removed without disturbing the piping, allowing inspection and cleaning in place with little effort. Both I and S series pumps have this feature.



CONSTRUCTION MATERIAL

	CI-STD	CI-316	CI-304	CI-CD4	CI-ADI	ADI	316SS	304SS	CD4
Casing	A48 CL30					ADI	316SS	304SS	CD4MCU
Cover-Plate	A48 CL30					ADI	316SS	304SS	CD4MCU
Bearing Housing	A48 CL30					ADI	316SS	304SS	CD4MCU
Flanges	A48 CL30					ADI	316SS	304SS	CD4MCU
Impeller	A60-40-18	316SS	304SS	CD4MCU	ADI	ADI	316SS	304SS	CD4MCU
Wear-Plate	SAE1020 / A48CL30	316SS	304SS	CD4MCU	ADI	ADI	316SS	304SS	CD4MCU
Seal-Plate	A48 CL30	316SS	304SS	CD4MCU	ADI	ADI	316SS	304SS	CD4MCU
Shaft	ANSI 4140HT	ANSI 17-4PH			ANSI 4140HT		ANSI 17-4PH		
C.V. Flapper	NEOPRENE	VITON			NEOPRENE		VITON		
O-Rings	BUNA	VITON			BUNA		VITON		
Shaft Sleeve	4130	N/A			4130		N/A		
Mechanical Seal	316SS, Viton, Tungsten / Titanium Carbide								

S-LINE

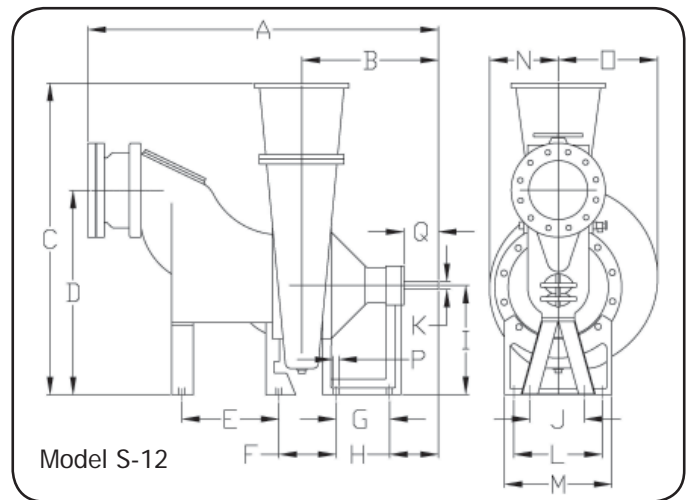
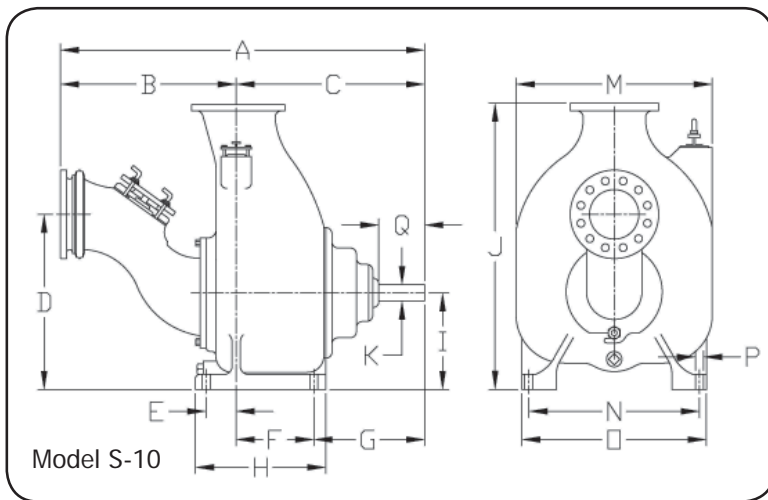
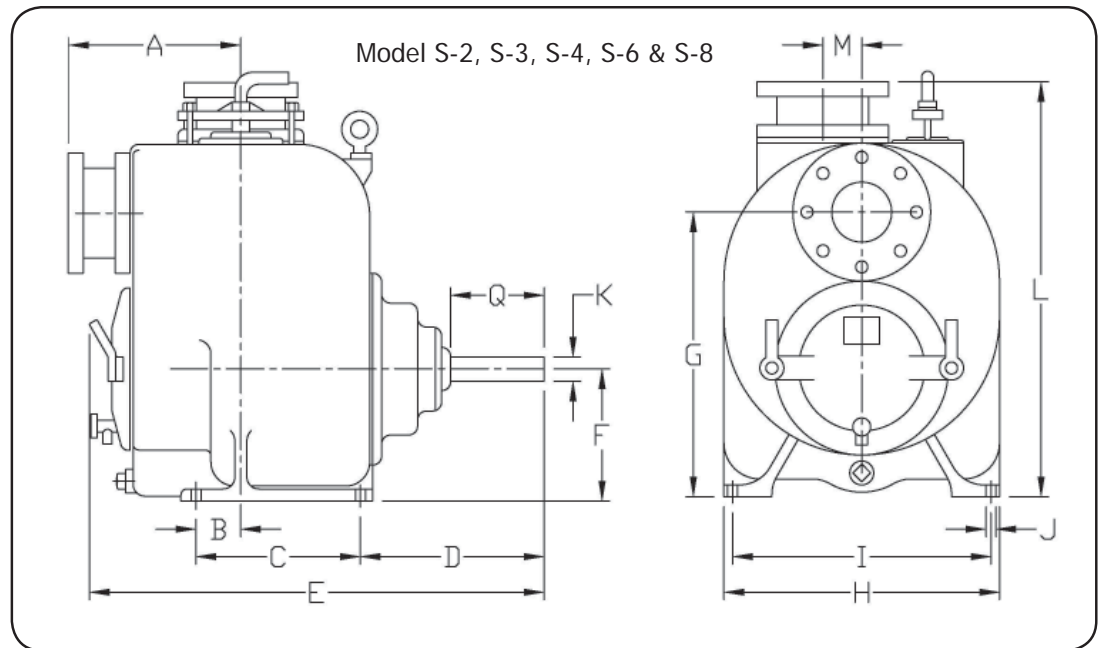

MODELS	S-2	S-3	S-4	S-6	S-8	S-10	S-12
A	9.25	11.56	12.50	16.00	16.25	48.71	63.84
B	2.13	3.00	3.06	3.06	4.00	28.03	25.54
C	6.43	9.00	11.00	11.00	12.00	20.68	56.08
D	10.83	11.19	11.56	11.56	16.03	25.06	38.25
E	21.54	26.31	30.25	31.56	40.28	4.00	20.00
F	5.97	7.50	8.75	10.13	13.00	8.00	10.63
G	12.52	17.00	19.50	22.38	28.50	12.68	8.00
H	12.14	17.00	19.75	22.75	27.75	15.00	10.73
I	11.06	15.50	18.00	20.75	25.00	14.00	20.00
J	0.56	0.69	0.69	0.69	0.88	41.00	9.56
K	1.50	1.50	1.50	1.50	1.75	1.75	2.75
L	20.59	27.06	29.25	35.31	42.06	-	16.00
M	2.75	2.75	2.75	2.75	-	30.94	20.00
N	-	-	-	-	-	25.00	13.62
O	-	-	-	-	-	27.75	18.38
P	-	-	-	-	-	0.88	1.13
Q	4.00	4.00	5.00	5.00	6.69	4.81	6.59

I-LINE

ADVANTAGE OF SELF-PRIMERS

Logistics

- No confined space entry required
- Pump located outside the wet well for easier & cleaner access
- No heavy lifting equipment required for repairs
- Powered by standard NEMA motors

Maintenance

- Removable suction cover allows quick unclogging of pump
- Primary wear parts: seal, impeller & wear plate can be changed through removable suction cover
- Rotating assembly easily removed for shop repairs without disturbing piping

Design

- Rugged open impellers for solids handling to 3"
- Both speed & impeller trim can be employed to meet service conditions
- Impeller design keeps seal pressure low & reduces solids buildup in stuffing box
- Suction flapper check valve speeds self-priming and eliminates foot valves

The principle characteristics of the I-Series are high efficiency, diverse construction materials, multiple speed operation, easy and quick maintenance and operation.

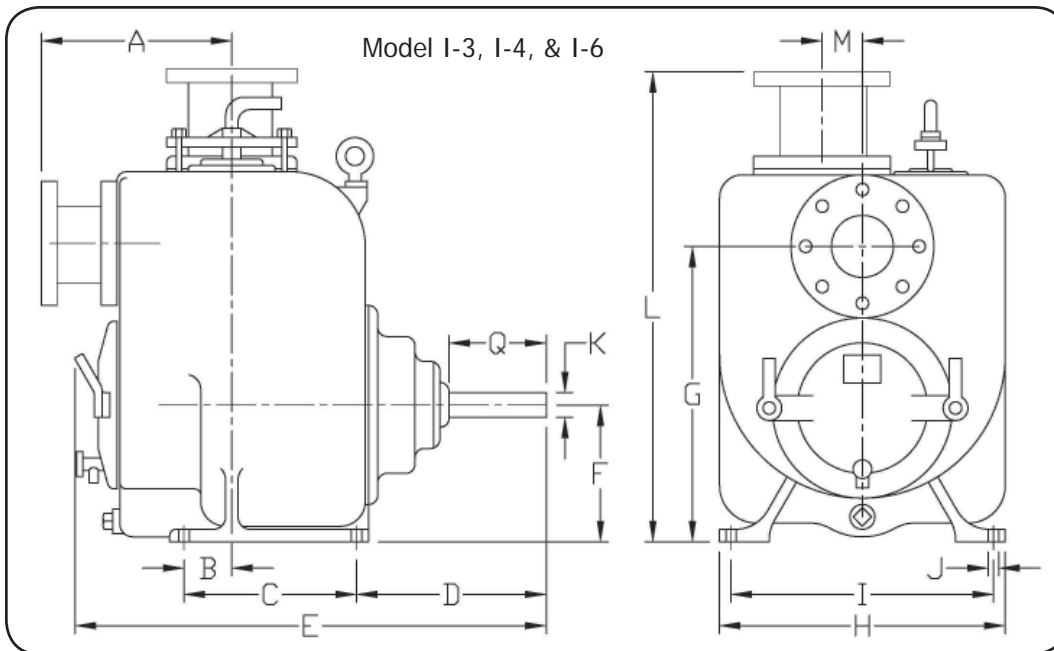

MODELS	I-3	I-4	I-6
A	11.50	12.50	16.00
B	3.00	3.81	3.06
C	9.00	11.00	11.00
D	11.14	11.71	13.02
E	26.25	29.59	33.25
F	7.50	8.75	10.13
G	17.00	20.00	22.38
H	17.00	20.00	23.00
I	15.00	18.00	20.75
J	0.69	0.69	0.69
K	1.50	1.50	1.75
L	27.04	29.68	35.32
M	2.75	2.75	2.75
Q	4.06	4.96	4.50

Base mounted horizontal or vertical v-belt driven & direct coupled package units available.

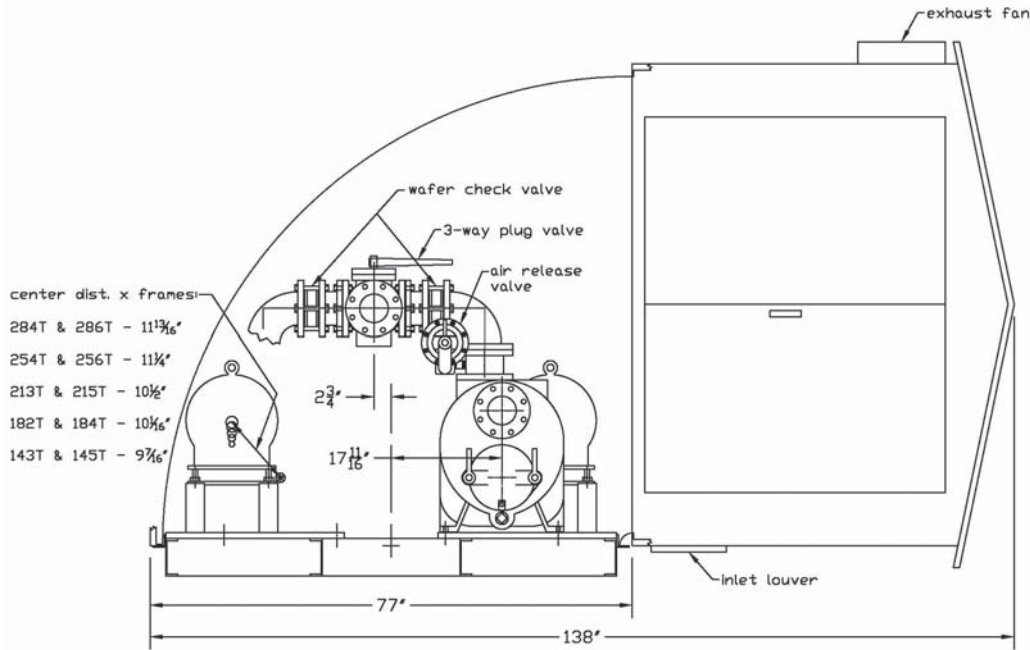
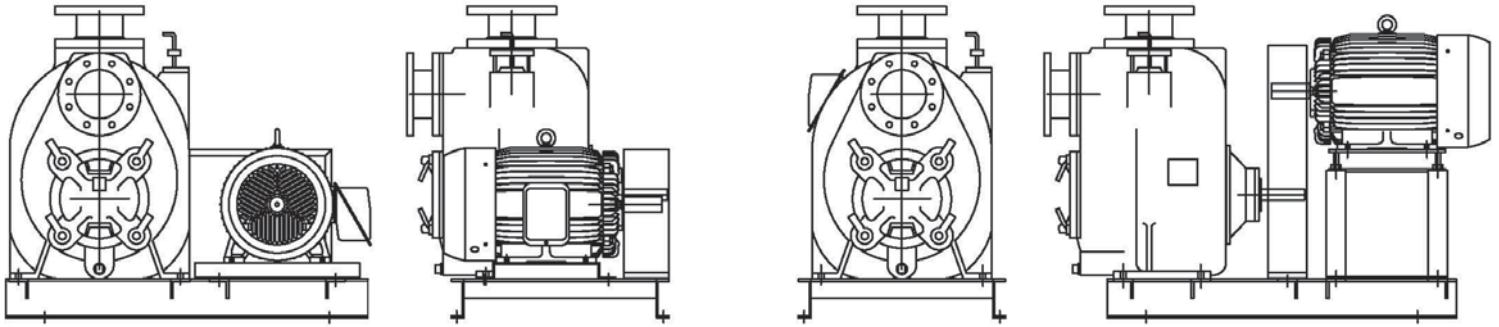

**S-4 Duplex Pump Station
open for heavy maintenance**

Duplex lift station packaged complete
with controls & piping in easy access
6' x 6' fiberglass enclosure.

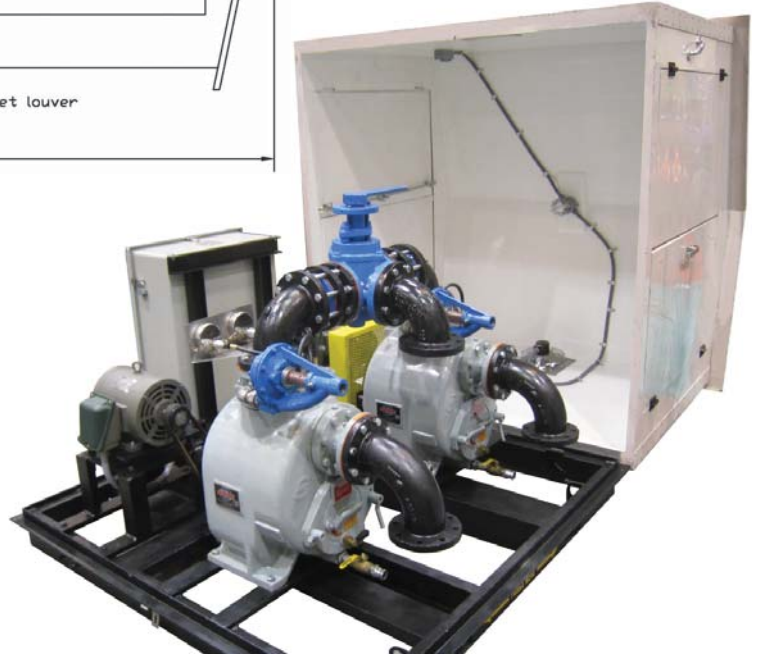

Distributed By:



ALL PRIME PUMPS

division of Power & Pumps, Inc.

803 N. Myrtle Ave.

Jacksonville, FL 32204

p. 800-803-0353

p. 904-356-5881

f. 904-356-8717

sales@allprimepumps.com

www.allprimepumps.com

May.2013