

# MegaRoyal Series Process Diaphragm Pump

- To transport hazardous chemicals at high pressure and flowrate in petrochemical and chemical processes
- Can be used in other industries which require zero-Leakage transportation of critical process liquids
- Modular design provide ease of installation and maintenance
- Compact design makes it suitable for space constraint applications

## Specifications

- Maximum capacity: 60m<sup>3</sup>/h (1000 L/min)
- Maximum discharge pressure: 400 bar
- Maximum motor power: 75kW
- Temperature: -30°C~+150°C (-22°F ~ +302°F)
- Capacity adjustment: By variable frequency drive (VFD) with variable frequency motor

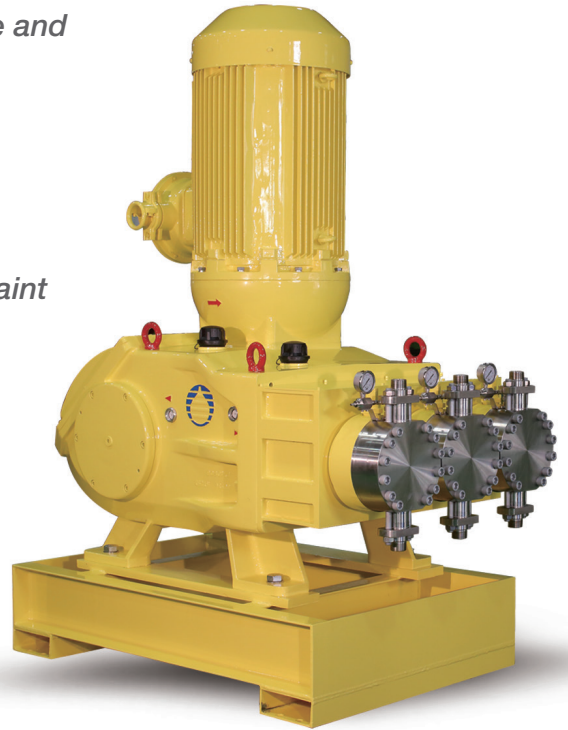

## Applications

- Use in oil and gas industries for high pressure liquid injection and transportation
- Zero-leakage liquid transportation of high pressure and flowrate in petrochemical process application
- Injection and transportation of dangerous chemicals
- Zero-leakage liquid transportation of high pressure and flowrate for key processes of other industries
- Slurry fluid transportation, such as bauxite, coal water slurry and sewage

## Flow and pressure range

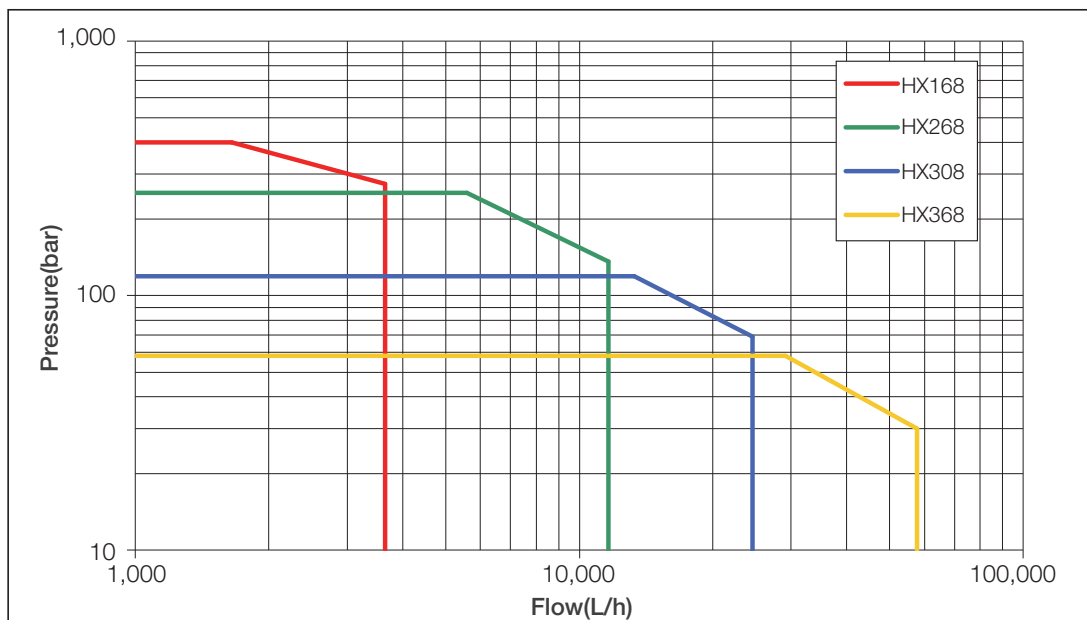

## Features

### Compact Drive End

*Built-in worm gear reducer, compact structure, space saving*

#### Benefits

- Wearproof copper alloy worm gear, longer service life
- Moving parts lubricated in oil bath, reducing wear
- Connecting rods with standard bearing for convenient maintenance
- Unique cross-head seal structure eliminates leakage
- Forged alloy steel crankshaft is strong and durable
- Advanced bearing configuration, provide stable movement
- Cooling design for drive end, decreasing oil temperature

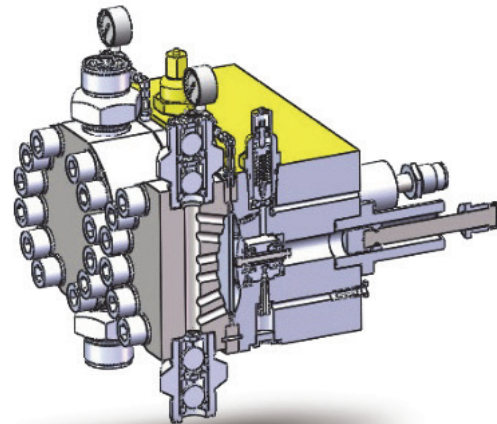

### Unique Liquid End

*High performance hydraulic diaphragm pump*

#### Benefits

- Leak free
- Patented diaphragm design, service life is over 20,000 hours
- Built-in pressure relief valve provides overpressure protection, adjustable pressure setting
- Integrated air-bleed valve, accurately control flow
- Patented MARS refill system, automatically control the compensated hydraulic oil volume, reliably protect diaphragm
- Double diaphragm rupture detection system, available local or remote alarm

### Options

*Variety of special designs available, at utmost to satisfy customer*

#### Benefits

- Special designed suction and discharge valves
- Low temperature
- High temperature
- Jacket insulation
- Slurry application
- Variety of diaphragm material
- Special corrosion resistant material

## Outline Dimensions

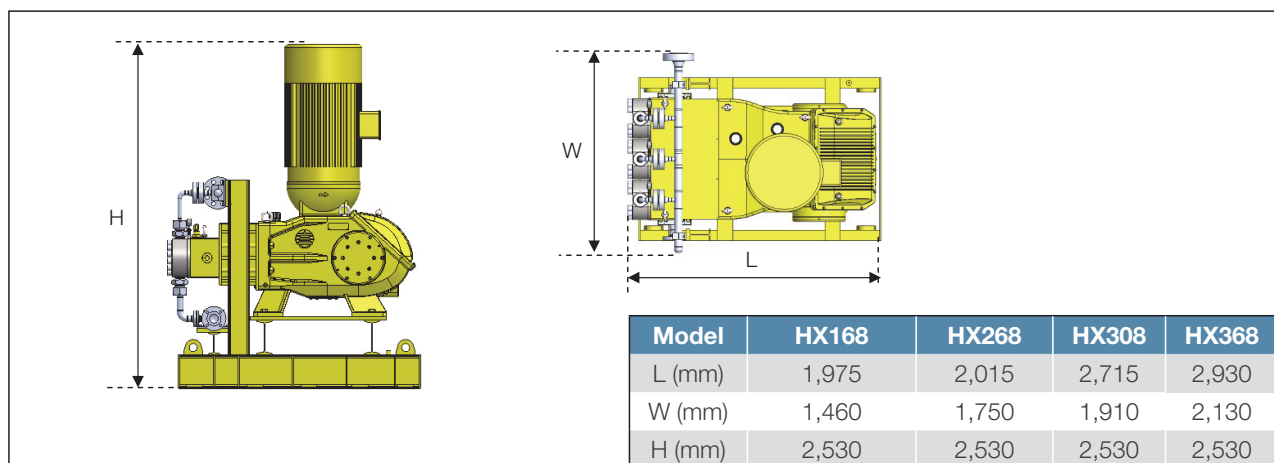

Contact Us

Shanghai: 86 21 61211600

Singapore: 65 6568 2800