

FDA COMPLIANT PUMPS

SPFP05PPT – 1/2"

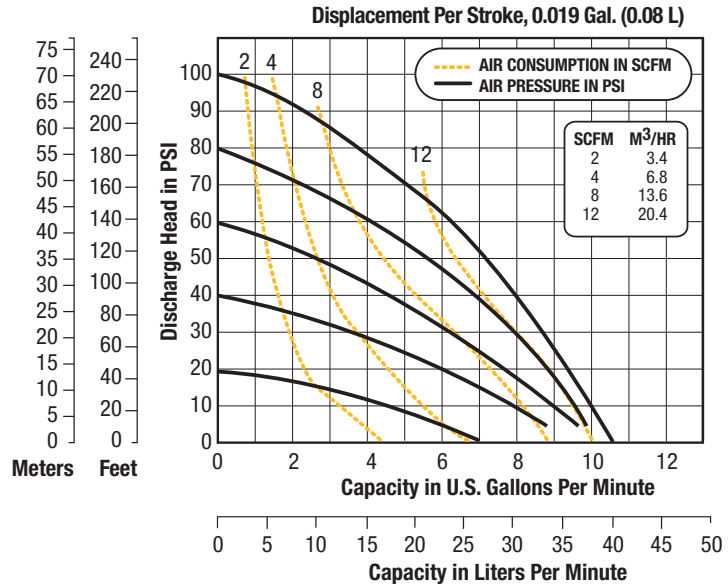
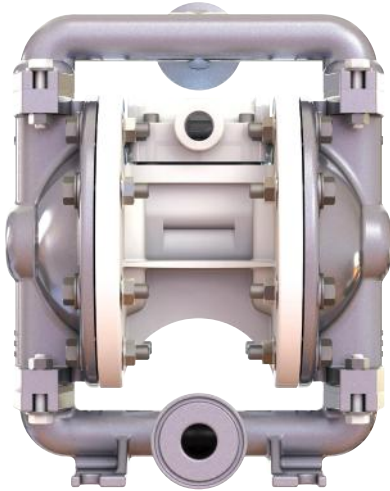

Technical Specifications

Max Flow 11 GPM (41,6 LPM)
Max Air Supply or Liquid Pressure ... 100 psig (6,9 bar)
Max Particle Size (Dia.) 1/16" (1,6 mm)
Suction Lift 12' Dry / 22' Wet (3,6 m / 6,7 m)
Temperature Range ... -35° F (-37° C) to 220° F (104° C)
Elastomers PTFE
Center Block Polypropylene
Wetted Section SS316

Port Configuration Center Horizontal
Intake / Discharge Connection 1" Tri-Clamp®
Air Inlet / Exhaust 3/8" NPT
Noise Level 87 db (A)
Shipping Weight 17 lbs (7,7 kg)
Wet End Kit Part Number 200-010
Air Valve Kit Part Number 200-001

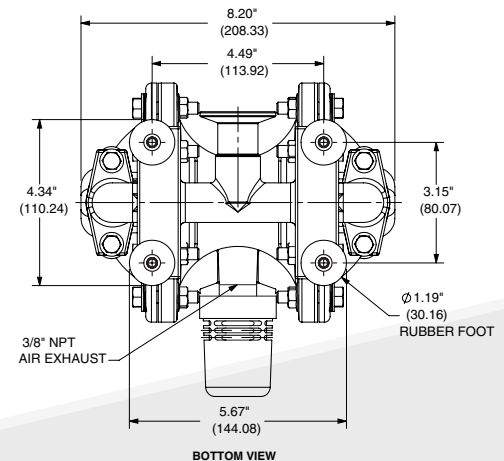
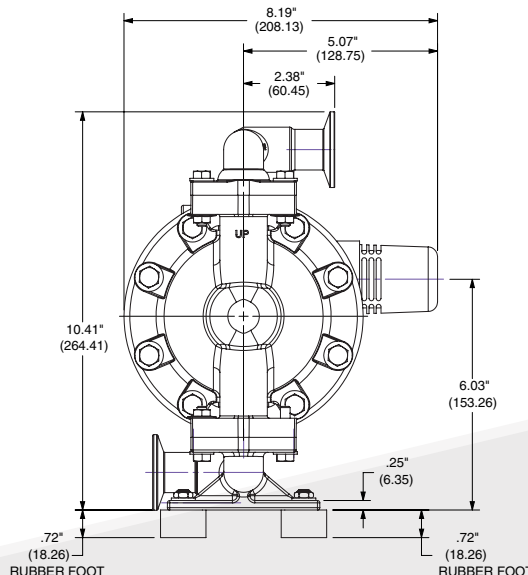
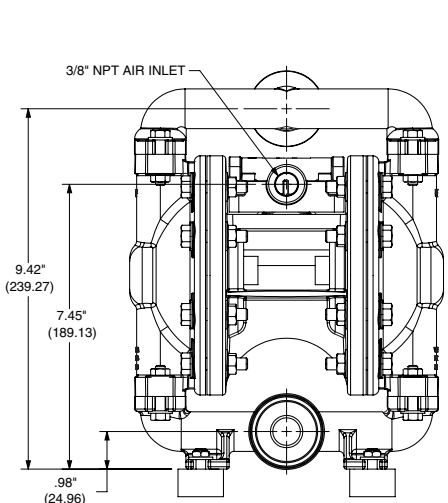

STANDARD
Pumps, Inc.
www.standardpump.com