

SANITARY PUMPS

SPSN20NPS – 2"

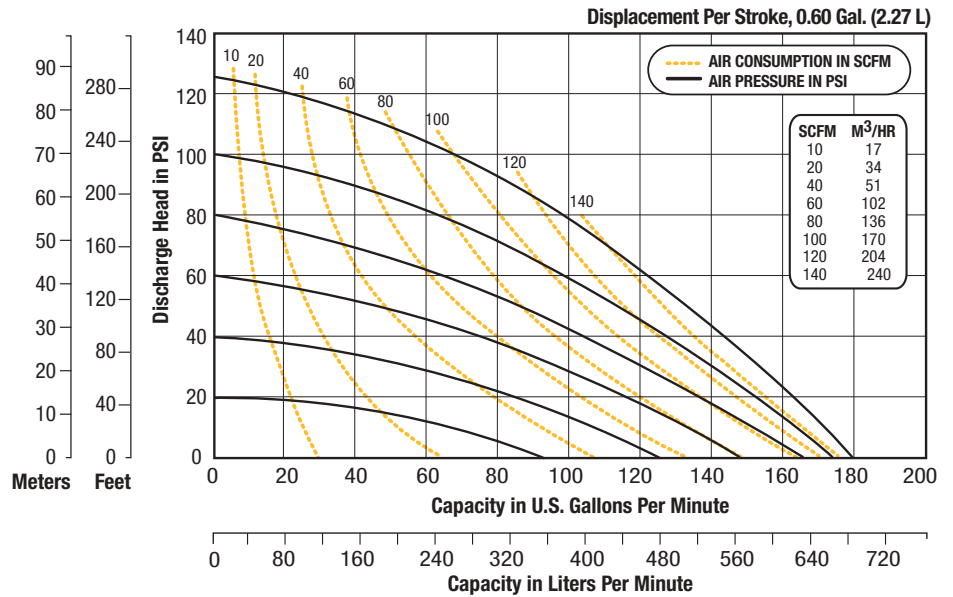

Technical Specifications

Max Flow 179 GPM (677 LPM)
Max Air Supply or Liquid Pressure 100 psig (6,9 bar)
Max Particle Size (Dia.) 5/8" (15,9 mm)
Suction Lift 15' Dry / 32' Wet (4,6 m / 9,8 m)
Temperature Range ... -40° F (-40° C) to 275° F (134° C)
Elastomers Santoprene
Center Block Nickel Plated Aluminum
Wetted Section SS316L-Polished to 32 Ra

Port Configuration Center Horizontal
Intake / Discharge Connection 2" Tri-Clamp®
Air Inlet / Exhaust 1/2" NPT / 1" NPT
Noise Level 98 db (A)
Shipping Weight 125 lbs (56.7 kg)
Wet End Kit Part Number 200-160
Air Valve Kit Part Number 200-004

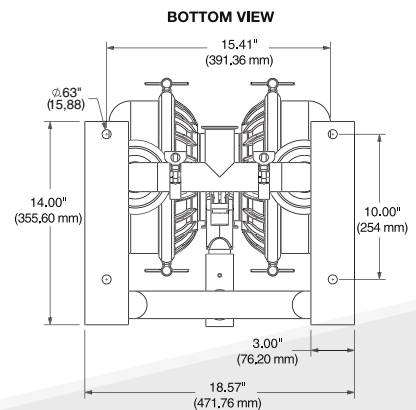
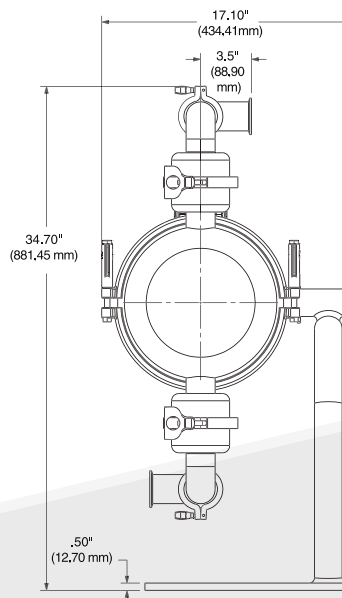
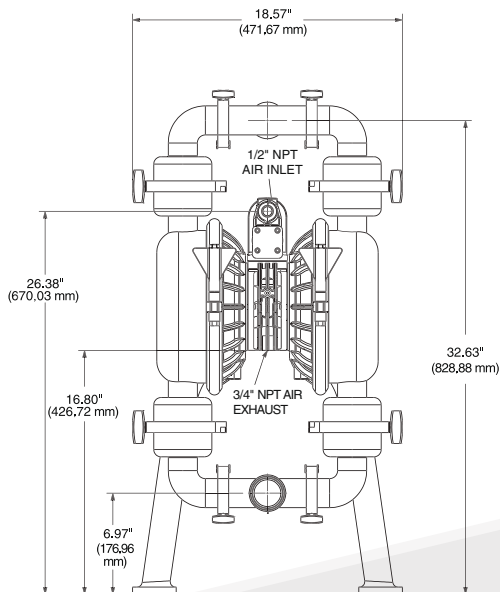

STANDARD
Pumps Inc.
www.standardpump.com