

2" 3-A Certified
with Metallic Center Section

SP3A20NPT

3-A Sanitary Pump
• Stainless Steel

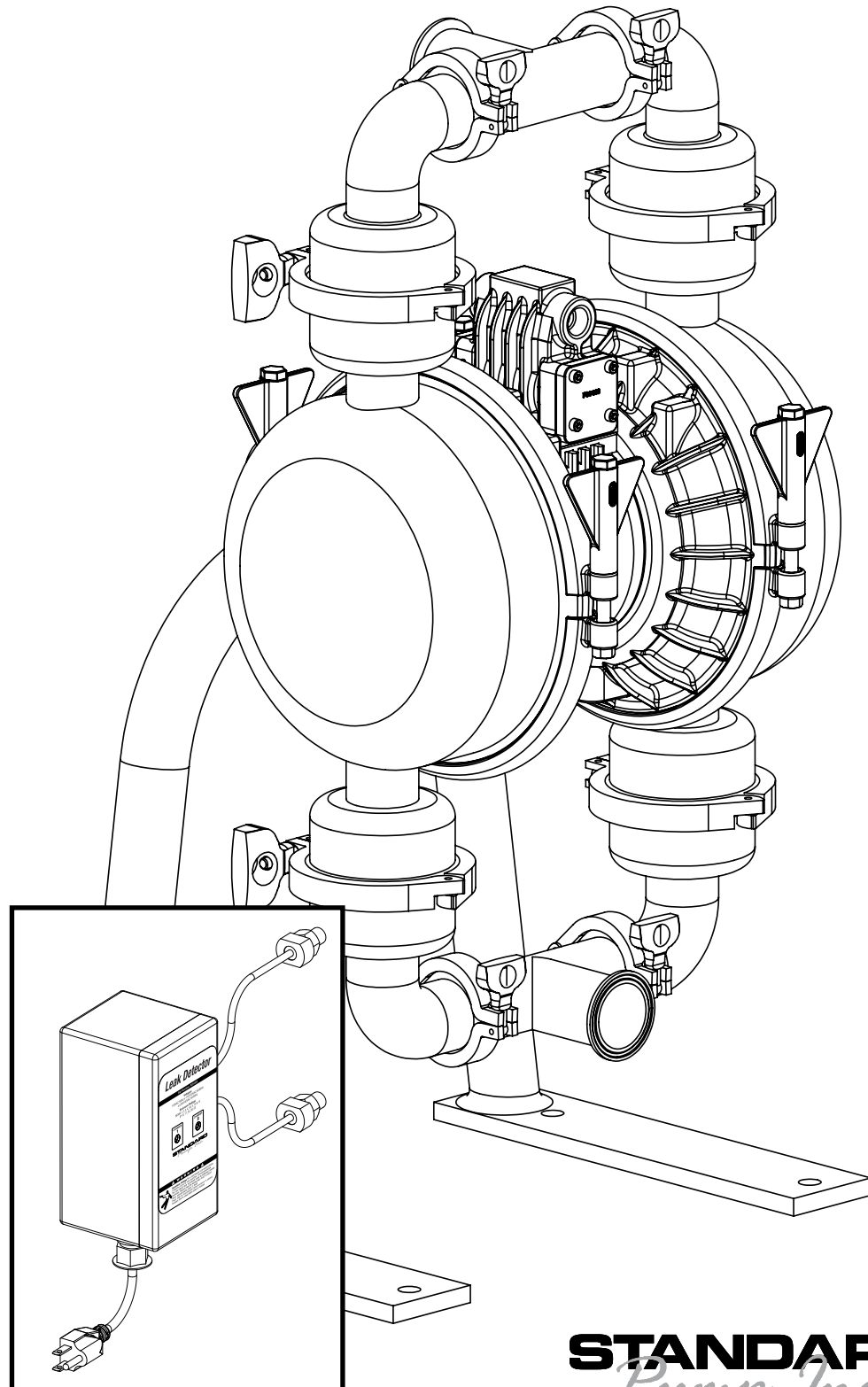

STANDARD
Pump, Inc.

1: PUMP SPECS

2: INSTAL & OP

3: EXP VIEW

4: CERTIFICATES

Safety Information

IMPORTANT



Read the safety warnings and instructions in this manual before pump installation and start-up. Failure to comply with the recommendations stated in this manual could damage the pump and void factory warranty.



When the pump is used for materials that tend to settle out or solidify, the pump should be flushed after each use to prevent damage. In freezing temperatures the pump should be completely drained between uses.

CAUTION



Before pump operation, inspect all fasteners for loosening caused by gasket creep. Retighten loose fasteners to prevent leakage. Follow recommended torques stated in this manual.



Nonmetallic pumps and plastic components are not UV stabilized. Ultraviolet radiation can damage these parts and negatively affect material properties. Do not expose to UV light for extended periods of time.



WARNING

Pump not designed, tested or certified to be powered by compressed natural gas. Powering the pump with natural gas will void the warranty.

WARNING



When used for toxic or aggressive fluids, the pump should always be flushed clean prior to disassembly.



Before maintenance or repair, shut off the compressed air line, bleed the pressure, and disconnect the air line from the pump. Be certain that approved eye protection and protective clothing are worn at all times. Failure to follow these recommendations may result in serious injury or death.



Airborne particles and loud noise hazards. Wear eye and ear protection.



In the event of diaphragm rupture, pumped material may enter the air end of the pump, and be discharged into the atmosphere. If pumping a product that is hazardous or toxic, the air exhaust must be piped to an appropriate area for safe containment.



Take action to prevent static sparking. Fire or explosion can result, especially when handling flammable liquids. The pump, piping, valves, containers and other miscellaneous equipment must be properly grounded.



This pump is pressurized internally with air pressure during operation. Make certain that all fasteners are in good condition and are reinstalled properly during reassembly.



Use safe practices when lifting

Table of Contents

SECTION 1: PUMP SPECIFICATIONS.....1

- Performance
- Materials
- Dimensional Drawings

SECTION 2: INSTALLATION & OPERATION.....3

- Principle of Pump Operation
- Typical Installation Guide
- Troubleshooting

SECTION 3: EXPLODED VIEW.....7

- Composite Drawings
- Parts List
- Materials Code

SECTION 4: CERTIFICATES9

- EC Declaration of Conformity - Machinery
- 3-A Certificate

1: PUMP SPECS

2: INSTAL & OP

3: EXP VIEW

4: CERTIFICATES

Performance

SP3A20NPT - 2" 3-A Sanitary Pump – Metallic Center

Flow Rate

Adjustable to 0-147 gpm (556 lpm)

Port Size

Suction 2" TRI-CLAMP

Discharge 2" TRI-CLAMP

Air Inlet 1/2" NPT

Air Exhaust 1" NPT

Suction Lift

Dry9' (2.7 m)

Wet27' (8.2 m)

Max Solid Size (Diameter)

..... 5/8" (15.8 mm)

Max Noise Level 98 dB(A)

Shipping Weights

Stainless 125 lbs (56.7 kg)

1: PUMP SPECS

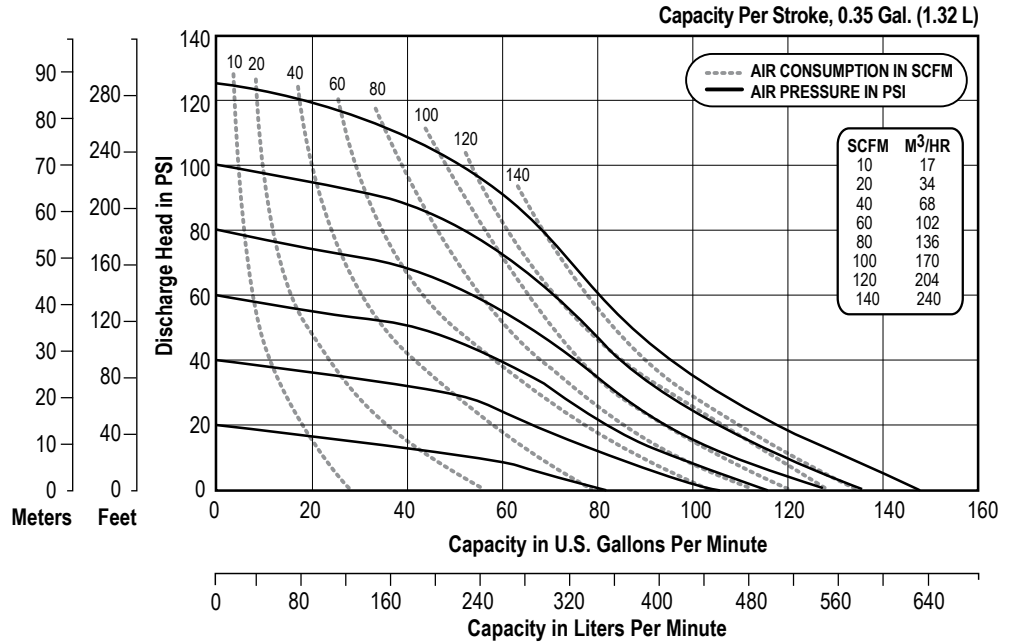

NOTE: Performance based on the following: elastomeric fitted pump, flooded suction, water at ambient conditions. The use of other materials and varying hydraulic conditions may result in deviations in excess of 5%.

Materials

Material Profile:

CAUTION! Operating temperature limitations are as follows:

Virgin PTFE: (PFA/TFE) Chemically inert, virtually impervious. Very few chemicals are known to chemically react with PTFE; molten alkali metals, turbulent liquid or gaseous fluorine and a few fluoro-chemicals such as chlorine trifluoride or oxygen difluoride which readily liberate free fluorine at elevated temperatures.

Maximum and Minimum Temperatures are the limits for which these materials can be operated. Temperatures coupled with pressure affect the longevity of diaphragm pump components. Maximum life should not be expected at the extreme limits of the temperature ranges.

Metals:

Stainless Steel: Equal to or exceeding ASTM specification A743 CF-8M for corrosion resistant iron chromium, iron chromium nickel and nickel based alloy castings for general applications. Commonly referred to as 316 Stainless Steel in the pump industry.

Operating Temperatures:

Max.	Min.
220°F	-35°F
104°C	-37°C

Dimensional Drawings

SP3A20NPT

Dimensions in inches (mm dimensions in brackets)

The dimensions on this drawing are for reference only. A certified drawing can be requested if physical dimensions are needed.

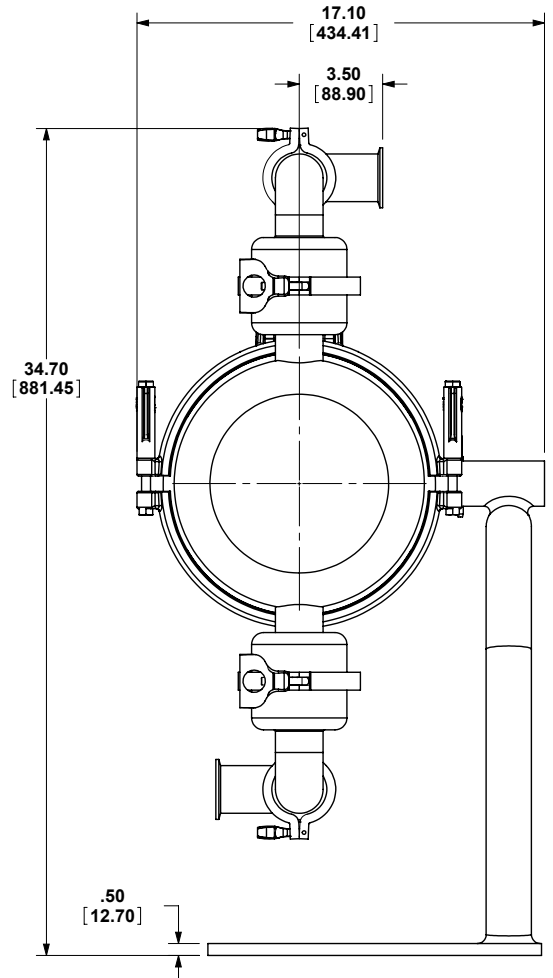
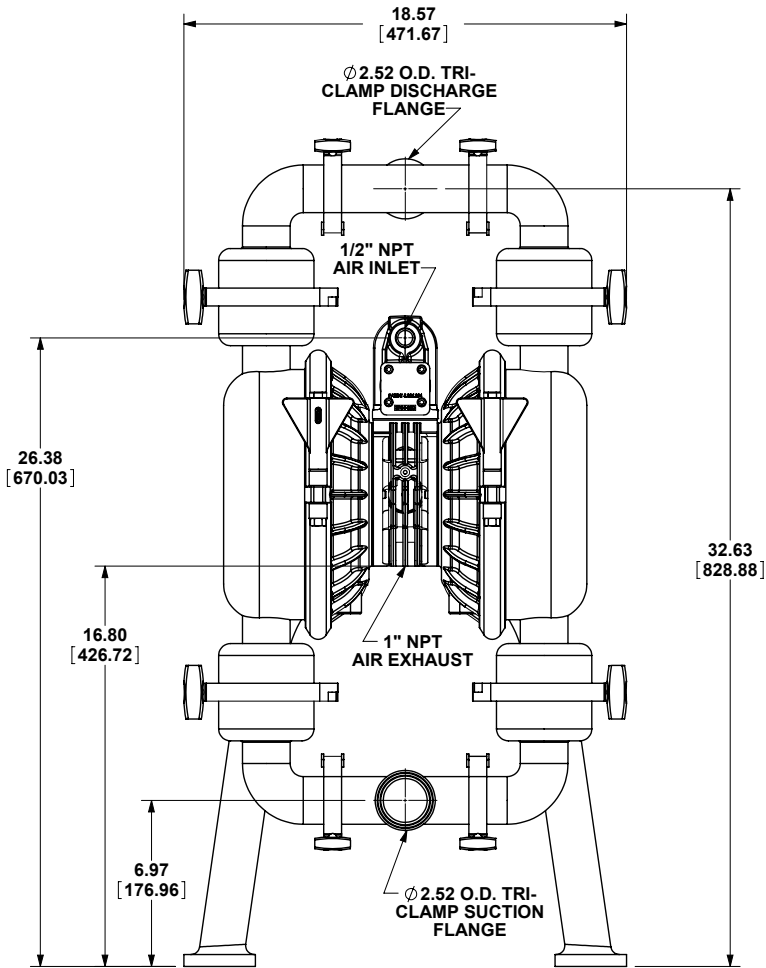

1: PUMP SPECS

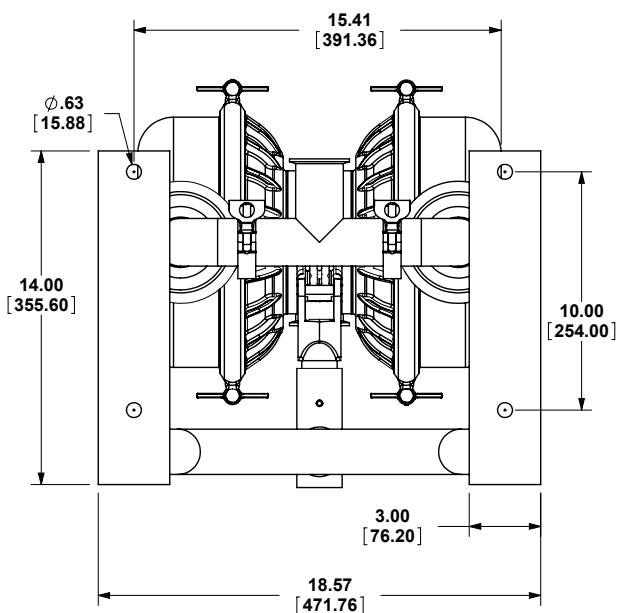

Principle of Pump Operation

Air-Operated Double Diaphragm (AODD) pumps are powered by compressed air or nitrogen.

The main directional (air) control valve ① distributes compressed air to an air chamber, exerting uniform pressure over the inner surface of the diaphragm ②. At the same time, the exhausting air ③ from behind the opposite diaphragm is directed through the air valve assembly(s) to an exhaust port ④.

As inner chamber pressure (P1) exceeds liquid chamber pressure (P2), the rod ⑤ connected diaphragms shift together creating discharge on one side and suction on the opposite side. The discharged and primed liquid's directions are controlled by the check valves (ball or flap) ⑥ orientation.

The pump primes as a result of the suction stroke. The suction stroke lowers the chamber pressure (P3) increasing the chamber volume. This results in a pressure differential necessary for atmospheric pressure (P4) to push the fluid through the suction piping and across the suction side check valve and into the outer fluid chamber ⑦.

Suction (side) stroking also initiates the reciprocating (shifting, stroking or cycling) action of the pump. The suction diaphragm's movement is mechanically pulled through its stroke. The diaphragm's inner plate makes contact with an actuator plunger aligned to shift the pilot signaling valve. Once actuated, the pilot valve sends a pressure signal to the opposite end of the main directional air valve, redirecting the compressed air to the opposite inner chamber.

SUBMERGED ILLUSTRATION

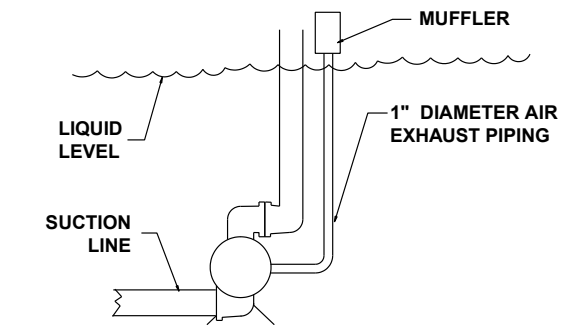

Pump can be submerged if the pump materials of construction are compatible with the liquid being pumped. The air exhaust must be piped above the liquid level. When the pumped product source is at a higher level than the pump (flooded suction condition), pipe the exhaust higher than the product source to prevent siphoning spills.

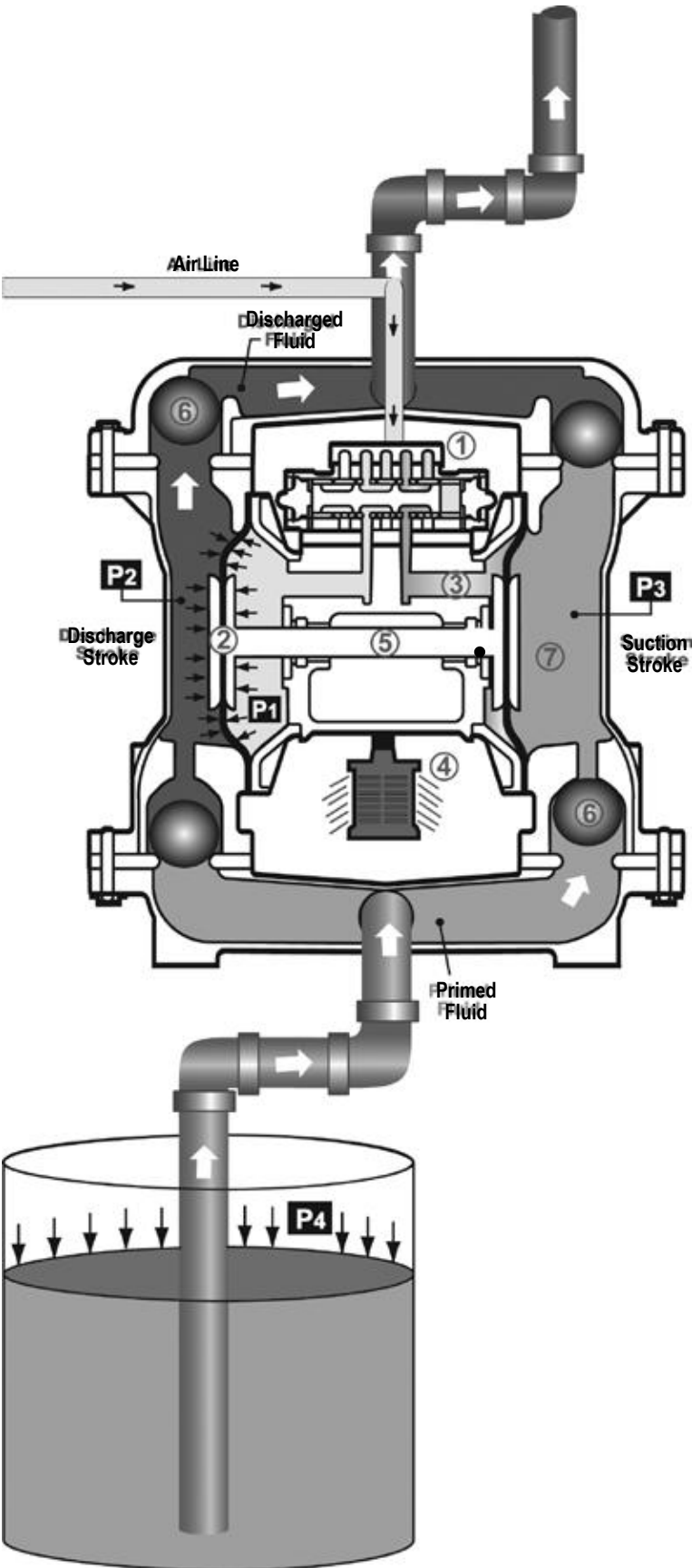

2: INSTAL & OP

Recommended Installation Guide

Available Accessories:

1. Surge Suppressor
2. Filter/Regulator
3. Air Dryer

Note: Surge Suppressor and Piping must be supported after the flexible connection.

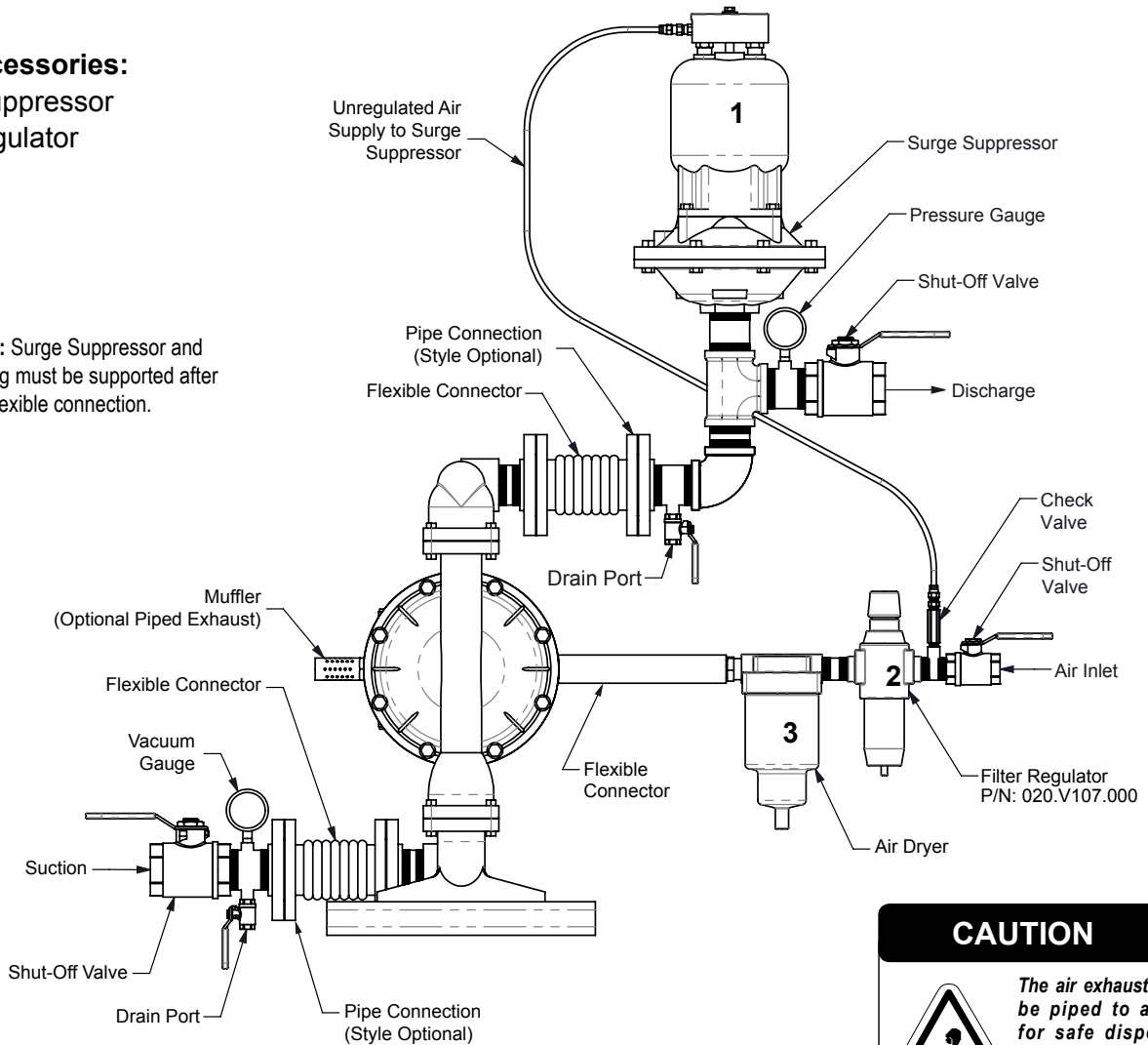

CAUTION

The air exhaust should be piped to an area for safe disposition of the product being pumped, in the event of a diaphragm failure.

Installation And Start-Up

Locate the pump as close to the product being pumped as possible. Keep the suction line length and number of fittings to a minimum. Do not reduce the suction line diameter.

Air Supply

Connect the pump air inlet to an air supply with sufficient capacity and pressure to achieve desired performance. A pressure regulating valve should be installed to insure air supply pressure does not exceed recommended limits.

Air Valve Lubrication

The air distribution system is designed to operate **WITHOUT** lubrication. This is the standard mode of operation. If lubrication is desired, install an air line lubricator set to deliver one drop of SAE 10 non-detergent oil for every 20 SCFM (9.4 liters/sec.) of air the pump consumes. Consult the Performance Curve to determine air consumption.

Air Line Moisture

Water in the compressed air supply may cause icing or freezing of the exhaust air, causing the pump to cycle erratically or stop operating. Water in the air supply can be reduced by using a point-of-use air dryer.

Air Inlet And Priming

To start the pump, slightly open the air shut-off valve. After the pump primes, the air valve can be opened to increase air flow as desired. If opening the valve increases cycling rate, but does not increase the rate of flow, cavitation has occurred. The valve should be closed slightly to obtain the most efficient air flow to pump flow ratio.

2: INSTAL & OP

Troubleshooting Guide

Symptom:	Potential Cause(s):	Recommendation(s):
Pump Cycles Once	Deadhead (system pressure meets or exceeds air supply pressure).	Increase the inlet air pressure to the pump. Pump is designed for 1:1 pressure ratio at zero flow. (Does not apply to high pressure 2:1 units).
	Air valve or intermediate gaskets installed incorrectly.	Install gaskets with holes properly aligned.
	Bent or missing actuator plunger.	Remove pilot valve and inspect actuator plungers.
Pump Will Not Operate / Cycle	Pump is over lubricated.	Set lubricator on lowest possible setting or remove. Units are designed for lube free operation.
	Lack of air (line size, PSI, CFM).	Check the air line size and length, compressor capacity (HP vs. cfm required).
	Check air distribution system.	Disassemble and inspect main air distribution valve, pilot valve and pilot valve actuators.
	Discharge line is blocked or clogged manifolds.	Check for inadvertently closed discharge line valves. Clean discharge manifolds/piping.
	Deadhead (system pressure meets or exceeds air supply pressure).	Increase the inlet air pressure to the pump. Pump is designed for 1:1 pressure ratio at zero flow. (Does not apply to high pressure 2:1 units).
	Blocked air exhaust muffler.	Remove muffler screen, clean or de-ice, and re-install.
	Pumped fluid in air exhaust muffler.	Disassemble pump chambers. Inspect for diaphragm rupture or loose diaphragm plate assembly.
	Pump chamber is blocked.	Disassemble and inspect wetted chambers. Remove or flush any obstructions.
Pump Cycles and Will Not Prime or No Flow	Cavitation on suction side.	Check suction condition (move pump closer to product).
	Check valve obstructed. Valve ball(s) not seating properly or sticking.	Disassemble the wet end of the pump and manually dislodge obstruction in the check valve pocket. Clean out around valve ball cage and valve seat area. Replace valve ball or valve seat if damaged. Use heavier valve ball material.
	Valve ball(s) missing (pushed into chamber or manifold).	Worn valve ball or valve seat. Worn fingers in valve ball cage (replace part). Check Chemical Resistance Guide for compatibility.
	Valve ball(s)/seat(s) damaged or attacked by product.	Check Chemical Resistance Guide for compatibility.
	Check valve and/or seat is worn or needs adjusting.	Inspect check valves and seats for wear and proper setting. Replace if necessary.
	Suction line is blocked.	Remove or flush obstruction. Check and clear all suction screens or strainers.
	Excessive suction lift.	For lifts exceeding 20' of liquid, filling the chambers with liquid will prime the pump in most cases.
	Suction side air leakage or air in product.	Visually inspect all suction-side gaskets and pipe connections.
	Pumped fluid in air exhaust muffler.	Disassemble pump chambers. Inspect for diaphragm rupture or loose diaphragm plate assembly.
	Pump Cycles Running Sluggish/Stalling, Flow Unsatisfactory	Over lubrication.
Icing.		Remove muffler screen, de-ice, and re-install. Install a point of use air drier.
Clogged manifolds.		Clean manifolds to allow proper air flow
Deadhead (system pressure meets or exceeds air supply pressure).		Increase the inlet air pressure to the pump. Pump is designed for 1:1 pressure ratio at zero flow. (Does not apply to high pressure 2:1 units).
Cavitation on suction side.		Check suction (move pump closer to product).
Lack of air (line size, PSI, CFM).		Check the air line size, length, compressor capacity.
Excessive suction lift.		For lifts exceeding 20' of liquid, filling the chambers with liquid will prime the pump in most cases.
Air supply pressure or volume exceeds system hd.		Decrease inlet air (press. and vol.) to the pump. Pump is cavitating the fluid by fast cycling.
Undersized suction line.		Meet or exceed pump connections.
Restrictive or undersized air line.		Install a larger air line and connection.
Suction side air leakage or air in product.		Visually inspect all suction-side gaskets and pipe connections.
Suction line is blocked.		Remove or flush obstruction. Check and clear all suction screens or strainers.
Pumped fluid in air exhaust muffler.		Disassemble pump chambers. Inspect for diaphragm rupture or loose diaphragm plate assembly.
Check valve obstructed.		Disassemble the wet end of the pump and manually dislodge obstruction in the check valve pocket.
Check valve and/or seat is worn or needs adjusting.		Inspect check valves and seats for wear and proper setting. Replace if necessary.
Product Leaking Through Exhaust	Diaphragm failure, or diaphragm plates loose.	Replace diaphragms, check for damage and ensure diaphragm plates are tight.
	Diaphragm stretched around center hole or bolt holes.	Check for excessive inlet pressure or air pressure. Consult Chemical Resistance Chart for compatibility with products, cleaners, temperature limitations and lubrication.
Premature Diaphragm Failure	Cavitation.	Enlarge pipe diameter on suction side of pump.
	Excessive flooded suction pressure.	Move pump closer to product. Raise pump/place pump on top of tank to reduce inlet pressure. Install Back pressure device (Tech bulletin 41r). Add accumulation tank or pulsation dampener.
	Misapplication (chemical/physical incompatibility).	Consult Chemical Resistance Chart for compatibility with products, cleaners, temperature limitations and lubrication.
	Incorrect diaphragm plates or plates on backwards, installed incorrectly or worn.	Check Operating Manual to check for correct part and installation. Ensure outer plates have not been worn to a sharp edge.
Unbalanced Cycling	Excessive suction lift.	For lifts exceeding 20' of liquid, filling the chambers with liquid will prime the pump in most cases.
	Undersized suction line.	Meet or exceed pump connections.
	Pumped fluid in air exhaust muffler.	Disassemble pump chambers. Inspect for diaphragm rupture or loose diaphragm plate assembly.
	Suction side air leakage or air in product.	Visually inspect all suction-side gaskets and pipe connections.
	Check valve obstructed.	Disassemble the wet end of the pump and manually dislodge obstruction in the check valve pocket.
	Check valve and/or seat is worn or needs adjusting.	Inspect check valves and seats for wear and proper setting. Replace if necessary.
Entrained air or vapor lock in chamber(s).	Purge chambers through tapped chamber vent plugs.	

For additional troubleshooting tips contact After Sales Support at service.warrenrupp@idexcorp.com or 419-524-8388

Pump Inspection and Cleaning

The SP3A20NPT sanitary pump can be cleaned using several techniques. However, it is important to follow guidelines set by the IAMFES, the USPHS, and the DIC and/or internal rules for inspection, cleaning and sanitization.

If the pump is to be steam cleaned, disconnect the suction line from the pump. Connect the steam line to the pump inlet. Maintain the flow of steam through the pump for at least five minutes after the temperature at the outlet has reached 200°F (94°C).

Hot water may also be used. Pump water that is maintained at minimum of 170°F (77°C) through the pump for at least five minutes. Please note that the maximum cleaning temperature of the pump is 220° (104°C).

Chemical cleaning may also be used in sanitizing the pump. Be sure to consult your distributor or the manufacturer to verify that the elastomer(s) used in the pump are compatible with the chemicals being used in the cleaning process.

Composite Repair Parts Drawing

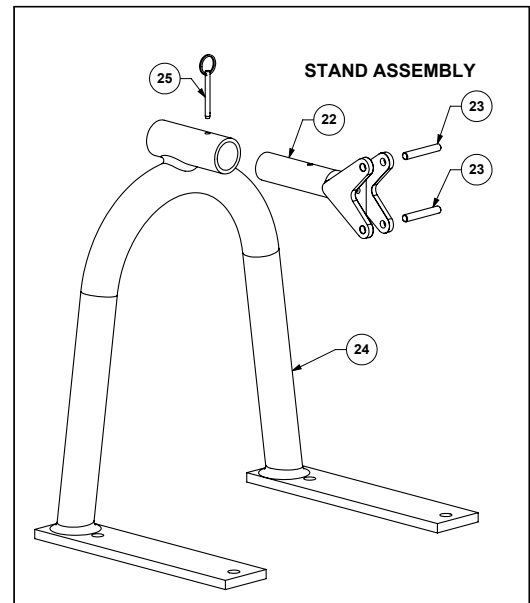
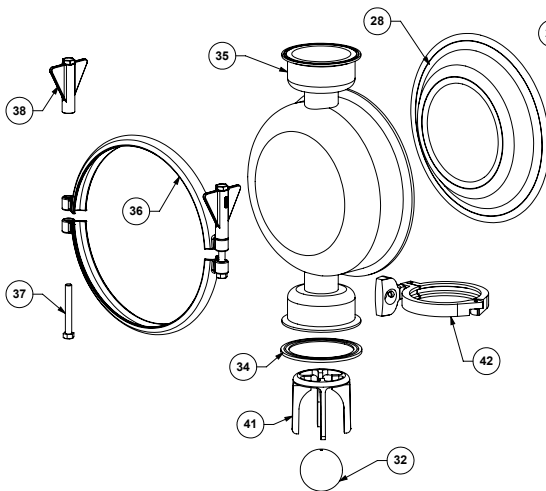
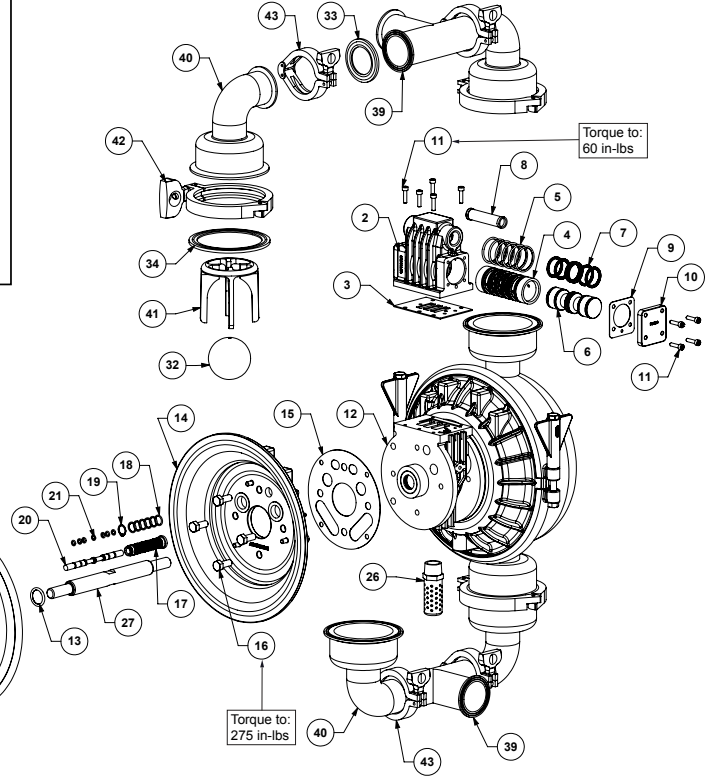
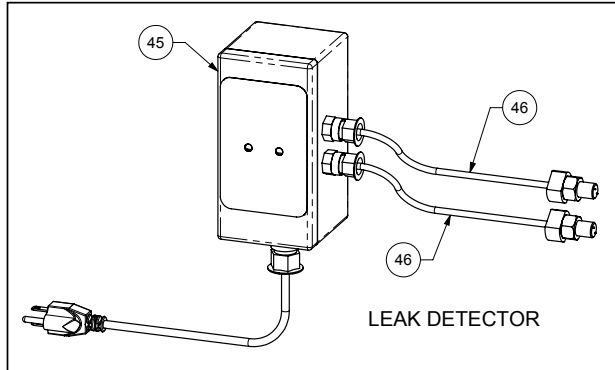

3: EXP VIEW

Composite Repair Parts List

Air Valve Assembly			
Item #	Qty.	Description	Part Number
			Nickle Plated
1	1	Valve Body (Includes items 2-11)	200-201
2	1	Valve Body	200-206
3	1	Valve Body Gasket	200-277
4	1	Valve Sleeve Assembly	200-236
5	6	O-Ring	200-224
6	1	Valve Spool Assembly (includes items 7)	200-238
7	6	Glyde Ring Assembly	200-307
8	1	Air Valve Screen	200-279
9	2	End Cap Gasket	200-278
10	2	End Cap	200-332
11	13	Mounting Screws	200-324
Center Section Assembly			
Item #	Qty.	Description	Part Number
			Nickle Plated
12	1	Center Block Assembly (includes item 13)	200-280
13	2	Main Shaft O-Ring	200-282
14	2	Air Chamber	200-210
15	2	Air Chamber Gasket	200-214
16	8	Bolt	200-327
17	1	Pilot Sleeve Assembly (includes item 18)	200-232
18	6	O-Ring	200-223
19	1	Retaining Ring	200-227
20	1	Pilot Spool Assembly (includes item 21)	200-239
21	7	O-Ring	200-221
22	1	Stand Attachment	200-465
23	2	Stand Attachment Pin	200-291
24	1	Stand	200-328
25	1	Stand Locking Pin	200-289
26	1	Muffler	200-218
Diaphragm Assembly / Elastomers			
Item #	Qty.	Description	Part Number
27	1	Main Shaft	200-273
28	2	Diaphragm	200-396
32	4	Check Ball	200-399
33	4	Manifold Tee Seal	200-411
34	4	Manifold Elbow Seal	200-414
Wet End Assembly			
Item #	Qty.	Description	Part Number
35	2	Water Chamber	200-246
36	4	Large Clamp Half	200-357
37	4	Bolt	200-358
38	4	Wing Nut	200-269
39	2	Manifold Tee	200-248
40	4	Manifold Elbow	200-247
41	4	Ball Cage	200-463
42	4	Manifold Elbow Clamp	200-409
43	4	Manifold Tee Clamp	200-412
45	1	Leak Detector	200-006
46	2	Leak Detector Probe	200-007

3: EXP VIEW

DECLARATION OF CONFORMITY

DECLARATION DE CONFORMITE • DECLARACION DE CONFORMIDAD • ERKLÄRUNG BEZÜGLICH EINHALTUNG DER VORSCHRIFTEN
DICHIARAZIONE DI CONFORMITÀ • CONFORMITEITSVERKLARING • DEKLARATION OM ÖVERENSSTÄMMELSE
EF-OVERENSSTEMMELSESERKLÆRING • VAATIMUSTENMUKAISUUSVAKUUTUS • SAMSVARSERKLÄRING
DECLARAÇÃO DE CONFORMIDADE

MANUFACTURED BY:

FABRIQUE PAR:
FABRICADA POR:
HERGESTELLT VON:
FABBRICATO DA:
VERVAARDIGD DOOR:
TILLVERKAD AV:
FABRIKANT:
VALMISTAJA:
PRODUSENT:
FABRICANTE:

STANDARD PUMP, INC.®
1610 Satellite Blvd., Suite D
Duluth, GA 30097
USA
Tel: 770-307-1003

STANDARD
Pump, Inc.

**PUMP MODEL SERIES: SPFP05, SPFP10, SPFP15, SPFP20, SPFP30,
SPSN15, SPSN20, SP3A15, SP3A20**

This product complies with the following European Community Directives:

Ce produit est conforme aux directives de la Communauté européenne suivantes:
Este producto cumple con las siguientes Directrices de la Comunidad Europea:
Dieses produkt erfüllt die folgenden Vorschriften der Europäischen Gemeinschaft:
Questo prodotto è conforme alle seguenti direttive CEE:
Dir produkt voldoet aan de volgende EG-richtlijnen:
Denna produkt överensstämmer med följande EU direktiv:
Standard Pump, Inc., erklærer herved som fabrikant, at ovennævnte produkt er i overensstemmelse med bestemmelserne i Direktive:
Tämä tuote täyttää seuraavien EC Direktiivien vaatimukset:
Dette produkt oppfylder kravene til følgende EC Direktiver:
Este produto está de acordo com as seguintes Directivas comunitárias:

2006/42/EC
on Machinery, according
to Annex VIII

This product has used the following harmonized standards to verify conformance:

Ce matériel est fabriqué selon les normes harmonisées suivantes, afin d' en garantir la conformité:
Este producto cumple con las siguientes directrices de la comunidad europea:
Dieses produkt ist nach folgenden harmonisierten standards gefertigt worden, die übereinstimmung wird bestätigt:
Questo prodotto ha utilizzato i seguenti standards per verificare la conformità:
De volgende geharmoniseerde normen werden gehanteerd om de conformiteit van dit produkt te garanderen:
För denna produkt har följande harmoniserande standarder använts för att bekräfta överensstämmelse:
Harmoniserede standarder, der er benyttet:
Tässä tuotteessa on sovellettu seuraavia yhdenmukaistettuja standardeja:
Dette produkt er produsert i overensstemmelse med følgende harmoniserte standarder:
Este produto utilizou os seguintes padrões harmonizados para varificar conformidade:

EN809:1998+
A1:2009

AUTHORIZED/ APPROVED BY:

Approuve par:
Aprobado por:
Genehmigt von:
approvato da:
Goedgekeurd door:
Underskrift:
Valtuutettuna:
Bemyndiget av:
Autorizado Por:

Chris Murphy
Chris Murphy
Director of Operations

DATE: July 20, 2012

FECHA:
DATUM:
DATA:
DATO:
PÄIVÄYS:

CE

ISSUE DATE: November 06, 2012

CERTIFICATE AUTHORIZATION NUMBER: 1679



THIS IS TO CERTIFY THAT

Standard Pumps, Inc.

1610 Satellite Blvd., Suite D, Duluth, GA 30097

is hereby authorized to continue to apply the
3-A Symbol to the models of equipment, conforming to 3-A Sanitary Standards for:

Number 44-03
44-03 (Diaphragm Pumps)

set forth below

Clean-in-Place Models: SP3A15NPT, SP3A20NPT.

VALID THROUGH: **December 31, 2016**

Timothy R. Rugh
Executive Director
3-A Sanitary Standards, Inc.

The issuance of this authorization for the use of the 3-A Symbol is based upon the voluntary authorization, by the applicant for it, that the equipment listed above complies fully with the 3-A Sanitary Standards designated. Legal responsibility for compliance is solely that of the holder of this Certificate of Authorization, and 3-A Sanitary Standards, Inc. does not warrant that the holder of an authorization at all times complies with the provisions of the said 3-A Sanitary Standard. This in no way affects the responsibility of 3-A Sanitary Standards, Inc. to take appropriate action in such cases in which evidence of nonconformance had been established.

NEXT TPV INSPECTION/REPORT DUE: **October 2017**