

Read all the following information and instructions prior to installing and operating the equipment.  
Failure to comply with these instructions could result in bodily injury or property damage.



## TABLE OF CONTENTS

Introduction .....	1
Receiving, Handling, and Inspection .....	2
Storage .....	2
Operating Modes .....	2
Continuous Backwash .....	2
Automatic Backwash (Timed Cycle) .....	2
Valves .....	2
Valve Selection .....	2
Backwash/Blow-Down/Drain Valve .....	3
Electric Actuators .....	3
Pneumatic Actuators.....	3
Differential Pressure Switches .....	4
Switch Description.....	4
Mounting, Piping and Wiring .....	4
Adjustment.....	4
Control Panel.....	5
Description .....	5
Cycle Time Sequence.....	5
Standard Features .....	5
Operating Modes.....	6
Changing Backwash Timer Settings.....	6
SmartWire-DT Error Messages.....	7
System Error Messages.....	7
Electrical Schematic Diagram .....	8
Typical Installation .....	9

## INTRODUCTION

An automatic, self-cleaning strainer requires a control system to provide flexibility and optimize performance of the straining operation. A number of standard options are available or specify a custom designed control system.

This manual will define the installation requirement, operation, and maintenance of the Eaton control system.

## RECEIVING, HANDLING AND INSPECTION

The control panel, motor and accessories have been packed in a separate container but shipped with the strainer. This provides protection from damage during transit and also provides for ease of storage if the controls are not installed immediately. When first received the following must be done:

1. Unpack and inspect for damage.
2. Report any damage to carrier immediately.
3. If controls are not installed at this time, refer to Storage Instructions.

## STORAGE INSTRUCTIONS

Repack all components in the original carton and reuse all protective packaging. Store all components in an indoor, clean, and dry environment. Protect from temperature extremes. Mark cartons to protect from handling abuse.

## STRAINER MODE OF OPERATION CONTINUOUS BACKWASH

This is the most effective way to keep the strainer element “clean” and have the least pressure loss. Continuous element washing can be accomplished with a minimum of control devices. However, it offers no flexibility of operation when there are significant changes in flow volume or solids content of the fluid.

The “drain” line requires a blow-down/drain valve which may be manually operated. Normal valve position is CLOSED.

The backwash line requires a backwash valve which may be manually operated on the backwash line. Normal valve position is FULL OPEN.

The backwash motor requires a motor starter. Furnish with overload protection and fused disconnect.

## STRAINER MODE OF OPERATION AUTOMATIC BACKWASH (TIMED CYCLE)

The preferred mode of operation for a self-cleaning strainer is one where the control system will permit both intermittent and continuous backwash as required by operating conditions.

The “drain” line requires a blow-down/drain valve which may be manually operated. Normal valve position is CLOSED.

The backwash line requires a backwash valve, either electrically or pneumatically operated on the backwash line. This valve should operate only in the FULL OPEN or FULL CLOSED position.

A fully adjustable differential pressure switch is furnished to detect the increase of pressure across the strainer. It will activate a backwash cycle independent of the time-controlled sequence. NOTE: Set switch at 2psi over the observed clean pressure drop.

Eaton provides a control panel, containing all necessary relays, timers, lights, switches, etc. This will initiate and monitor the intermittent backwash cycles.

## VALVE SELECTION

Several important factors to consider when selecting the necessary valves.

Valve Type: Gate, plug, and butterfly valves can be used. However, ball valves provide the most advantages. Ball valves, when “Full Open” provide a uniform and straight flow path minimizing pressure loss. Since only 90° rotation of the stem is required to go from “Fully Closed” to “Fully Open” motorized operators are easily adapted and provide short cycle times.

Valve Material: Iron, bronze, steel, and stainless steel are the most common. Select valve and trim material that will not corrode or react with the process fluid or the environment.

Pressure Rating: Select the valve class with a pressure rating equal to or greater than the system design pressure.

Connection: Select a valve with end connections (flanged, threaded, etc.) that will provide ease of maintenance and trouble-free service.

**STRAINER MODE OF OPERATION  
CONTINUOUS BACKWASH**

Several valves are required for various applications. Ball valves of the proper size, end connection, material, and pressure rating are recommended for these services.

Manually operated valves are best suited for “blow-down” and “chamber drain” service. They may also be used for continuous backwash service.

For timed cycle backwash, the valve should be operated by an electric or pneumatic valve actuator.

Larger size strainers require both a “blow-down drain” and a “chamber drain” for the body.

The table below lists the service functions and sizes of valves for standard strainers.

**Model 596**

Size	Backwash	Chamber Drain
2", 3", 4"	1"	$\frac{3}{4}$ "
6", 8"	1 $\frac{1}{2}$ "	$\frac{3}{4}$ "

**Model 2596**

Size	Backwash	Chamber Drain
10" to 16"	1"	$\frac{3}{4}$ "
18" to 30"	3"	2"
36"	6"	3"

**ELECTRIC ACTUATORS**

The required actuator size depends on the backwash valve torque requirements. The motors are “shaded pole” or “split capacitor” type.

115 Vac, 10 Hz actuator motors are standard, other voltages are available.

The standard actuators require simple wiring from the control panel to the actuator (see Fig 2).

**PNEUMATIC ACTUATORS**

A double-acting piston design that uses a clean air supply of 40-125 psi pressure, powers the actuator properly.

Using an electric signal, a solenoid pilot valve controls the air supply to the actuator.

Most actuators have pipe thread connections (NPT) located so that the solenoid valves may be mounted with minimal tubing runs.

Customer must run wiring and conduit from the control panel terminals to the solenoid valve (see Fig 2).

Piping (or tubing) is required from the solenoid valve to the air supply system (this is customer scope of supply).

The solenoid pilot valve must be piped to the actuator so that the backwash valve will close when there is no electric power to the solenoid.

**SAMPLE OPERATION USING 3-  
WAY SOLENOID VALVE**

Power On: Air supply from the pilot valve to actuator is “Open” but vent is “Closed.”

Power Off: Air supply to actuator is “Closed.” Vent connection is “Open.”

**DIFFERENTIAL PRESSURE SWITCHES**  
**SWITCH DESCRIPTION**  
**(SINGLE OR DUAL ELEMENT)**

A diaphragm type differential control with single switch is standard. It initiates a backwash cycle whenever a high differential pressure drop occurs across the strainer. A dual element switch is optional where operation requires the first switch to initiate the backwash cycle. The second switch activates on further increasing differential pressure and energizes a visual or audible alarm, calling for operator assistance.

**DIFFERENTIAL PRESSURE SWITCHES**

The differential pressure switch easily mounts on the control panel supports or attached to a bracket that is welded to the strainer body.



**CAUTION:** Never drill into the strainer body to mount instrumentation or support brackets.



**CAUTION:** Welding brackets to cast iron units is not recommended and should be avoided.

The switch is piped to the pressure connections furnished on the inlet/discharge nozzles of the strainer as shown in Fig 1. Customer must supply and run wiring and conduit between the differential pressure switch and the control panel. See Fig 2 for wiring connections.

**DIFFERENTIAL SWITCH ADJUSTMENT**

While it is possible to use other equipment than what is described below, any installation should have the items described here.

- Equipment to be furnished by customer:
- 2 calibrated pressure gauges
- 2 gauge valves with drain
- 2 tees, tubing, and fittings
- All items suitable for 1/4" NPT connections

Install all equipment as shown in Fig 1. Open the gauge valves and record the pressure readings at inlet/discharge of strainer operating at rated flow. The difference in reading is the "Normal" pressure drop across the system. Close both gauge valves. Set switch at "Normal Plus 2 psi" using the adjustment screw at the calibrated scale. To simulate a high differential pressure, carefully vent the "outlet" side gauge valve only. Note the pressure difference at which the switch is "activated." Using the adjustment screw on top of the switch, adjust until switch activates at the proper set point. The "High" alarm setting (optional) should be set at "Normal Plus 4 psi." Special applications may require other settings than those given above. Switch should be re-calibrated at least every 6 months.

**Figure 1**

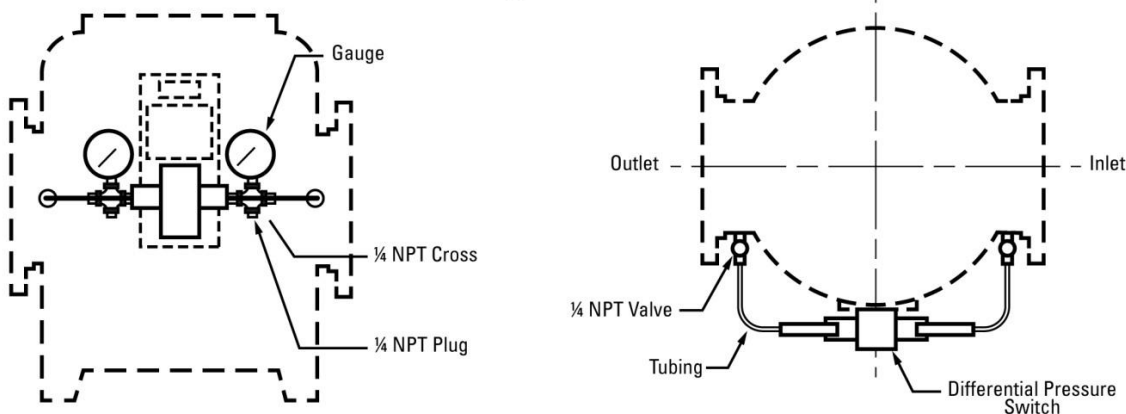

Note: Gauges and piping shown are furnished by customer.  
The differential pressure switch connection marked "high" should be connected to the inlet nozzle of the strainer.

## CONTROL PANEL DESCRIPTION

The ACS Series Control Panel is a rugged electro-mechanical unit made with industrial grade components and suitable for outdoor (NEMA 4) installation. The enclosure houses all components, is compact in size and is offered in two configurations:

**ACS-2S:** All standard features and includes motor and starter for backwash arm for 120 volt-single phase power supply

**ASC-3S:** All standard features plus motor starter for backwash motor and transformer for 460 volt-3 phase power supply

The ACS line of control panels allows operation either in the Manual or Auto modes. In the Manual mode, the strainer will continuously backwash. In the Auto mode, the strainer is allowed to backwash according to the preset timing cycle or when the differential pressure switch is activated.



NOTE: The customer determines the timing cycle length and changes it as required.

---

The control logic protects the strainer from sudden high quantities of solids or an improperly adjusted timer cycle. Whenever the differential pressure switch is activated, it overrides the timer circuit and opens the backwash valve.



NOTE: An On-Off cycling of the backwash valve will occur.

---

If frequent activation of the differential pressure switch is evident, the timer cycle must be re-set to backwash more often.

The panel door locates the selector switch and the indicating lights. The weatherproof rating is maintained as long as the lamp lenses are not broken and are not removed.

**OPERATING MODES  
DESCRIPTIONS**

**OFF MODE**

Power light illuminated; 120 VAC power applied across the “common” and “close” valve terminal connection. No other circuits energized.

**ON MODE**

Backwash valve open, strainer motor running, "BACKWASH ON" indicator illuminated, (monitor differential pressure switch, if differential pressure closes then "HIGH DIFFERENTIAL" indicator illuminated, HI-DP alarm contact closes).

**AUTO MODE**

Timer range limits for BACKWASH ON (valve open) is 1 to 1440 minutes.

Timer range limits for BACKWASH OFF (valve closed) is 1 to 1440 minutes.

**CHANGING THE BACKWASH  
TIMER SETTINGS**

To change timer settings press ALT button.

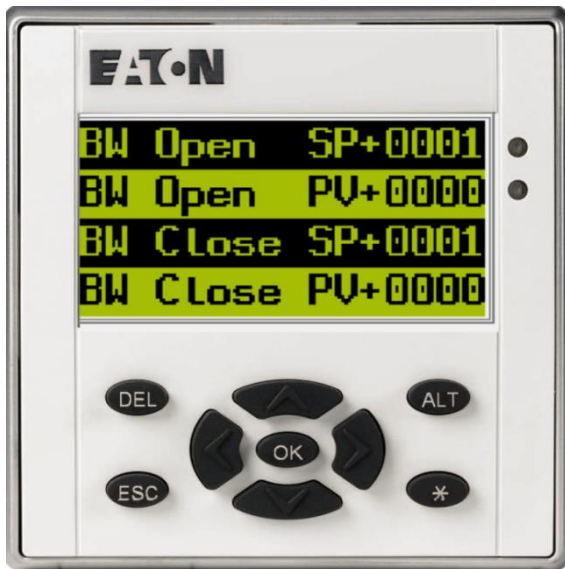

Use the UP or DOWN arrow buttons to move the cursor to select lines “BW Open SP+” or “BW Close SP+”.

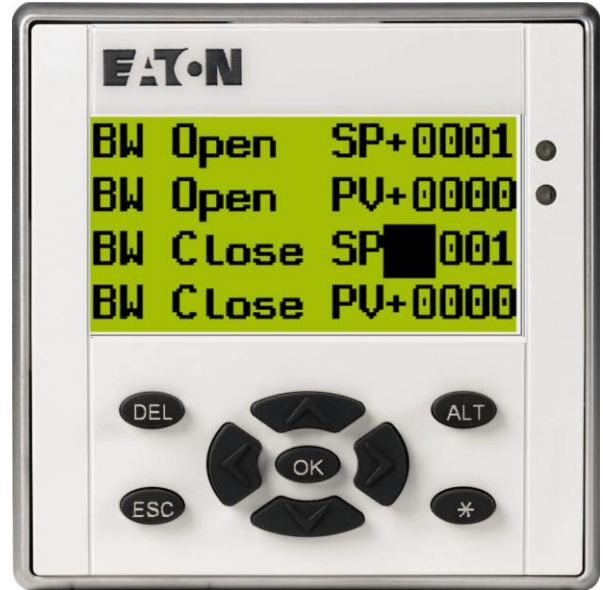

Press OK button to edit the BW set point.

Use UP and DOWN arrow buttons to increase or decrease value in selected number column.

Use LEFT and RIGHT arrow buttons to select the number column.

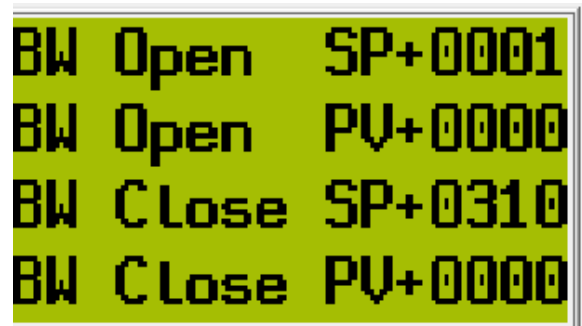

When the value is completed (shown set for 310 minutes/seconds above), press the OK button to move the cursor to BW timer set point select mode. Then press ESC key to leave BW timer edit mode.

**SMARTWIRE-DT ERROR  
MESSAGES**

The SmartWire-DT system has and the ability to detect most hardware errors. If a hardware error occurs the screen will display what device and node is damaged or disconnected. If more than one node is damaged or disconnected the screen will cycle through all errors present.



Motor Protector disconnect shown in the Open or Tripped position.

**SYSTEM ERROR MESSAGES**

**Motor Overload**

If there is a motor overload, the following message will flash on the screen.

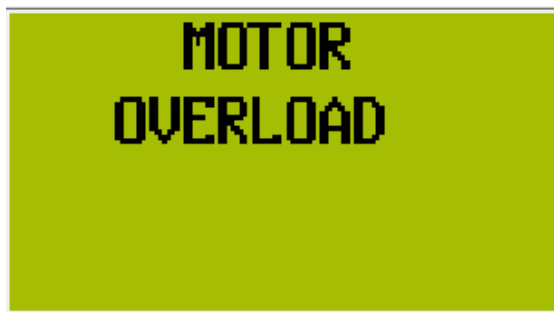

**Hi DP Backwash**

Hi DP backwash is indicated by the red LED and with a change of state on Hi DP backwash relay output



Motor Protector Disconnect Switch shown in the Closed position.

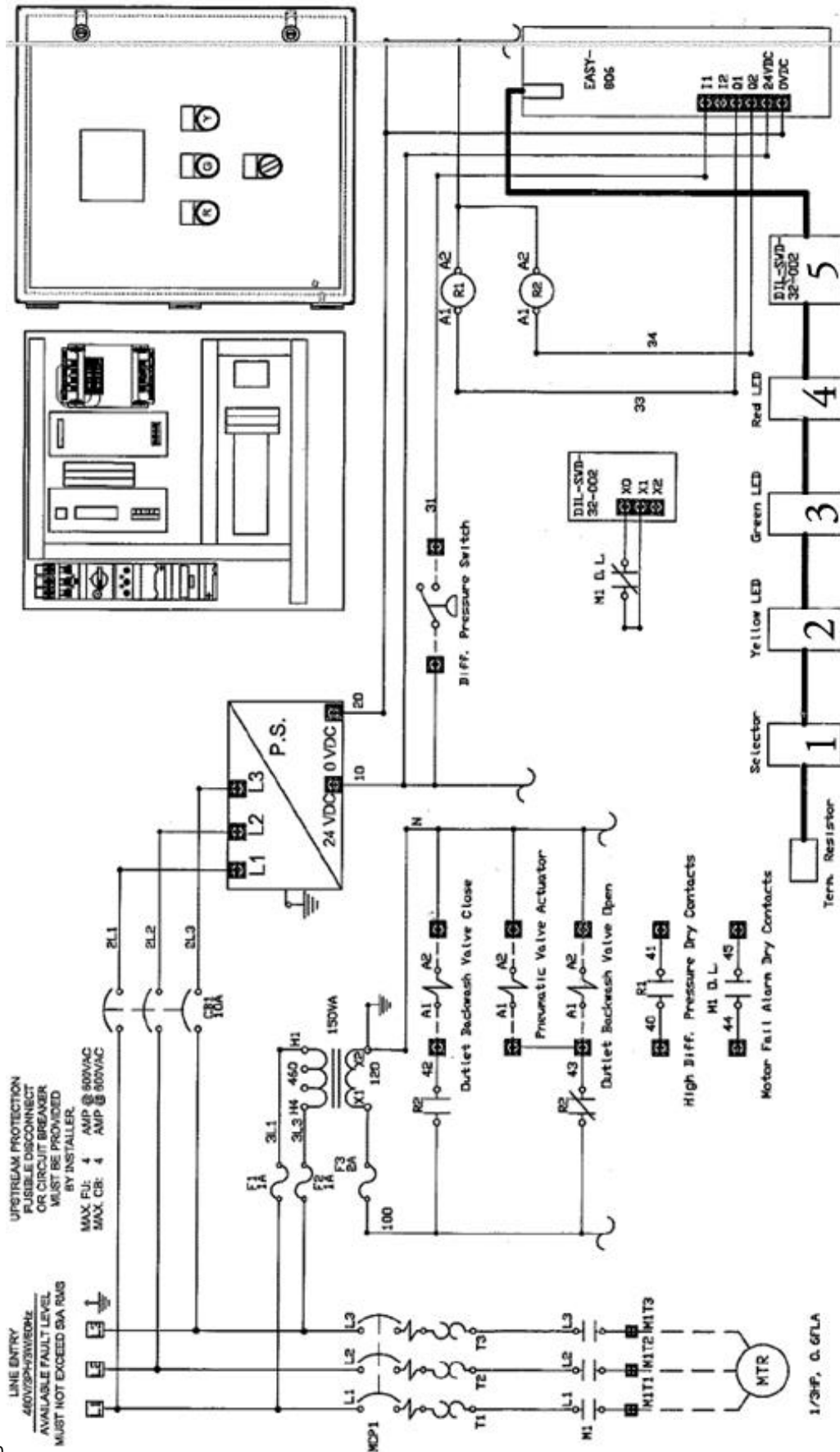



**TYPICAL INSTALLATION**

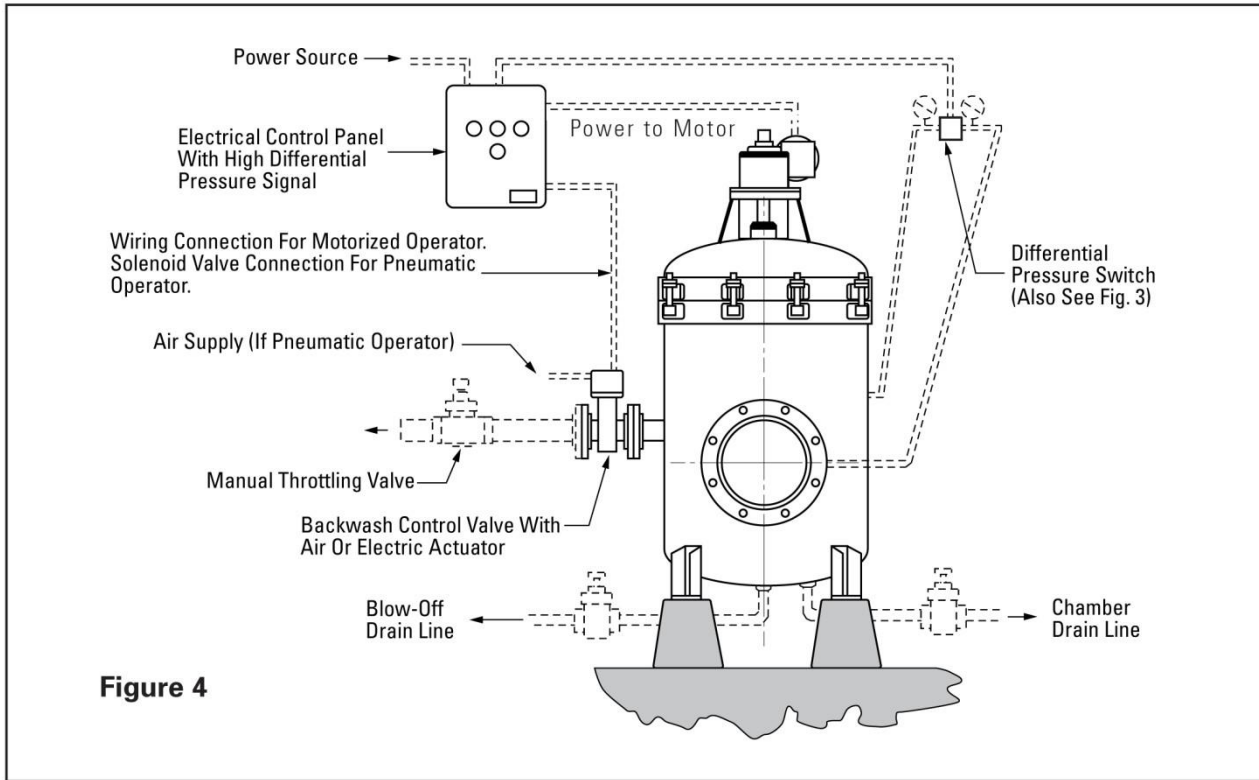

**Figure 4**

**North America**  
44 Apple Street  
Tinton Falls, NJ 07724  
Toll Free: 800 656-3344  
(North America only)  
Tel: +1 732 212-4700

**China**  
No. 3, Lane 280,  
Linhong Road  
Changning District, 200335  
Shanghai, P.R. China  
Tel: +86 21 5200-0099

**For more information, please**  
**email us at [filtration@eaton.com](mailto:filtration@eaton.com)**  
**or visit [www.eaton.com/filtration](http://www.eaton.com/filtration)**

US  
04-2020

**Europe/Africa/Middle East**  
Auf der Heide 2  
53947 Nettersheim, Germany  
Tel: +49 2486 809-0

Friedensstraße 41  
68804 Altlufzheim, Germany  
Tel: +49 6205 2094-0

An den Nahewiesen 24  
55450 Langenlonsheim, Germany  
Tel: +49 6704 204-0

**Singapore**  
100G Pasir Panjang Road #07-08  
Singapore 118523  
Tel: +65 6825-1668

**Brazil**  
Av. Ermano Marchetti, 1435 -  
Água Branca, São Paulo - SP,  
05038-001, Brazil  
Tel: +55 11 3616-8461

© 2020 Eaton. All rights reserved. All trademarks and registered trademarks are the property of their respective owners. All information and recommendations appearing in this brochure concerning the use of products described herein are based on tests believed to be reliable. However, it is the user's responsibility to determine the suitability for his own use of such products. Since the actual use by others is beyond our control, no guarantee, expressed or implied, is made by Eaton as to the effects of such use or the results to be obtained. Eaton assumes no liability arising out of the use by others of such products. Nor is the information herein to be construed as absolutely complete, since additional information may be necessary or desirable when particular or exceptional conditions or circumstances exist or because of applicable laws or government regulations.