

A measured step forward™

Operations & Maintenance Manual

5700 Series

Models 5710, 5720, 5730



Table of Contents

- General Description
- Installation Instructions
 - Location
 - Removal of Pump from Storage
 - Foundation
 - Piping
 - Power Connections
 - Application Consideration
- Operating Instruction
 - Pre-Start-Up Inspection
 - Test Runs and Start-Up
- Maintenance Instructions
 - Lubrication Schedule
 - Spare Parts Data
 - Replacing Spare Parts
 - Check Valve Cartridges
 - Replenishing Valve
 - Plunger or Plunger Spring
 - Diaphragm or Back-up Plates
 - Shift Ring 9.00
 - Motor Extension and Coupling
 - Hydraulic Fluid
- Troubleshooting Chart
- Gear Reducer Lubrication
- Spare Parts
- High Suction Lift Head
- Pneumatic Stroke Adjustment
 - Range Adjustment
 - Model 5701 Hydraulic Lock Adjustment
 - Maintenance
 - Parts Replacement
 - Models 5720 and 5730 Hydraulic Lock Adjustment
 - Parts Replacement
 - Trouble Shooting Chart
- Electric Stroke Adjustment
- Torque Specifications
- Plastic Heads and Check Valves

Always Give Pump SERIAL NUMBER When Ordering Spare Parts.

All equipment design and application data shown herein and related know-how are confidential and the property of Lutz-JESCO America Corporation. No use or disclosure there of may be made without our written permission.



General Description

The Cyclo/Phram™ pump is a positive displacement pump designed to meter liquids. A spring returned plunger, located in the main drive shaft, displaces hydraulic oil. The amplitude of the plunger stroke is controlled by positioning an eccentric shift ring against which the plunger pushes.

At zero capacity, the shift ring axis and the drive shaft axis coincide and no pumping action occurs. By offsetting the shift ring, the plunger stroke is increased and hydraulic oil is pulsed in the connecting passage leading to the diaphragm.

A molded teflon diaphragm separates the process and hydraulic fluids. The diaphragm moves in response to the pulsing fluid so that the volume of liquid on the process side of the diaphragm is alternately increased and decreased.

Double ball check valves prevent the reversal of flow of process fluid occurring through them. During the pump's suction stroke the volume of liquid in the process head is increased, the suction check valves are open, the discharge valves are closed and fluid is drawn into the pump. When the stroke is reversed, discharge occurs as the volume is decreased; the suction check valves are closed and the discharge valves are open.

The check valves are closed at the end of the suction and discharge strokes by their own weight. A positive differential pressure has to exist between suction and discharge to maintain proper check valve operation and to ensure precision and accuracy of operation.

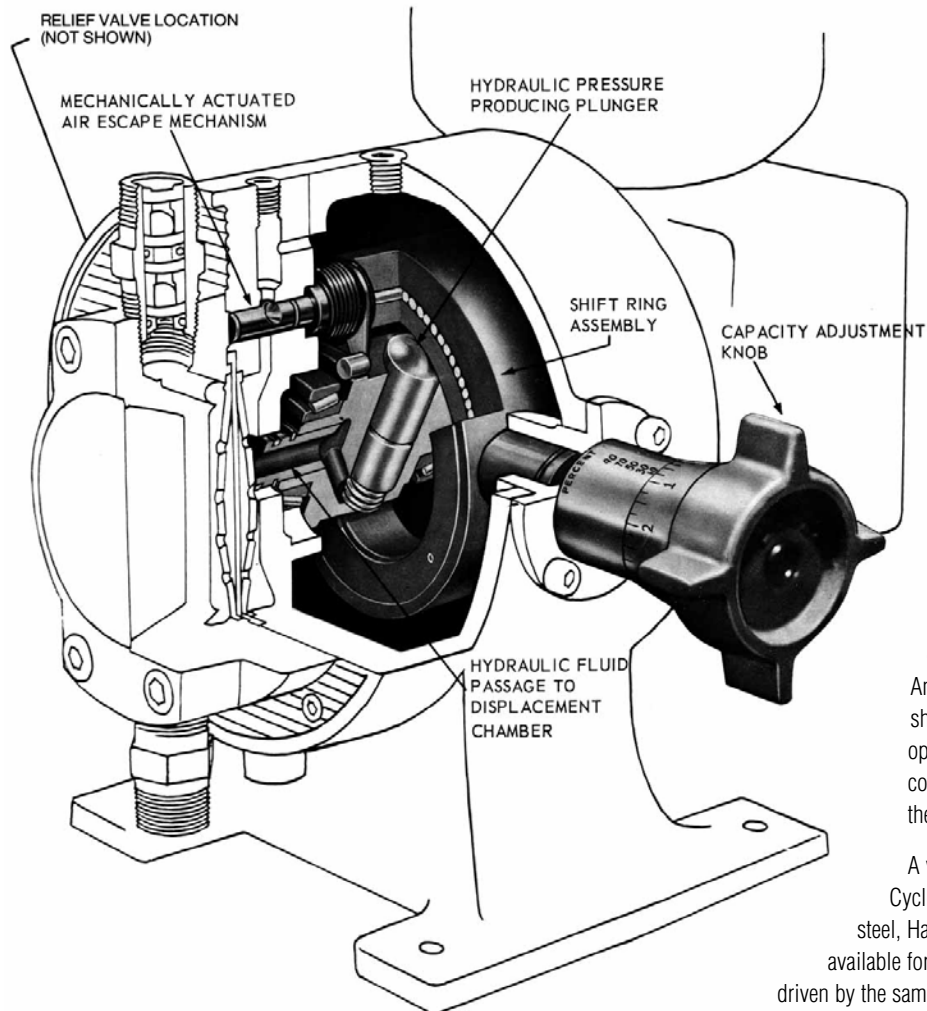

The diaphragm moves between two backup plates. The volume enclosed between the two plates is more than the maximum displacement of the plunger. In operation, the diaphragm flexes between the hydraulic side backup plate and a point determined by the plunger displacement.

The diaphragm contacts the backup plate near the end of the suction stroke and a preset oil replenishing valve operates to compensate for oil volume changes in the pulsing fluid due to slight leakage at seals, temperature variations, or when discharge capacity is changed.

The pump is equipped with an internal spring loaded relief valve to prevent pulsing fluid pressure, and therefore the process fluid pressure, from exceeding a preset pressure, usually 15 to 20% higher than the maximum discharge pressure. When the relief valve operates, oil is discharged to the pump casing reservoir during the discharge stroke. During the suction stroke the diaphragm contacts its backup plate and make-up oil is admitted through the oil replenishing valve. This will continue during each stroke until the discharge condition is corrected.

Closing off or "starving" the suction flow prevents the diaphragm from returning to its normal position during the suction stroke. Oil enters the pulsing fluid chamber through the replenishing valve in an

excessive amount. During the discharge stroke the diaphragm may contact the back-up plate on the process side. The hydraulic pressure rises to the relief valve pressure and any excess oil is discharged through the relief valve. Do not operate the pump in this manner as serious damage may occur to the diaphragm and other parts of the pump.

Cyclo/Phram™ pumps use flange mounted motors. The 5710, 5720 and 5730 pumps have motors that are mounted directly on gear reducers. The motor rating is dependent upon pressure and flow requirements.

The main drive shaft is mounted on oversized tapered roller bearings. An eccentric cam is cast on the drive shaft. The purpose of the cam is to operate an air venting mechanism which continuously releases entrapped air from the hydraulic system.

A variety of options are available with Cyclo/Phram™ pumps. Type 316 stainless steel, Hastelloy C, Carpenter 20 and plastic are available for liquid ends. Several pumps can be driven by the same motor. Pneumatic and electric stroke adjustment can be provided. Motors can be variable or fixed speed. Special provisions can be made for high temperatures, unusual fluid characteristics, or high suction lifts.

Installation Instructions

Location

The Cyclo/Phram™ pump should be located so that piping to and from the pump is as short and free of turns as possible. Short suction lines are very desirable. Since a flooded suction line helps prevent vapor binding of the pump, try to locate the pump below the liquid level in the suction vessel. See further recommendations under "Piping".

The Cyclo/Phram™ pump is adjustable while operating; allow sufficient space around the pump to permit easy access to the capacity adjustment mechanism and for routine maintenance.

Removal of Pump from Storage

Before the pump leaves the factory it is given a running test with cold water at operating pressure. Protective plastic caps will be placed over the suction and discharge opening. The pump is shipped fully charged with hydraulic oil suitable for operation above 50°F. Check to assure that the oil level is within ½" of the top of the casing. Remove the shipping plug in back of the pump housing. The gear reducer case should be checked for proper oil level prior to start-up, and vented plug installed.

Foundation

The Cyclo/Phram™ pump does not require a concrete foundation. It can be placed on any firm, level floor and need not be bolted down since the pump does not vibrate during operation. You may, however, wish to bolt down the pump to prevent damage to piping should the pump be jarred. Place the pump on a slightly raised platform above floor level if there is to be any hosing down in the area.

Piping

General

- Piping materials should be selected to be resistant to corrosion by the liquid being pumped. Select materials to avoid galvanic corrosion at points of connection to the pump suction and discharge cartridges. Use piping rated to withstand maximum pressure and temperatures of the system.
- Be certain that inside diameters of joints match properly; remove burrs and sharp edges, and avoid welding shot or splatter entering the lines. All lines should be blown out or flushed prior to making final connections to the suction and discharge cartridges.
- Do not spring piping to make connections. Provide for pipe expansion when hot fluids are pumped; support piping so that strain is not placed on the valve cartridges.
- Suction and discharge piping should be as short and straight as possible. Avoid unnecessary elbows. When possible use long sweep 90° fittings or 45° fittings. Piping should be sloped to eliminate vapor pockets.
- Flexible hose connections for both suction and discharge cartridges should be used for pumps with plastic liquid ends.

- Concentric bushings should be used only in vertical lines unless the piping arrangement permits natural venting of horizontal lines.
- Expansion loops, valves and similar equipment should be installed in positions to prevent formation of vapor pockets.

Suction Piping

- Use next larger pipe size than the suction connection of the pump. See the table of piping sizes for the recommended size for you pump.
- Suction piping must be absolutely tight. Test suction piping with air and soap solution for leaks. If possible, use tubing for the suction line since it has a smooth inner surface and is easily formed into sweep bends.
- Tight joints and sufficient net positive suction head are required for efficient pump operation.
- Use the Pipe Size Recommendation Table and Pressure Drop Chart to determine acceptable piping lengths. (Fig.B)
- Use an auxiliary feed tank close to the suction side of the Cyclo/Phram. pump if long suction lines from the main feed tank may be calibrated and used to check pump capacity by measuring the time required to draw a specific quantity of liquid from it. A typical auxiliary feed tank is shown Fig. A.

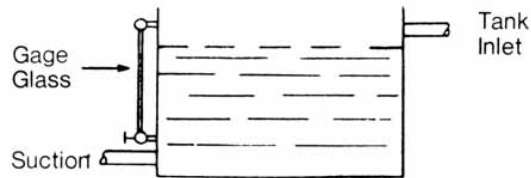

Figure "A". AUXILIARY FEED TANK

Pipe Size Recommendation Table

The size of the suction line is recommended to be one size larger than the size of the suction connections. The discharge line should not be smaller than the discharge connection. Tabulated below are the recommended sizes for the several pump models. Use a pipe schedule based on the pressure requirements.

Model	Suction		Discharge			
	Connection	Pipe Size	Tubing O.D.	Connection	Min. Pipe Size	Min. Tube Size
5710	½" NPTM	¾"	1"	½" NPTM	½"	¾"
	¾" NPTM	1"	1-1/8"	¾" NPTM	¾"	1"
5720	1" NPTM	1-1/4"	1-1/2"	1" NPTM	1"	1-1/8"
	1-1/4" NPTM	1-1/2"	1-3/4"	1" NPTM	1"	1-1/8"
5730	1-1/2" NPTM	2"	2-1/4"	1-1/2" NPTM	1-1/2"	1-3/4"
	2" NPTM	2-1/2"	2-3/4"	1-1/2" NPTM	1-1/2"	1-3/4"

Use the table above for the specific suction and discharge connections as supplied or as specified on the data sheet for the pump selected.

Pressure Drop Due To Acceleration

The pulsing nature of the fluid in the suction piping can cause rather substantial pressure drop because the flow must accelerate and decelerate on each stroke of the pump. The energy available to overcome these losses is generally the static head in the feed tank. The suction piping must be sized to assure a positive head at the pump. The pressure drop can be determined using chart. (Fig. B.)

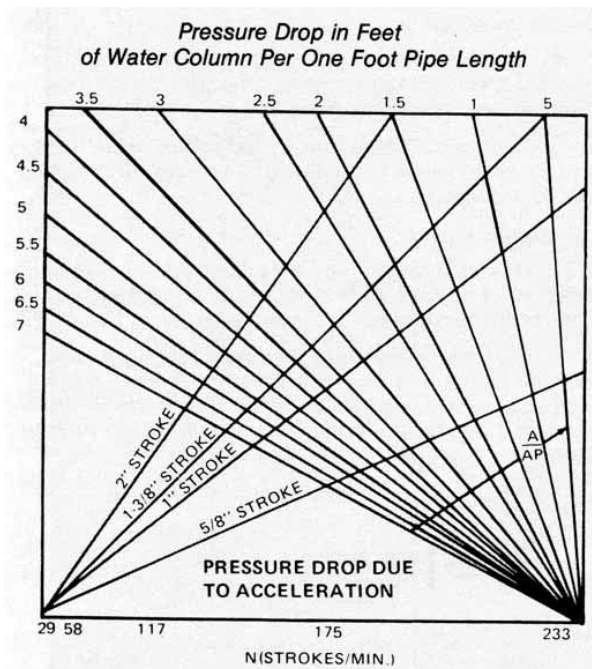

Figure "B".
Refer to instructions opposite for use of this diagram.

Instruction on Use of Pressure Chart

- Determine pump stroking speed, strokes per minute.
- Maximum stroke lengths are as follows:

Model 5710	1"
Model 5720	1-3/8"
Model 5730	2"
- Determine ID of pipe or tube.
- Determine plunger diameter of pump from Model Number as follows:

Model 5710	57X-1X-XXXX	19/32" dia.
	571X-3X-XXXX	1-1/16" dia.
Model 5720	572X-1X-XXXX	1-3/16" dia.
	572X-2X-XXXX	1-5/8"
Model 5730	573X-3X-XXXX	2-1/4"
- Determine ratio Plunger dia. and square the ratio to Pipe ID
Obtain the ratio (A).
(AP)

- Locate pump speed on chart and move vertically to stroke length line. Move horizontally to intersect (A) as
(AP)

determined above. Move vertically to read H/L, pressure drop in feet of water per foot of pipe length. The length is measured from the pump suction connection. Considering all head losses, the absolute pressure at the pump suction must be greater than the vapor pressure of the liquid being pumped. Allow .23 ft. of water for a gravity operated check valve.

Discharge Piping

- Install adequately sized pipe with a pressure rating in excess of the internal pressure relief valve setting.
- A positive pressure differential of approximately 30psi between the suction and discharge valves is recommended for proper seating of the ball checks. Should normal discharge pressure be less than the suction pressure, an artificial pressure head must be furnished. This can be accomplished by use of a back pressure valve, or vented riser in the discharge piping.
- Relief Valve – The Cyclo/Phram™ pump is equipped with an internal relief valve to protect the pump and motor from damage due to overpressure. This valve operates in the hydraulic oil system and does not contact the liquid pumped. It is normally factory set approximately 15% above the maximum discharge pressure shown on the order acknowledgment.

CAUTION! If the Cyclo/Phram™ pump is not the only pressure producing device in the system, an additional externally mounted safety valve will be required for system protection.

- For additional safety, a check valve should be included in the discharge line near the point where the line enters a high pressure process vessel.
- Provide shut off valve in both suction and discharge lines adjacent to the pump. Install unions in these lines, between the shut off valves and the pump to facilitate servicing the diaphragm head in those cases where it must be removed from the pump housing.
- Provide vent valve between the pump and discharge shut off valve to relieve pressure when pump is stopped.

Power Connections

- Check the nameplate rating of the motor and any auxiliary electrical equipment against the available power supply before making connections. Direction of motor rotation is not important.
- Motors furnished on Cyclo/Phram™ pumps are usually squirrel cage induction type. They have high starting currents (normally in the range of 300 to 350% of maximum running current). Be certain that the power source is rated to handle this type of load. Thermal overload heaters in motor starters should be rated based on full load current approximately 25% higher than indicated by motor nameplate.
- Standard wiring and conduit piping practice should be followed
- Provide adequate ventilation for the drive motor.

Application Considerations

Divided Flow

The discharge connection should not be manifolded to several points under pressure if precise metering to each point is required. If any point in a manifolded system is under slightly less pressure than the others, the total flow will not be evenly divided. A separate diaphragm liquid end should be provided for each point of discharge.

Positive Pressure Differential

Cyclo/Phram™ pumps are designed to operate against a positive pressure differential to assure proper seating of the ball check valves. Should your system include a condition where suction pressure exceeds discharge pressure, a means of providing a discharge pressure in excess of the suction pressure must be included in the installation. This can be accomplished by one of the following methods.

- A spring loaded diaphragm type valve designed to open on each discharge pulse from the Cyclo/Phram pump can be used as a back-pressure valve. The diaphragm in the valve protects the spring from corrosion and also prevents particle build-up from clogging the spring.
- Figure C represents a vented riser installation in the discharge piping of the Cyclo/Phram pump.

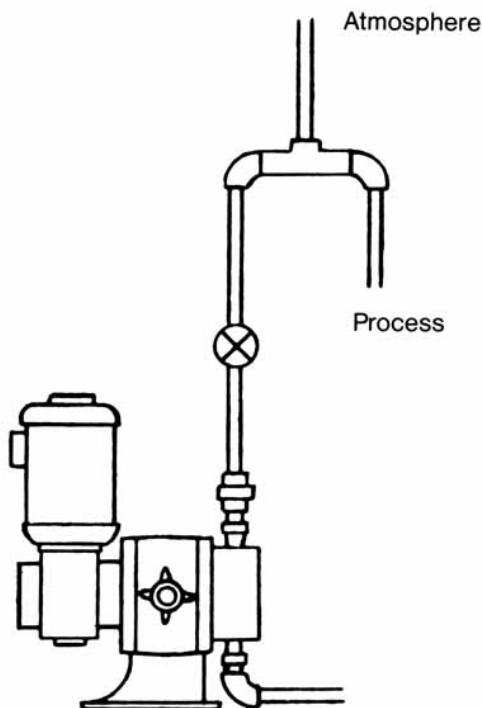

Figure "C". VENTED RISER

- Materials of the wetted parts have to be suitable for use with the fluid.

Refer To Drawing 071-021739, 072-021832, 073-021778, and 071-021847 For The Pump Model Used.

Pre-Start-Up Inspection

It is very important that the following items be checked after the pump is installed and before it is started for the first time.

Speed Reducer Lubrication

For 5710, 5720 and 5730 pumps, check gear case and fill to the correct level with the recommended oil. The worm gear driven speed reducer driving the Cyclo/Phram™ pump is a specially adapted commercial unit of high quality and is shipped full of the proper oil for normal operating conditions. Please follow the manufacturer's operating and maintenance instructions attached and be certain to remove the shipping plug and insert the vented plug in the gear case as directed.

Pump Housing Lubrication

The pump is shipped fully charged with hydraulic oil suitable for operation above 50°F. Check to assure that the oil level is within ½" of the top of the casing. Remove the shipping plug in back of the pump housing.

If initial pump operation will be under other than flooded suction conditions, first remove discharge check valve assembly and fill diaphragm cavity with process fluid or other compatible fluid. Replace discharge check valve assembly and make suction and discharge piping connections using piping procedures to guarantee leaktightness.

If pump is equipped with pneumatic stroke adjustment, refer to "Instructions for Pneumatic Stroke Adjustment" section of this manual.

Test Runs and Start-Up

Check oil level. Oil level should be above the top of the shift ring casting to within ½" of the top of the casing.

Priming – Hydraulic Side of Pump

- Unscrew the complete relief valve assembly approximately 4 turns.
- Operate pump at full capacity for 10 min. with suction and discharge valves open. This will clear any air out of the pumping side of the diaphragm and fill the hydraulic oil passages.
- Re-tighten the relief valve with approximately 20ft/lb of torque. The pump should now be ready for operation. Never operate the pump with the suction valve closed or the suction line restricted.

Priming – Process Side of Pump

- If sufficient suction head is available, let the fluid flow out through the discharge check valve. This operation will effectively purge the pump cavity of air and prime the pump.
- If the suction head is insufficient to meet the requirements of “a”, remove the discharge check valve cartridge and fill the diaphragm cavity with fluid.
- When viscous fluids are to be pumped, perform the priming operations as described in “a” and “b” (preceding with pump operating at about 50 capacity. This will help purge air from the cavity.

CAUTION – All suction line connections must be absolutely leak-tight to prevent air from being drawn into the lines, causing loss of prime.

Operating Conditions

Under normal operating conditions, the temperature of the gear end of fractional horsepower units can rise to 200°F without harm. See “Gear Reducer” instruction pages.

Capacity Calibration

Test runs to determine the exact capacity of the Cyclo/Phram™ diaphragm metering pump under specific operating conditions can be made after the initial break-in period of 12 hours. The pump should be set up to pump process fluid for this period at some nominal flow setting. Either measure the quantity collected from the discharge side of the pump or measure the drop in liquid level from a calibrated tank on the suction side of the pump during a given time interval.

High Pressure – Low Capacity Operation

The discharge and suction lines of Cyclo/Phram™ units operating at high pressures should be free of entrained air. To fill the system completely with liquid, operate the pump under zero discharge pressure for a short time prior to starting pressure tests. Since there is a possibility that air will enter the system due to liquid temperature changes after the Cyclo/Phram. pump has been idle for some time, provisions should be made for purging the system prior to restarting. This can be accomplished easily by installing a tee and a valve in the discharge line to allow fluid to be pumped to atmosphere upon start-up.

Capacity Adjustment

The capacity adjustment on all Cyclo/Phram™ pumps is calibrated in percent of maximum capacity. The approximate maximum capacity is shown on the Data Plate and the approximate output can be obtained by adjusting the capacity knob to the proper calculated percentage of this valve. To prevent the pump drifting from its set-point, the lock screw on the control knob should be tightened after each adjustment. Loosen the locking screw before readjusting the flow setting. The exact operating conditions since all Cyclo/Phram™ pumps are tested at the factory with water under standard conditions. Lock screw may be a set or thumb screw.

Maximum Operating Conditions

- Maximum discharge pressure is stamped on Cyclo/Phram. Data Plate.
- Pump maximum temperature: 180°F (Metal), 120°F (Plastic)
- Pressure effect on capacity: 1% per 100 psi
- Linearity: ±2% of maximum capacity.
- Operating interval: Cyclo/Phram. pumps are designed for continuous operation.
- Precision: ±1% repetitive accuracy with manual adjustment.

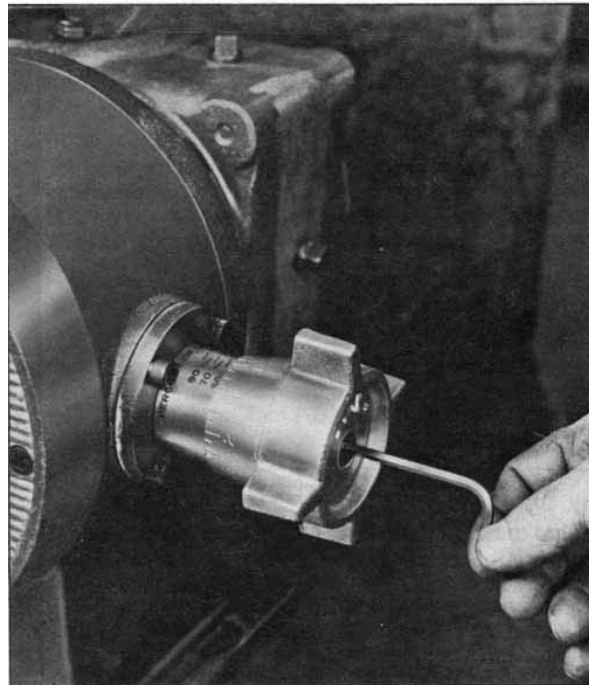

Micrometer adjustment being locked after setting.

Relief Valve

If it should be necessary to reset the relief valve to a value other than that set at the factory, use the following procedure. A discharge pressure gage is required for this test.

- Adjust pump to zero stroke
- Stop pump.
- Close discharge valve and open valve to operate discharge pressure gage.
- Adjust relief valve to maximum pressure by turning slotted screw clockwise until stop is reached.
- Start pump.
- Slowly increase stroke until discharge pressure gage shows desired relief pressure. This should be equal to the maximum operating pressure plus 15%. NOTE – The maximum operating pressure is stamped on the Data Plate.
- Reduce relief valve setting by turning slotted screw counter-clockwise until pressure gage indication starts to decrease.

- h. Slowly increase setting (CW rotation) until pressure settles out at desired setting.
- i. CAUTION – Do not overset the relief valve.
- j. If it is necessary to remove the relief valve from the pump, back-off the adjusting screw of the valve to unload the spring before removing the relief valve assembly from the pump.

Air Release Mechanism

All Cyclo/Phram diaphragm metering pumps incorporate a mechanically actuated air release system that continuously purges the hydraulic side of entrapped air. This system functions satisfactorily in either direction of drive shaft rotation and requires no attention or maintenance.

Maintenance Instructions

Lubrication Schedule

- The Cyclo/Phram™ pump has been designed to require a minimum of attention and to provide long and trouble-free service with maximum user satisfaction. In addition to following the gear box manufacturer's recommendations as to type of lubricant and frequency of oil change, it is recommended that the Cyclo/Phram™ pump casing be drained of lubricant at 6 month intervals. Refill with a high quality extreme pressure lubricant of approximately 800 SSU viscosity at 100°F. This is satisfactory for operation when ambient temperatures are as low as 50°F. To operate the Cyclo/Phram™ pump under ambient conditions to -10°F, dilute the oil with 25% kerosene.

Changing of the lubrications in the pump casing and gear box constitute the only periodic maintenance required of Cyclo/Phram™ diaphragm metering pumps.

To drain the oil, remove the oil drain plug and permit the oil to drain from the pump. Replace the drain plug. Fill the pump casing with oil through the oil fill hole. Oil level should be above the top of the shift ring casting to within 1/2" of the top of the casing. See priming instructions for repriming the hydraulic side of the pump.

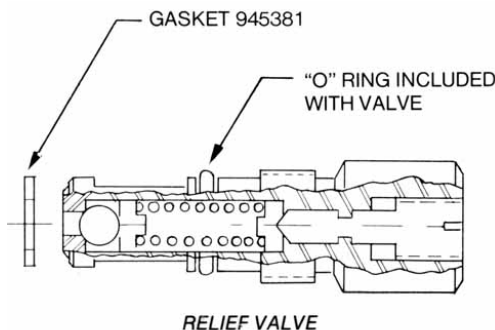

	Setting Range	Part No.
5710	50-200 psi	Y945733-01
	100-900 psi	Y945733-02
	800-4000 psi	Y945733-03
5730	25-1000 psi	Y948578-01
	1000-3000 psi	Y948578-02

- Motors are furnished with precision, pre-loaded bearings which are lubricated with an extra large supply of long-life grease for 10 years of normal operation.

Spare Parts Data

(A complete list of parts is included with instructions.)

- A small quantity of spare parts should be kept on hand to prevent delay in making emergency repairs.
- Replacement Parts – a. Cyclo/Phram™ pump parts – Please refer to the pump serial number and give the complete data from the nameplate when ordering spare parts. Specify the exact quantity of each part, and specify each part by name and number (refer to parts list and drawings in back of manual). In most multiplex

Quantity	Item Number	Description
1	34	Oil seal
1	40	"O" Ring
1	41	"O" Ring
1	56	"O" Ring
1	62	Plunger spring
1	68	Diaphragm
4	74	Valve seat
4	75	Valve guide half
2	76	Valve retainer
4	77	Valve ball check
4	78	Valve "O" Ring
1	66	Backup Ring/"O" Ring

pumps, the individual sides are of different diaphragm head materials and different plunger sizes. Please be certain to indicate on which side the spare parts are to be used. On the multiple head pumps, side number is indicated on the nameplate.

- Gear and Motor Parts - Gear reducers and motors furnished with Cyclo/Phram pumps are standard commercial units. Parts for these can be ordered from our factory or directly from the manufacturer. When ordering from the manufacturer be sure to include full nameplate data from the unit involved.

Replacing Spare Parts

- Check valve cartridges, (metal) – The Cyclo/Phram™ check valve cartridges incorporate replaceable and reversible seats sealed to the inner surfaces of the check valve body by TFE "O" rings. Should these valves require cleaning due to system contamination, or replacement of internals due to abrasive or corrosive wear, the cartridges can be disassembled by first removing the retainer ring (Item 76) and then driving out all internal parts with a short brass rod through the opposite end, being careful not to damage lower valve seat if the seats are to be reversed. All parts not showing excessive wear may be reassembled and the seats can be reversed to provide new seating surfaces Always use new TFE "O" rings to assure leaktight valve assemblies. The TFE "O" rings are split for ease of installation. Note: plastic check

valves DO NOT have reversible seats.

Tighten check valves in plastic heads only firm hand tight.

2. Replenishing Valve – The replenishing valve used in the Cylco/Phram. pump is preset to an opening pressure for proper pump operation. Under normal conditions, the replenishing valve should require no attention as it performs its function of automatically replacing any oil deficiency.

A standard socket wrench may be used for easy removal of the valve. Inspect the gasket and seal surfaces prior to re-assembly of replenishing valve. Be sure all parts are clean. Assembly torque is 48in./lb.

Repeat priming operations as described under “Test Runs and Start up”, section B, if it has been necessary to drain hydraulic oil from the pump.

3. Plunger or Plunger Spring – Disconnect suction and discharge piping and drain oil from pump housing. Remove coverplate (Item 67) making drive shaft (Item 60) accessible.

***CAUTION:** Care must be exercised when removing drive shaft (Item 60) from the shift ring (Item 6) to prevent the plunger (Item 61) from ejecting from its bore in the drive shaft. In Model 5720 and 5730 pumps, the plunger spring (Item 62) exerts considerable force against the plunger. In the same manner, care must be exercised in replacing the plunger in the drive shaft when reassembling.

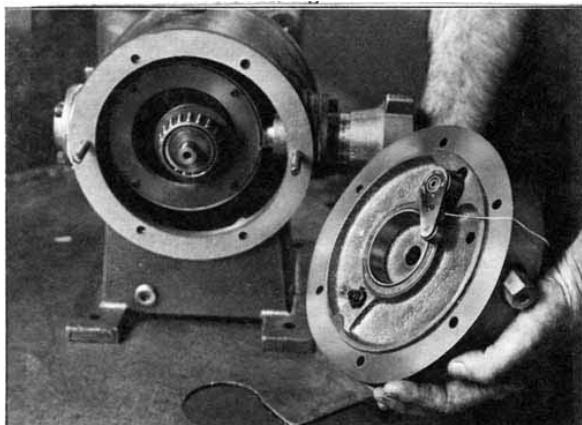

Index arm of air vent mechanism held by wire to clear cam on drive shaft.

Pull out drive shaft while holding plunger to prevent plunger and spring from jumping out. Install new plunger or spring (be sure guide pin is reinstalled) and push drive shaft back into bore of gear reducer output shaft while holding plunger in drive shaft. CAUTION!! Be care-

ful when removing or installing drive shaft into gear housing to prevent damage to shaft seal behind rear bearing.

Assemble coverplate (Item 67) to pump. Assemble torsion spring of air vent mechanism. Hold the index arm with a piece of wire or string to clear the cam (on the drive shaft) when the coverplate is reassembled to the pump.

Pull out the wire and tighten the coverplate bolts (Item 51). Fill the pump housing with new oil and connect suction and discharge piping. Operating Inst. Sec. B.

Coverplate bolts should be tightened evenly to 70-95 in./lb. of torque.

4. Diaphragm or Back-up – Disconnect suction and discharge piping. Remove diaphragm head bolts (Item 52) and diaphragm head (Item 71). Remove diaphragm (Item 68) with a knife or other pointed object. Install new diaphragm or back-up plates (Item 31 and 72) as necessary.

CAUTION!! The back-up plate on the hydraulic side of the diaphragm is always steel – it is stamped with the number 79 – the back-up plate on the process side is usually made of corrosion resistant alloy. Be certain when re-assembling the pump that the proper material is used on each side of the diaphragm. Assemble diaphragm head and tighten bolts evenly and crosswise to 75ft./lb. When plastic liquid ends are supplied, head bolts should be torqued to 20ft./lb./ NOTE: Be certain one of the holes in the outer circle of perforations in the back-up plates is in the topmost position when re-assembling the pump.

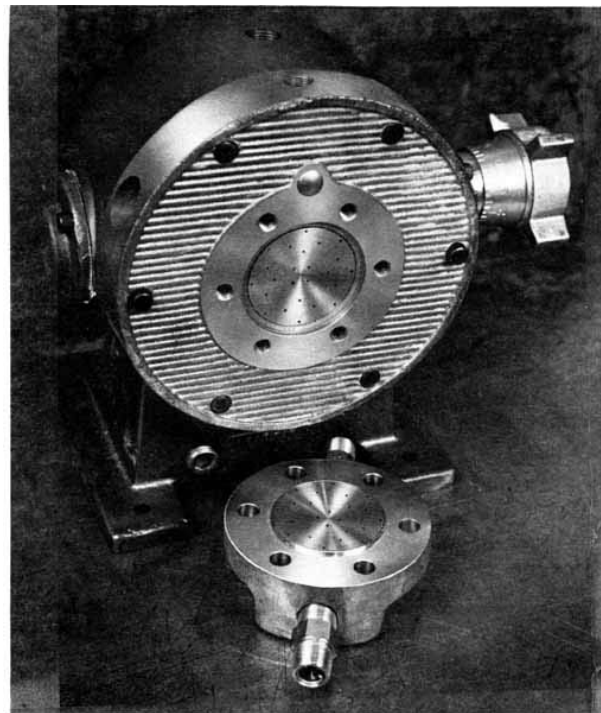

Outer holes in back-up plates in top position for air purging.

5. Shift Ring – Disconnect suction and discharge piping and drain oil from pump housing. Remove coverplate (Item 67) and drive shaft assembly (Item 60). In order to avoid a recalibration of the capacity adjustment, it is important to proceed as follows:

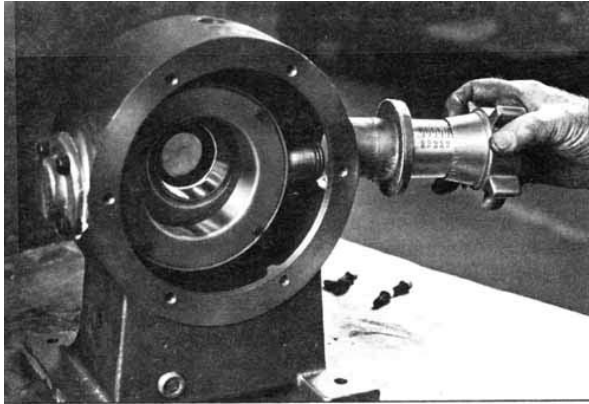

Assembling the adjustment screw into shift ring.

- Set adjustment below 0 until a definite stop is reached. Lock adjustment by tightening set screw (Item 48). Remove rear adapter bolts (Item 50 for 5710, 54 for 5720, and 47 for Model 5730) and unscrew complete adjustment assembly (Knob, Item 12; adjustment screw, Item 10; adjustment screw cap, Item 11*). Leave adjustment assembly locked until it is to be re-assembled to the pump. Remove shift ring assembly (Item 6) from housing and replace as an assembly if examination indicates excessive wear on the rollers or races.
- Replace shift ring assembly in pump housing
- The trunnion with "O" ring should be pointing toward the adjustment mechanism. Engage adjustment screw into shift ring and screw the complete adjustment assembly into the housing until it comes to a dead stop.
- Line up four holes and tighten bolts.
- Complete assembly by following steps described in Maintenance Instructions. Sec. C.

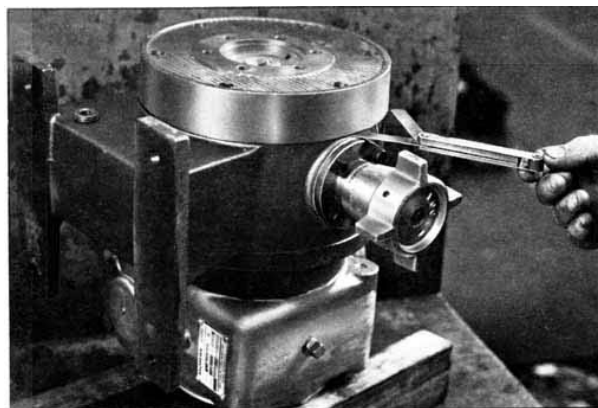

Measuring clearance between coverplate and housing to obtain proper gasket thickness.

When coverplate (Item 67) is replaced, new pump housing gasket shims (Item 2) must always be used. To install, tighten vent plugs on reducer to prevent oil running out reducer vent. Lay pump on reducer end cap with open housing up. Install seal bushing (Item 64) in drive shaft. Place coverplate (Item 67) on housing and insert 4 of 6 bolts, equally spaced. Do not install index arm assembly. Tighten bolts evenly finger tight and check clearance at circumference with feeler gauge until equal around periphery. Measure this clearance.

Select proper thickness gasket (Item 2) or series of gaskets to equal cap measured. Remove coverplate (Item 67) and assemble index arm assembly (Item 23) as instructed in Maintenance Instructions, Sec. C. Next assemble coverplate with proper gaskets and tighten

coverplate bolts evenly to 70-95 in/lb of torque. Bearings will be properly pre-loaded with no end play. Apply a thin coating of General Electric RTV-20 or Dow Corning Silastic to both sides of all gaskets.

6. Motor Extension and Coupling Connection (Refer to Drawing 071-021847) – Certain pumps are equipped with flexible couplings between the motor and the reducer drive shaft. It is necessary that special care be taken to assure a flat and secure assembly between the motor (Item 81) and the reducer assembly (Item 80).

Assemble in the following manner:

- Assemble coupling half (Item 3) on reducer input shaft. Assemble with key and set screw so that shaft end is flush with the face of its coupling half.
- Assemble remaining coupling half and key on motor shaft with its set screw so that shaft is flush with face of coupling. Make this assembly snug but not tight.
- Place rubber web on coupling jaws of coupling half in the reducer.
- Position the motor and join the coupling halves. Loosen the set screw on the motor shaft through the access hole and locate the motor on its mounting flange. Assemble and tighten motor mounting bolts.
- Tighten motor coupling half set screw thru access hole. Allow 1/32" to 1/16" clearance between the rubber web and the coupling half jaws.

Hydraulic Fluid

The hydraulic oil supplied with your pump is ZURN #80. This is a high quality extreme pressure lubricant, possessing excellent anti-rust and anti-wear protection. It is basically manufactured from a paraffinic crude, has very good oxidation and thermal stability and is non-corrosive to both steel and bronze. Its specific characteristics are as follows:

Viscosity, SUS @ 100°F 750-800
Viscosity, Index, Min. 95
Gravity, API @ 60°F 28-30
Flash, °F Min 460
Fire, °F Min. 480
Pour Point, Degs. Max. 0
Timken O.K. Load 60 lbs.

Additional oil may be obtained directly from:

O.F. Zurn Company
2738 N. Broad Street
Philadelphia, PA 19132

Trouble Shooting Chart

Problem	Possible Cause	Recommended Action	
Motor Overheats	1. Overload due to operation in excess of pump rating	1. Check actual operating conditions vs. pump nameplate data.	
	2. Power supply incorrect or voltage low	2. Check power supply vs. motor nameplate data.	
	3. Improper gear lubrication	3. Check type and level of lubricant. Replace if in doubt.	
Pump Fails to Deliver Rated Capacity	1. Leaky suction piping	1. Repair or replace defective piping.	
	2. Excessive suction lift	2. Relocate pump or suction vessel to reduce suction lift.	
	3. Liquid close to boiling point	3. Increase suction pressure, or cool liquid.	
	4. Suction starved	4. Increase suction pressure, or use larger size suction piping.	
	5. Liquid viscosity too high	5. a) Increase suction pressure.	
		b) Reduce liquid viscosity.	
		c) Increase suction piping size.	
		d) Use spring assisted diaphragm.	
	6. Internal relief valve set too low	6. Readjust to 15-20% above normal operating discharge pressure.	
	7. Worn or dirt ball valves or seats.	7. Replace or clean ball valves or seats. Seats are reversible.	
	8. Incorrect setting of micrometer capacity adjustment.	8. Adjust properly.	
9. Incorrect pump speed	9. Check line voltage and frequency vs. motor nameplate data.		
10. Worn seal bushing "O" ring	10. Replace "O" ring and back-up ring. Check drive shaft for end play.		
11. Air bubble accumulation in hydraulic chamber.	11. Air release mechanism inoperative – replace defective parts.		
Pump Fails to Operate	1. Blown fuse	1. Replace fuse after correcting cause of overload.	
	2. Open thermal overload in motor	2. Reset after correcting cause of overload. If malfunction recurs, check heater size	
	3. Low liquid level cutoff is actuated.	3. Fill suction tank	
	4. Open circuit in limit switches, timers, or other control devices in pump motor starter circuit	4. Reset.	
	5. Low line voltage.	5. Determine cause and correct.	
	6. Suction or discharge lines blocked.	6. Open lines.	
	7. Liquid frozen in pump or lines.	7. Thaw out pump.	
	8. Broken wire.	8. Locate and repair.	
	9. Pump not primed.	9. Refer to Paragraph A-3 of Operating Instructions.	
	10. Diaphragm cavity and internal passages air bound.	10. Refer to Paragraph B-1 of Operating Instructions.	
Pump Operates Erratically	1. Suction line breaks.	1. Repair or replace suction piping.	
	2. Insufficient suction pressure.	2. Pressurize suction tank or raise level in tank to increase suction pressure. Use spring assisted diaphragm.	
	3. Liquid close to boiling point.	3. Increase suction pressure or cool liquid.	
	4. Liquid viscosity too high.	4. a) Increase suction pressure.	
		b) Reduce liquid viscosity.	
		c) Increase suction piping size.	
d) Use spring assisted diaphragm.			
5. Internal relief valve leaks.	5. Repair or replace.		
6. Worn or dirty ball valves or seats.	6. Replace or clean ball valves or seats. Seats are reversible.		
Noisy Operation	1. Ball valves.	1. Ball valves make a clicking sound as they operate. Rattling noises may also be heard. On occasion, these noises are amplified by natural resonance of piping. These noises are normal.	
	2. Excessive backlash in gear reducer.	2. Adjust or replace gears if noise is objectionable.	
	3. End play in worm drive shaft.	3. Shim Shaft.	
	4. Improper lubrication.	4. Drain and refill gear case with proper lubricant.	
	5. Worn bearings.	5. Replace.	

Gear Lubrication

For Enclosed Worm Gear Units manufactured by Morse Div. of Borg Warner, Ithaca, N.Y.

A worm gear unit is only as good as the oil which is used. During the first few days of operation, a worm gear unit will run hot. Unless the temperature exceeds 200°F, there is no cause for alarm. Keep oil level up to check plug at all times. Change initial oil fill after 2 weeks operation and after that at six months to one year intervals depending on the service conditions.

Oil Company Name	Medium Oil	Heavy Oil
Amoco Oil Co.	Amoco Worm Gear Oil	Amoco Cyl. Oil No. 680
Exxon Corp.	Inca Oil	Navajo Oil
Gulf Oil Corp.	Cyclesstic TK 460	Cyclesstic TK680
Mobil Oil Corp.	Gulf Senate 460	Gulf Senate 680
Phillips Petroleum Co.	Mobil 600 W Cyl. Oil	Mobil 600 W Cyl. Oil
Texaco Inc.	Hector 2000-S	Hector 3000-S
	Vanguard Cyl. Oil	Honor Cyl. Oil
The companies and oils shown are typical. Any other make of oil of the same type and grade should be satisfactory. Your oil supplier should be able to select a similar oil. If an E.P. Oil is used, be sure it is not the type that is corrosive to a bronze gear. Units running at slow speeds should carry extra high oil level.	This oil is to be used in all worm gear reducers for operation at room temperatures from 15° to 60°F. Viscosity S.U. Range @ 210°F – 120-150	This oil is to be used in all worm gear reducers for operation at room temperature from 50° to 120°F. This oil should also be used for slow speeds (less than 100 RPM input) for operation at room temperatures from 15° to 60°F. Viscosity S.U. Range @ 210°F – 125-190

SPARE PARTS

ENCLOSED WORM GEAR UNIT

REPLACEMENT PARTS

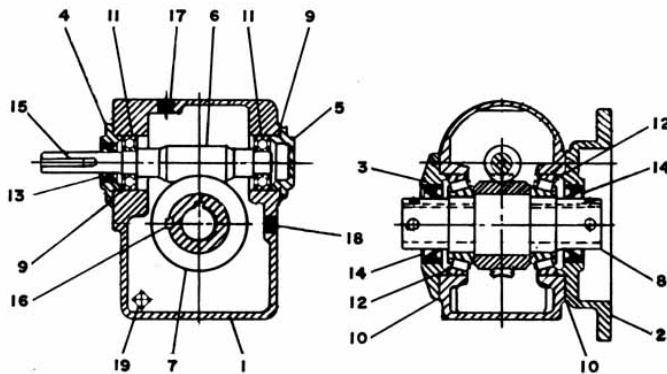

Model 18 SMRF

Models 20 SMRF, 25 SMRF, 30 SMRF, 35 SMRF

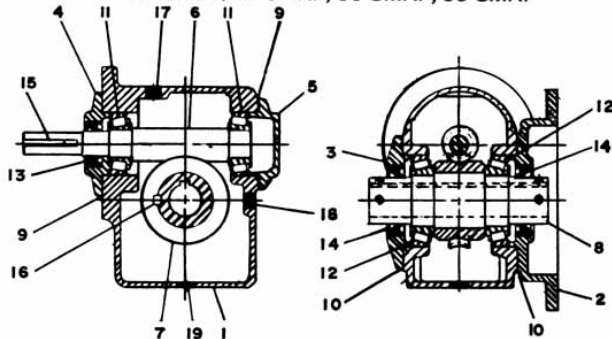

Piece No.	Name of Part
1.	Housing
2.	Mounting Flange
3.	Cover
4.	Bearing Retainer, Input Open
5.	Bearing Retainer, Input Closed
*6.	Worm
*7.	Worm Gear
8.	Output Quill
9.	Shim, Input (per set)
10.	Shim, Output (per set)
11.	Bearing, Input
12.	Bearing, Output
13.	Oil Seal, Input
14.	Oil Seal, Output
15.	Key, Input
16.	Key, Gear
17.	Oil Fill Plug
18.	Oil Level Plug
19.	Oil Drain Plug

*Worms and Gears for replacement sold only in matched sets.

NOTE: When ordering parts, be sure to give model number, serial number and ratio as shown on nameplate.

**Always Give Pump
SERIAL NUMBER
When Ordering Spare Parts**

High Suction Lift Head

Model 5710 and 5720 pumps in certain metallurgies can be supplied with a spring assisted diaphragm. High suction lift head pumps with this feature have two concentric springs (three for the 5720 pump) which apply pressure to the diaphragm during the suction stroke. The configuration is used in pumping viscous fluids (350 to 3500cps) or in drawing from a subatmospheric source.

The general arrangement of the springs is shown below. The springs exert considerable force so care must be exercised in disassembly and assembly. The preferred method is to remove the pumps from the gear reducer and place it on the bench so the head is horizontal. Remove any two head bolts 180 degrees apart and replace them with threaded rods – alternating back and forth until the springs are completely expanded. Assembly is accomplished by reversing the above procedure. Care should be taken to assure concentricity of the springs as the head is tightened.

Threaded rod data	
5710 pumps	7/16-14
5720 pumps	5/8-11

Special Heads

High Suction Lift

A spring assisted diaphragm is available in most metals and has an internal configuration different from the regular heads. This configuration is shown on the drawing below. When reassembling this assembly be sure that spring seats and springs are located concentrically around the center of the diaphragm pad.

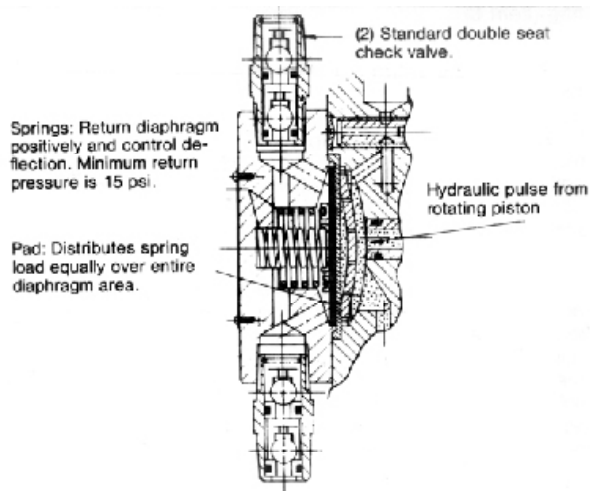

Instructions for Pneumatic Stroke Adjustment, 5710, 5720 & 5730 Pumps

A Conoflow Commandaire Model 31 positioner with a B-50 actuator is used to adjust the stroke (flow) of the Cyclo/Phram™ pump. For instructions and parts lists refer to Conoflow Commandaire Model 31 and B-50 manuals, respectively. The appropriate piping schematic is shown in the Commandaire Manual.

The actuator operates satisfactorily with a minimum supply pressure of 40psi and is limited to 100psi, maximum. For best results the cushion pressure should be adjusted to two thirds of the supply pressure. Air should be regulated and filtered.

Range Adjustment

The signal range of actuators can be varied by installing a special restrictor. Turning the square-head screw on top of the restrictor clockwise will decrease the signal range.

Model 5710 Hydraulic Lock Adjustment (Refer to drawing 071-021847)

Added to the pump on the opposite side of the actuator is a hydraulic adjustment lock. A relief valve and a replenishing valve provide the means for intake and discharge of hydraulic oil to or from the locking chamber. The replenishing valve is factory-set and does not require field adjustment. The relief valve has to be adjusted for operating conditions and is factory-set based on the maximum operating conditions stated in the pump order – no further adjustment is necessary. When discharge conditions are changed, field adjustment must be made according to the following procedure:

- Loosen lock nut (Item 94) while holding set screw (Item 46) in place.
- Start pump and develop maximum discharge pressure.
- Adjust pump to 90% flow rate.
- If actuator stem bounces, tighten set screw (Item 46) until stem remains fixed. Tighten lock nut (Item 94) while holding set screw (Item 46) fixed.
 - If actuator stem remains stationary, loosen set screw (Item 46) until stem starts oscillating, then tighten set screw until stem remains stationary. Tighten lock nut (Item 94) while holding set screw (Item 46) fixed.

There are three springs (Item 95) available to cover discharge pressure conditions as listed below. The proper spring is supplied with the pump to cover maximum discharge pressure conditions for the pump ordered.

Spring Number

Plunger Size	303180	303181	303182
19/32"	0 - 1800	1800 - 3480	3480 - 4000
1-1/16"	0 - 440	440 - 960	960 - 1700

Maintenance

The hydraulic lock does not require maintenance. For other Model 5710 pump spare parts, refer to enclosed parts list.

Parts Replacement

To remove actuator, disconnect air supply and signal line. Remove screw (Item 85) and pointer (Item 86). Remove set screw (Item 48) with air pressure locked above the piston and the stem extended. Turn complete actuator counterclockwise until shift ring extension (Item 83) disengages from shift ring (Item 6). To replace actuator, slip collar (Item 84) onto actuator stem. Thread actuator stem to shift ring approximately 17-18 turns, making sure that one flat on the actuator shaft faces up. Tighten screw (Item 87) and connect air lines. Operate pump and adjust signal air pressure to 3psi. Adjust pump to zero output at positioner zero set. Replace set screw (Item 48), pointer (Item 86), and screw (Item 85). Line up pointer with zero on scale.

Models 5720 & 5730 Hydraulic Lock Adjustment (Refer to Drawing 072-061491)

On the Model 5720 and 5730 pumps the hydraulic lock adjustment is located on the same side as the actuator. A relief valve and a replenishing valve provide the means for controlling the intake and discharge of hydraulic oil to and from the locking chamber. The replenishing valve is factory set and requires no adjustment. The relief valve must be adjusted for operating conditions; it is factory-set based on the maximum operating conditions stated in the pump order. No further adjustment should be necessary.

Should discharge conditions be changed, field adjustments should be made to obtain best operation. Proceed as follows:

1. Start the pump and develop the maximum discharge pressure to be used.
2. Stroke the pneumatic actuator slowly through its full stroke several times to purge any trapped air from the locking chamber. Back off the knurled pressure adjustment screw (Item 103) to unload the spring (Item 101) so that any air may be bled off quickly.
3. Retighten the knurled pressure adjustment screw (Item 103) and set actuator for 90% flow.
4. If the connecting rod is moving excessively adjust the knurled pressure adjustment screw (Item 103) by tightening down on the spring until the oscillation stops or reaches an acceptable limit as given in the chart on page 15.
5. If adjusting the relief valve is not effective in damping the oscillations at maximum load, repeat the air bleed procedure, "2" above.
6. If the actuator is unable to return to the minimum stroke position, decrease the relief valve loading to reduce the damping pressure, or raise the cushion pressure under the actuator piston by adjusting the pressure regulator. Set the cushion pressure as high as possible while retaining satisfactory operation, at about two thirds of the supply pressure.

Part Replacement (Refer to Drawing 072-061491)

To remove the actuator, extend the actuator stem with pressure, and lock air pressure above the piston. Disconnect the air supply and signal lines. Remove screw (Item 104) and pointer (Item 113). Remove set screw (Item 108).

Turn complete actuator counterclockwise until connecting rod (Item 107) disengages from the shift ring (Item 6). Do not remove the adaptor flange (Item 109) from the housing (Item 1); this should only be done as part of a complete disassembly of the pump.

To replace the actuator, first tighten the connecting rod (Item 107) into the actuator stem female thread. Use approximately 30ft/lb of torque and "Thread Lock" Grade Loctite compound on the threads.

With air pressure loading the piston so that the shaft is extended, place the locking collar (Item 121) over the stem and carefully guide the connecting rod through the seals to engage the threads in the shift ring (Item 6). Rotate the entire actuator as a wrench to bottom the connecting rod threads in the shift ring.

Rotate the actuator counterclockwise to line up the mounting holes. Reassemble the cap screws (Item 50), reassemble the set screw (Item 108) in the locking collar (Item 121), set the collar position so that the pointer will be at 100% on the scale. Tighten the set screw with 5in./lb. of torque.

Reconnect air lines. Operate pump and stroke actuator through several cycles to purge air from the locking chamber. Adjust air signal to 3psi. Adjust pump flow to zero using the zero adjustment screw on the actuator positioner. Relocate the locking collar (Item 121), if necessary to permit the pointer to be aligned with zero on the scale. Reassemble the pointer (Item 113) with screw (Item 104).

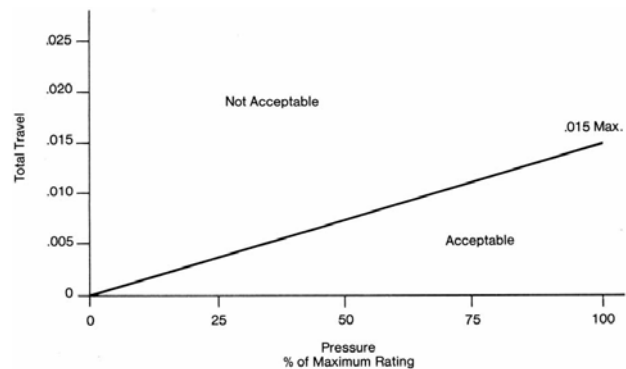

Trouble Shooting Chart

Problem	Possible Cause	Recommended Action
Actuator Stem Bounces	1. Hydraulic lock relief valve set too low.	1. Readjust relief valve setting.
	2. Hydraulic lock relief valve or replenishing valve leak.	2. Clean valves.
	3. Worn-out seals.	3. Replace seals.
	4. Air in locking chamber.	4. Bleed air from system.
	5. Cushion pressure too low.	5. Raise cushion pressure
Actuator does not move to full stroke	1. Hydraulic lock relief valve set too high.	1. Readjust relief valve.
	2. Air supply too low.	2. Increase supply pressure.
	3. Actuator stem too far engaged into shift ring.	3. Correct engagement.
	4. Collar located too close to pump.	4. Correct collar location.
	5. Cushion pressure too high.	5. Decrease cushion pressure.
Actuator does not return to zero	1. Cushion pressure too low.	1. Increase cushion pressure.
	2. Collar located too close to actuator.	2. Correct collar location.
Operating range shifts	1. Shift ring extension, Model 5710, connecting rod, Model 5720, 5730, loose.	1. Retighten connecting rod in actuator and shift ring. Check tightening of set screw and locking collar.
	2. Actuator zero shift.	2. Readjust zero on positioner.

Instructions for Electric Stroke Adjustment Models 5710 and 5720 Only

The electric stroke adjustment incorporates a Honeywell "Actuator" motor mounted on the side of the pump. The details are shown on the drawing below.

This motor moves clockwise and counterclockwise through an arc of 150° maximum. This motion results in full stroke adjustment.

The Actionator is used with or without a proportioning relay. The proportioning relay is used when the control signal is a 4-20 MA (or similar) signal. The feedback slidewire in the Actionator motor has a resistance of 135 ohms and is matched to the relay. The electric stroke adjustment is used without a relay when the control signal is a 115 V.A.C. signal. The feedback slidewire in this model is 1000 ohms.

A complete explanation of the operation of the Actionator motor and the proportioning relay can be found in the booklets shipped with the pump: Instructions 95-8131, M640A, D, M940A Actionator motors. Instructions, Proportioning Relay, R7165A.

Part Number	Quantity	Description
1	1	Motor
2	4	Hex Head Cap Screw
3	1	Motor Frame
4	4	Socket Head Cap Screw
5	2	Gasket
6	1	"O" Ring
7	1	Retaining Ring
8	2	Set Screw
9	1	Disc, Seal
10	1	Drive Adapter
11	1	Lead Screw
12	1	Cap Adjusting Screw
13	4	Lock Washer
14	4	Washer
15	1	Retainer, Spring Scale
16	1	Scale
17	2	Set Screw
18	1	Pointer
19	1	Bushing
20	1	Screw, Special
21	1	Spring, Torsion
22	1	E.S.A. Gummed Label

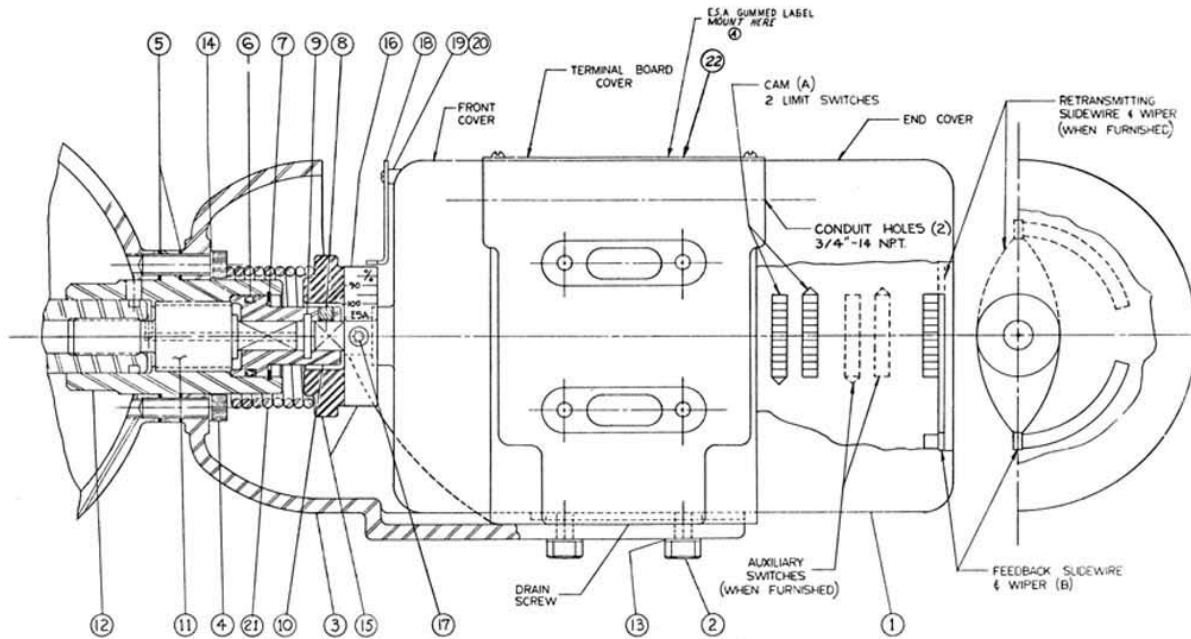

Electric Stroke Adjustment Assembly

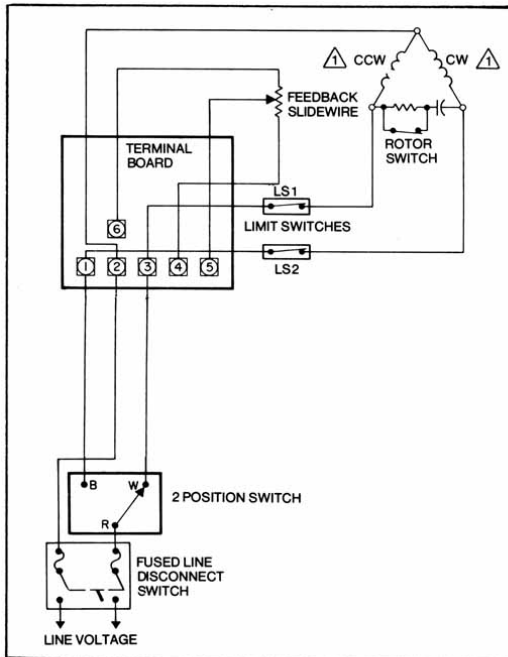

⚠ Direction of rotation as viewed from output end of motor.

M640A Internal Wiring (Two Auxiliary Switch Model Shown).

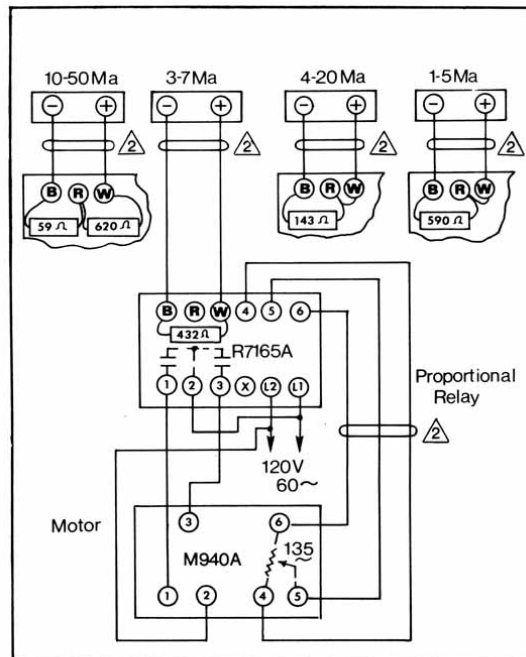

Typical Connection Diagram for Proportional Control of a Motor

NOTE: Resistors connected across B-R terminals must be $\pm 1\%$; those across R-W may be $\pm 5\%$.

⚠ Run these leads in conduit containing no line voltage wiring (to avoid inductive pickup).

Torque Specifications

Torque Specifications 5710 Pump		
Item No.	Description	
73	Check Valve (plastic head)	60-100in/lb
73	Check Valve (all other metals)	1/2", 45ft/lb
		3/4", 60ft/lb
52&53	Head Bolts (plastic)	20 ft/lb
52&53	Head Bolts (metal)	75 ft/lb
50	Adjustment Cap	12 ft/lb
51	Cover Plate	70-75 in/lb
47	Relief Valve	20 ft/lb
24	Replenishing Valve	4 ft/lb
87	Pneumatic Cylinder	20 ft/lb
Torque Specifications 5720 Pump		
Item No.	Description	
73	Check Valve (metal)	75-80 ft/lb
73	Check Valve (cast iron)	50ft/lb
73	Check Valve (plastic)	9-13ft/lb
52&53	Head Bolts (metal)	75 ft/lb
52&53	Head Bolts (plastic)	20 ft/lb
50	Adjustment Cap	35-40 ft/lb
51	Cover Plate	70-95 in/lb
28	Relief Valve	20 ft/lb
24	Replenishing Valve	46-50 in/lb
Note: 1" Metal Check valves with twin locking nuts only:		
	Lower Lock Nut	110-120 in/lb
	Upper Lock Nut	33-37 in/lb
Torque Specifications 5730 Pump		
Item No.	Description	
73	Check Valve (metal)	155-165 ft/lb
73	Check Valve (cast iron)	50 ft/lb
73	Check Valve (plastic)	9-13 ft/lb
52&53	Head Bolts (metal)	75 ft/lb
52&53	Head Bolts (plastic)	20ft/lb
51	Cover Plate	70-95 ft/lb
50	Adjustment Cap	35-40 ft/lb
57	Relief Valve	20 ft/lb
24	Replenishing Valve	46-50 in/lb

Plastic Heads and Check Valves

The polypropylene diaphragm head differs from the conventional metal heads in that it does not have a separate diaphragm plate. The head is machined from polypropylene bar stock; the contour of the diaphragm plate is machined into the head (see drawing).

Plastic Head (Polypropylene)

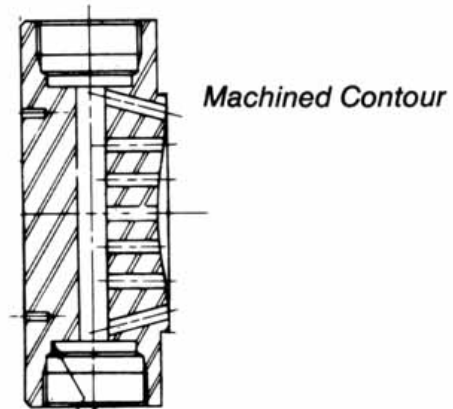

The check valves for the polypropylene pumps are different from the metal check valves. The plastic check valves have two different configurations, suction and discharge.

NOTE: IF THESE VALVES ARE REVERSED THE PUMP WILL NOT OPERATE PROPERLY

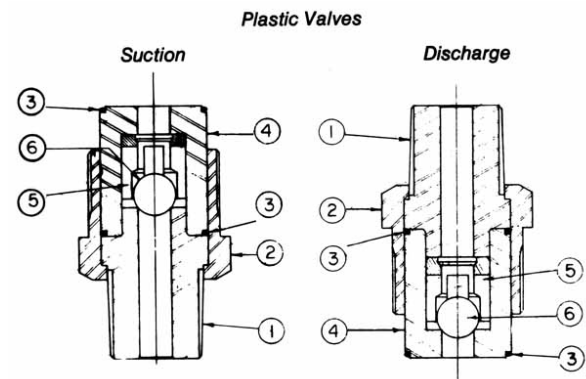

NOTE: PRIOR TO ASSEMBLY CHECK THE FIT OF THE BALL IN THE INSERT. THE BALL MUST MOVE FREELY.

Part No.	Part Name	Materials
1	Upper Body	Polypropylene
2	Clamp	416 S/S
3	"O" Ring	Teflon
4	Lower Body	Polypropylene
5	Insert	Polypropylene
6	Ball	Ceramic

DRAWING 071-021739

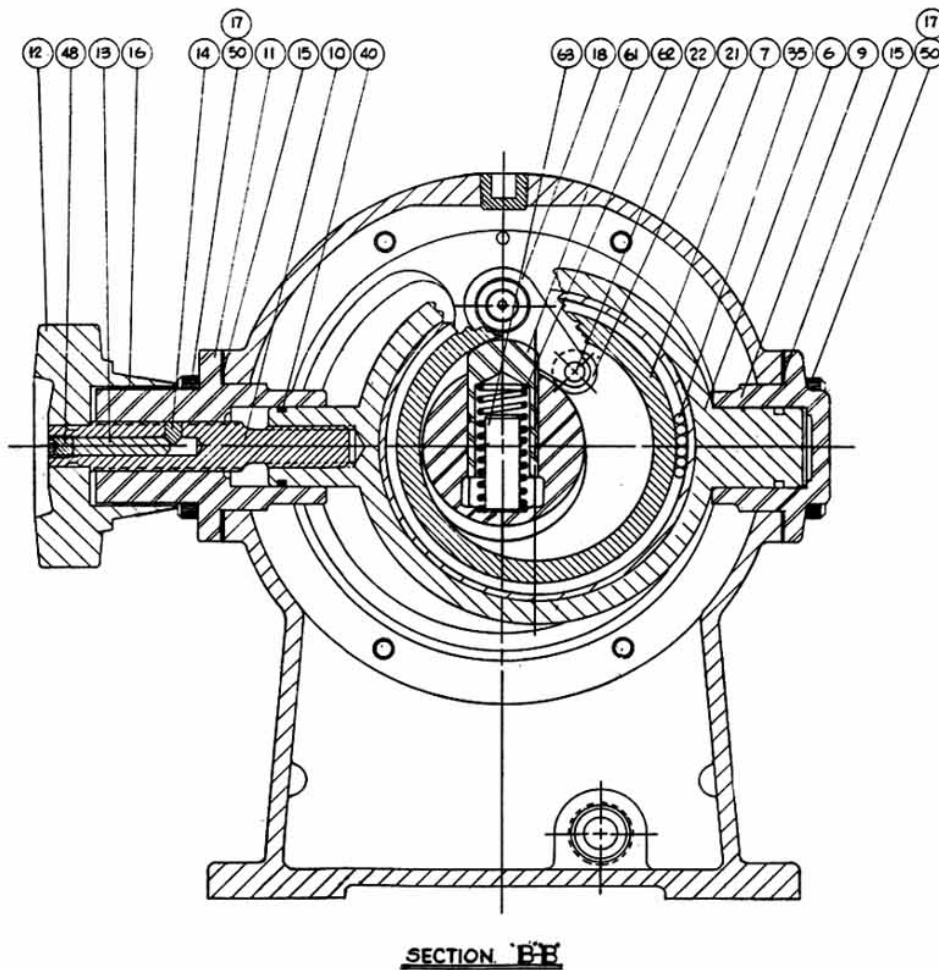
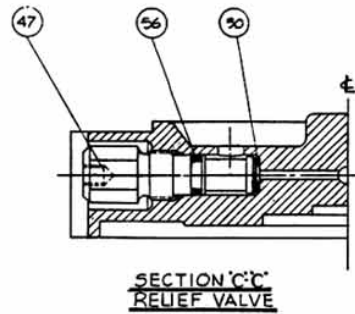

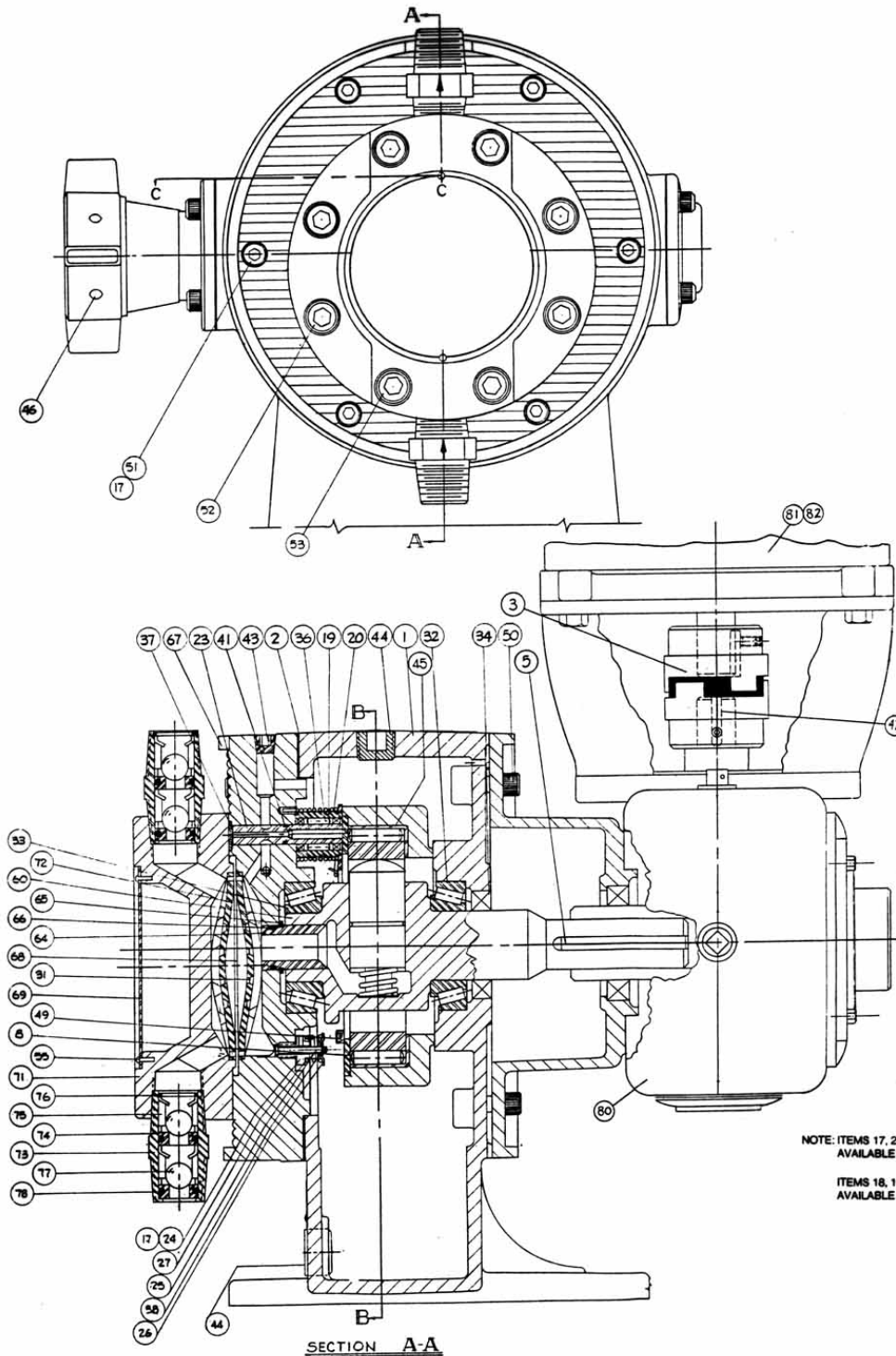

ITEM NO.	NAME
1	PUMP HOUSING
2	GASKET
3	COUPLING
4	
5	KEY
6	SHIFT RING
7	REACTION RING
8	RETAINING RING
9	CAP-SHIFT RING
10	ADJUSTING SCREW
11	CAP-ADJUSTING SCREW
12	KNOB-ADJUSTING SCREW
13	LOCKPIN
14	INSERT
15	GASKET-CAP
16	STROKE ADJUSTING SCALE
17	WASHER
18	ARM INDEX
19	HUB INDEX
20	SPRING
21	ROLLER
22	ROLLER PIN
23	AIR ESCAPE SHAFT
24	BODY-REPLENISH VALVE
25	STEM
26	SPRING RETAINER
27	SPRING
28	
29	
30	WASHER
31	DIAPHRAGM PLATE
32	BEARING-CUP
33	BEARING-CONE
34	OIL SEAL
35	ROLLER BEARING
36	CLUTCH
37	EXPANSION PLUG
38	RETAINING RING
39	
40	O-RING (Shift Ring)
41	O-RING (Air Bleed)
42	KEY, COUPLING
43	PIPE PLUG
44	PIPE PLUG
45	INSERT, SHIFT RING
46	SET SCREW
47	RELIEF VALVE
48	LOCKING SCREW
49	SOC. HD. CAP SCREW
50	SOC. HD. CAP SCREW
51	COVER PLATE BOLT
52	DIAPHRAGM HEAD BOLT
53	SOC. HD. CAP SCREW
54	
55	DRIVE SCREW
56	O-RING (Relief Valve)
57	
58	
59	
60	DRIVE SHAFT
61	PLUNGER
62	PLUNGER SPRING
63	GUIDE PIN
64	SEAL BUSHING
65	RETAINING RING
66	O-RING/BACK-UP RING
67	COVER PLATE
68	DIAPHRAGM
69	NAMEPLATE & DATA PLATE
70	
71	DIAPHRAGM HEAD
72	DIAPHRAGM PLATE
73	BODY CHECK VALVE
74	SEAT CHECK VALVE
75	GUIDE HALF CHECK VALVE
76	RETAINER CHECK VALVE
77	BALL CHECK VALVE
78	O-RING CHECK VALVE
79	
80	GEAR REDUCER
81	MOTOR
82	MOTOR KEY

NOTE: ITEMS 17, 24, 25, 26, 27, 28 (AIR RELEASE INDEX ARM) AVAILABLE AS ASSEMBLY ONLY.

ITEMS 18, 19, 21, 22, 36 (REPLENISHING VALVE) AVAILABLE AS ASSEMBLY ONLY.

DRAWING 072-021832

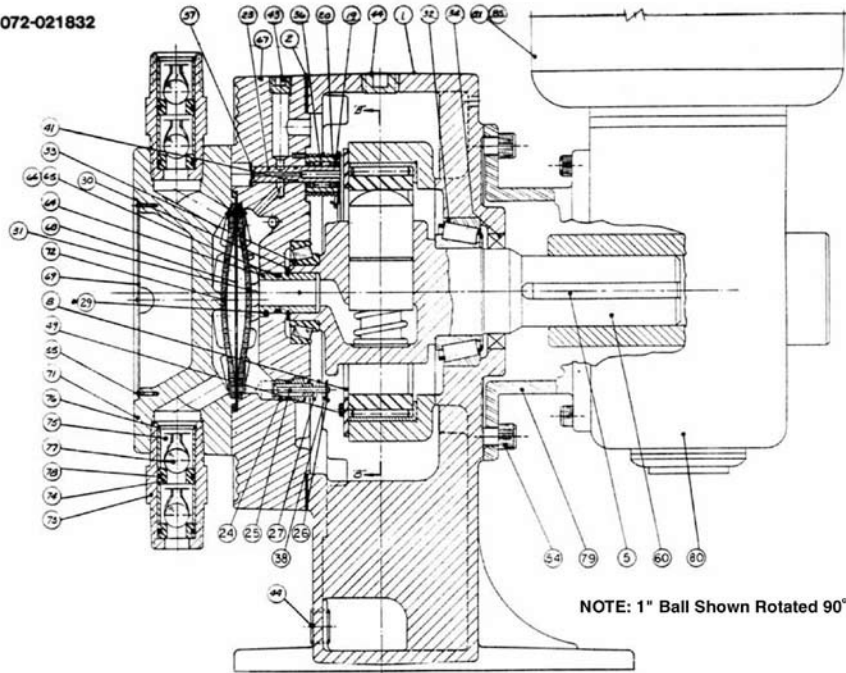

Parts List Cyclophragm 5710 Pump Model wth Pneumatic Actuator Postioner
Reference Drawing 071-021847

Part No.	Description	Part No.	Description	Part No.	Description	Part No.	Description
1	Pump Housing	25	Stem	51	Screw Soc. HD. Cap	77	Ball, Check Valve
2	Gasket	26	Spring Retainer	52	Screw Soc. HD. Cap	78	"O" Ring, Check Valve
3	Coupling	27	Spring	53	Screw Soc. HD. Cap	80	Gear Reducer
5	Key	30	Gasket, Relief Valve	55	Drive Screw	81	Motor
6	Shift Ring	31	Diaphragm Plate	56	"O" Ring, Relief Valve	82	Insert, Shift Ring
7	Reaction Ring	32	Bearing – Cup	60	Drive Shaft	83	Shift Ring Extension
8	Retaining Ring	33	Bearing – Cone	61	Plunger	84	Collar
9	Cap, Shift Ring	34	Oil Seal	62	Plunger Spring	85	Screw, Pointer
10	Key, Coupling	35	Roller, Bearing	63	Guide Pin	86	Pointer
11	Flange, Adaptor	36	Clutch	64	Seal Bushing	87	Screw, Hex HD. Cap
12	Pneu. Cylinder w/Positioner	37	Expansion Plug	65	Retaining Ring	88	Back-up Ring
15	Gaset, Cap	38	Retaining Ring	66	"O" Ring/Back Up Ring	89	Screw, Replenishing Valve
16	Stroke Adjusting Scale	40	"O" Ring, Shift Ring	67	Coverplate	90	"O" ring, replenishing Valve
17	Washer	41	"O" Ring, Air Bleed	68	Diaphragm	91	Spring, Replenishing Valve
18	Arm, Index	43	Pipe Plug	69	Nameplate & Dataplate	92	Ball, Replenishing Valve
19	Hub, Index	44	Pipe Plug	71	Diaphragm Head	93	Nut, Hex
20	Spring	46	Set Screw	72	Diaphragm Plate	94	Spring
21	Roller	47	Valve, Relief	73	Body, Check valve	95	Follower, Ball
22	Roller Pin	48	Set Screw	74	Seat	96	Ball
23	Air Escape Shaft	49	Screw SC, HD, Cap	75	Guide Half, Check Val.	97	Seal
24	Body, Replenishing Valve	50	Screw Soc. HD. Cap	76	Retainer, Check Valve	98	Motor Key

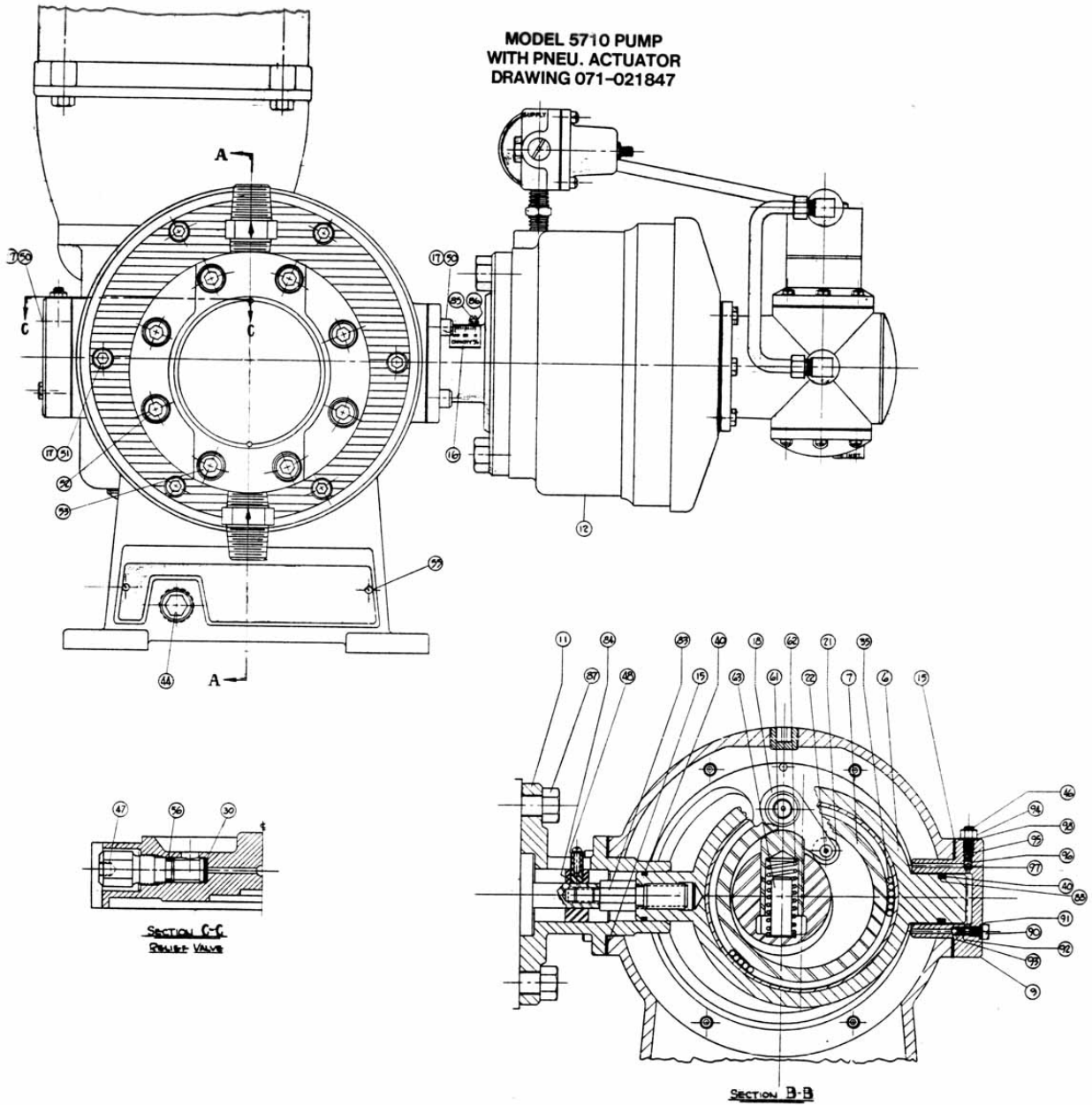

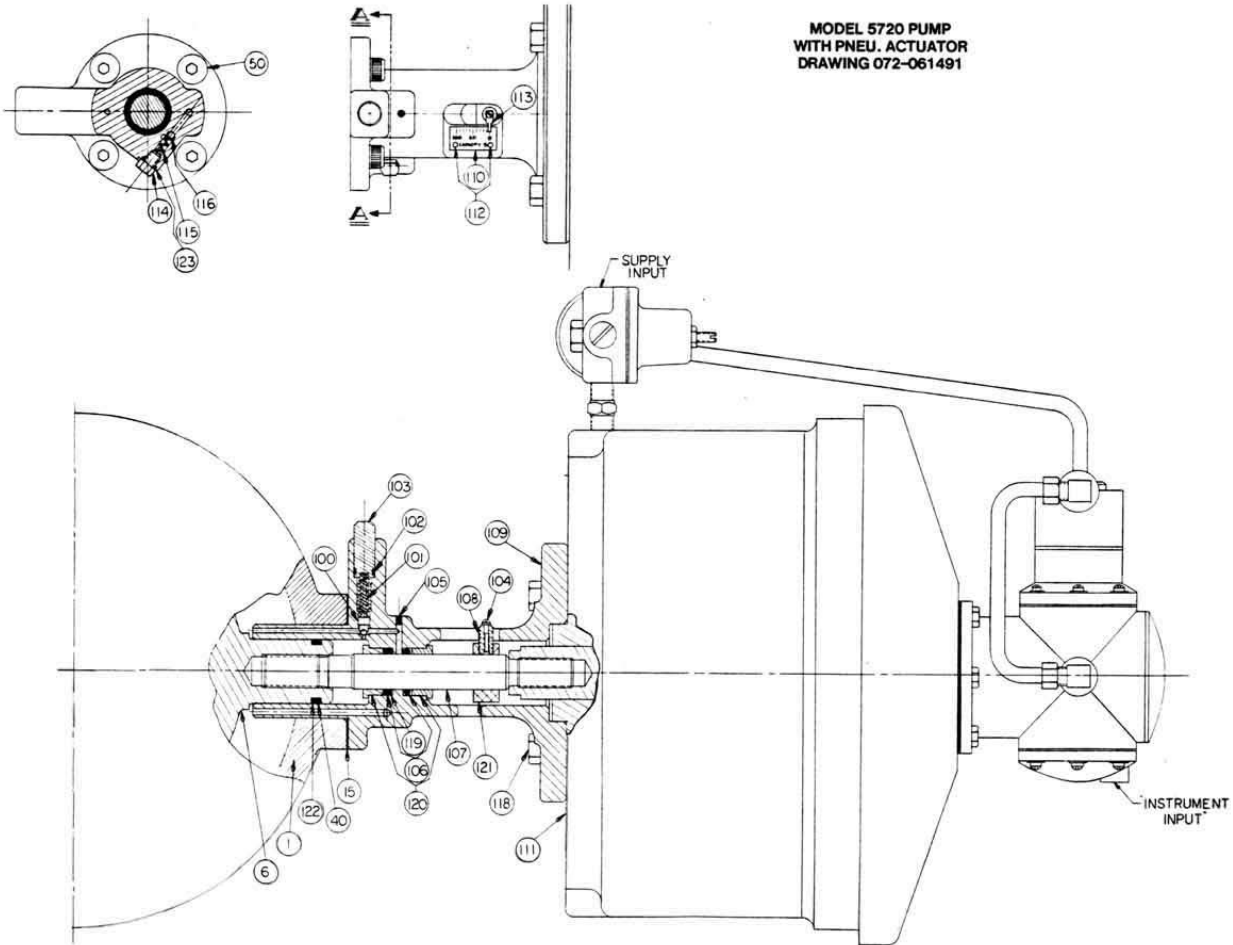

Parts List Cyclophragm 5720 Pump Model wth Pneumatic Actuator Postioner
Reference Drawing 071-061491

Part No.	Description	Part No.	Description
1	Housing	110	Stroke Scale
6	Shift Ring	111	Pneumatic Actuator
15	Gasket	112	Drive Screw
50	Cap Screw	113	Pointer
100	Ball & Follower, Relief Valve	114	Screw, Replenishing Valve
101	Spring, Relief Valve	115	Spring, Replenishing Valve
102	"O" Ring, Adj. Screw, Pressure	116	Ball, Replenishing Valve
103	Adjustment Screw, Pressure	117	
104	Pointer Screw	118	Hex Head Screw
105	Taper Pin	119	Back-Up Ring, Connecting Rod
106	"O" Ring, Connecting Rod	120	Seal Retainer
107	Connecting Rod	121	Collar
108	Set Screw, Collar	122	Back-Up Ring, Trunnion
109	Adapter Flange	123	"O" Ring, Replenishing Valve
		40	"O" Ring, Trunnion

DRAWING 072-021832

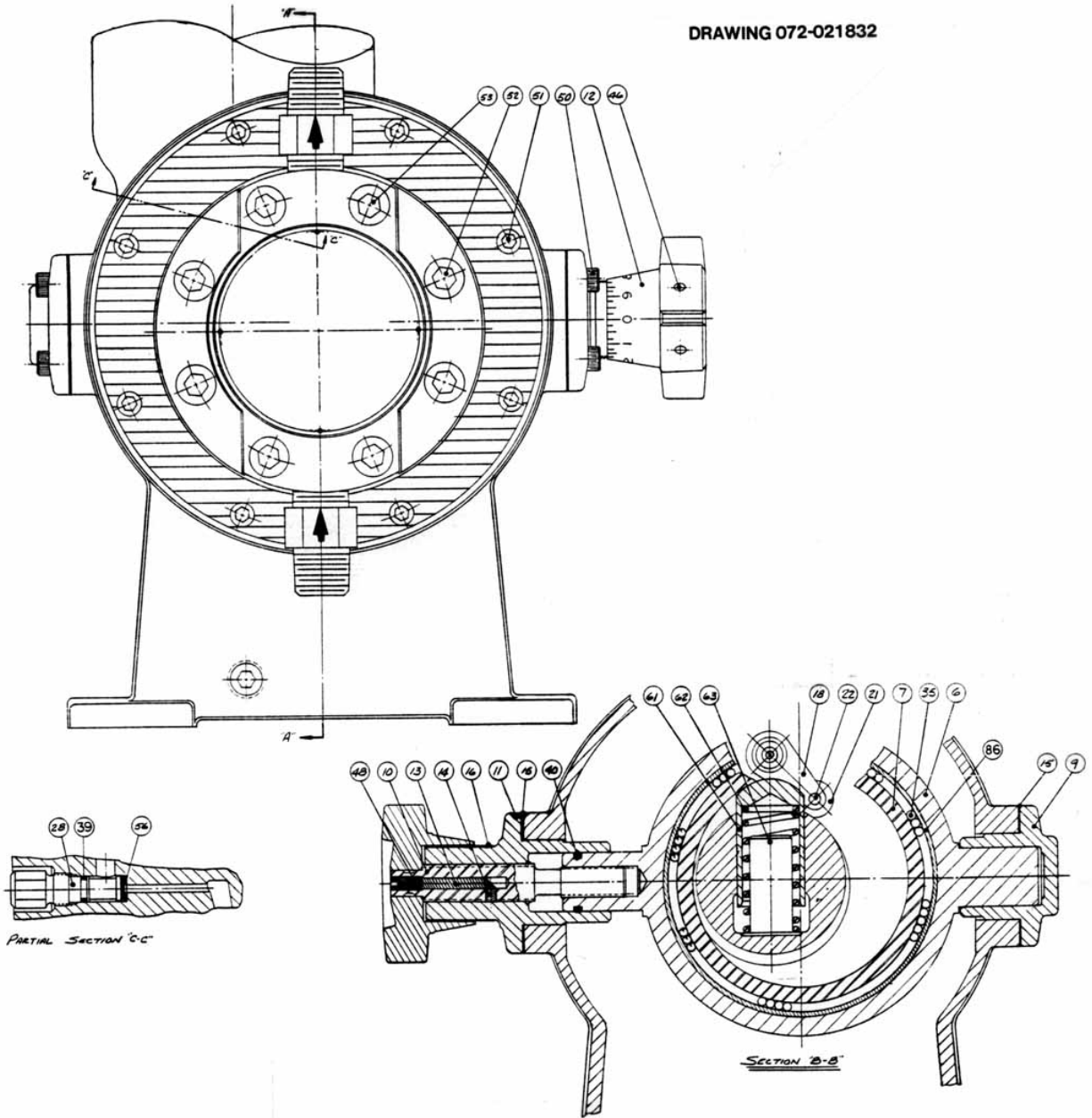

DRAWING 072-021832

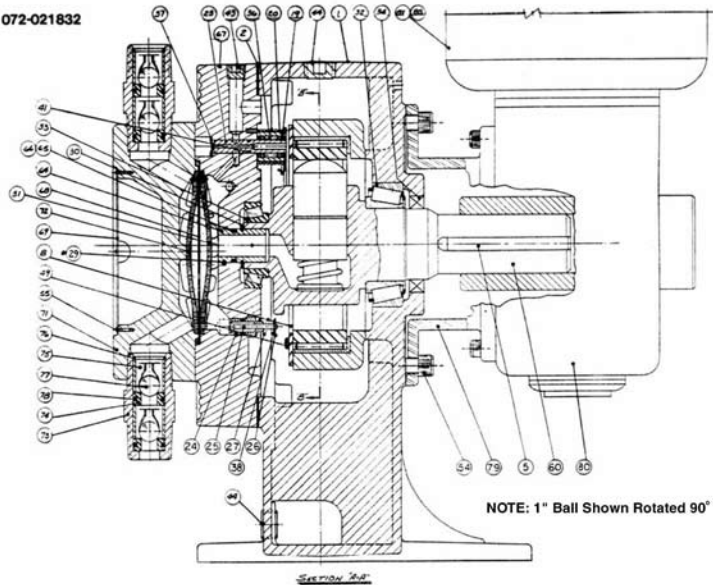

Parts List Cyclophragm 5720 Pump Model
Reference Drawing 072-021832

Part No.	Description	Part No.	Description	Part No.	Description
1	Pump Housing	28	Relief Valve	55	Drive Screw
2	Gasket	29	Ball	56	Alum. Washer
5	Key	30	Retaining Ring	60	Drive Shaft
6	Shift Ring	31	Diaphragm Plate	61	Plunger
7	Reaction Ring	32	Bearing-Cup	62	Plunger Spring
8	Retaining Ring	33	Bearing-Cone	63	Guide Pin
9	Cap-Shift Ring	34	Oil Seal	64	Seal Bushing
10	Adjusting Screw	35	Roller (Bearing)	65	Back-up Ring
11	Cap-Adjusting Screw	36	Clutch	66	"O" Ring
12	Knob-Adjusting Screw	37	Expansion Plug	67	Cover Plate
13	Lock pin	38	Retaining Ring	68	Diaphragm
14	Insert	39	"O" Ring (Relief Valve)	69	Nameplate & Data Plate
15	Gasket-Cap	40	"O" Ring (Shift Ring)	71	Diaphragm Head
16	Stroke Adjusting Scale	41	"O" Ring (Air Bleed)	72	Diaphragm Plate
18	Arm Index	43	Pipe Plug	73	Body Check Valve
19	Hub Index	44	Pipe Plug	74	Seat Check Valve
20	Spring	46	Set Screw	75	Guide Half Check Valve
21	Roller	48	Locking Screw	76	Retainer Check Valve
22	Roller Pin	49	Hex Soc. HD. Bolt	77	Ball Check Valve
23	Air Escape Shaft	50	Hex. Soc. HD. Bolt	78	"O" Ring Check Valve
24	Body-Replenishing Valve	51	Cover Plate Bolt	79	Adapter
25	Stem	52	Diaphragm Head Bolt	80	Gear Reducer
26	Spring Retainer	53	Hex Soc. HD. Bolt	81	Motor
27	Spring	54	Rear Adapter Bolt	85	Motor Key
				86	Insert

Note: Items 24, 25, 26, 27, 28 (Replenishing Valve) - Available As Assembly Only
Item 18, 19, 21, 22, 36 (Air Index Arm) - Available As Assembly Only

Parts List Cyclophragm 5710 Pump Model
Reference Drawings 073-021778 and 073-021778H

Part No.	Description	Part No.	Description	Part No.	Description	Part No.	Description
1	Pump Housing	24	Body (replenishing Valve)	49	Hex Soc. HD. Bolt (Ret. Ring)	74	Seat Check Valve
2	Gasket	25	Stem	50	Hex Soc. HD. Bolt (Cap Adj. Screw)	75	Guide Half Check V.
3	Washer	26	Spring Retainer	51	Cover Plate Bolt (Cover Plate)	76	Retainer Check Valve
4	Lock Nut	27	Spring (replen. valve)	52	Diaphragm head bolt	77	Ball Check Valve
5	Key (Drive Shaft)	30	Plug	53	Screw soc. HD. cap	78	"O" Ring Check valve
6	Shift Ring	31	Diaphragm Plate	54	Nose Plug	79	Adapter
7	Reaction Ring	32	Bearing-Cup	55	Drive Screw	80	Gear Reducer
8	Retaining Ring (Shift R.)	33	Bearing-Cone	56	"O" ring (nose plug)	81	Motor
9	Cap-Shift Ring	34	Oil Seal	59	Bushing (air vent)	82	"O" Ring (relief valve)
10	Adjusting Screw	35	Roller (Shift Ring)	60	Drive Shaft	83	Seat (Relief Valve)
11	Cap-Adjusting Screw	36	Clutch	61	Plunger	84	Diaphragm Plate ass'y
12	Knob-Adjusting Screw	37	Tail Plug	62	Plunger Spring	85	Diaphragm Plate ass'y
13	Lock Pin	38	Retaining Ring (seal, bush)	63	Guide Pin	86	"O" ring (air escape shaft)
14	Insert	39	"O" Ring, Plug	64	Seal Bushing	87	Ball, Anti-rotation
15	Gasket-Cap	40	"O" Ring (shift ring)	65	Back-up Ring	88	End Connection
16	Stroke Adjusting Scale	41	"O" Ring (relief v.)	66	"O" Ring (seal bushing)	89	Body (2" Check Valve)
17	Washer (Tail Plug)	42	Relief Valve	67	Cover Plate	90	"O" Ring (2" check valve)
18	Arm Index	43	Pipe Plug (air vent)	68	Diaphragm	91	Motor Key
19	Hub Index	44	Pipe Plug (drain or fill)	69	Nameplate & Dataplate	92	Insert
20	Spring (Index)	45	Screw, Pan Head (relief valve)	70	Spring (nose plug)	93	Pipe Plug
21	Roller (Index)	46	Set Screw (Knob)	71	Diaphragm Head	94	Warning Label
22	Roller Pin	47	Rear Adapter Bolt	72	Diaphragm Plate	95	Lock nut
23	Air Escape Shaft	48	Set Screw (adj. Screw)	73	Body Check Valve		

NOTE: Items 18,19,21,22,26 (Air Release Index Arm)

Available As Assembly Only

Items 3,4,24,25,26,27 (Replenishing Valve)

Available As Assembly Only

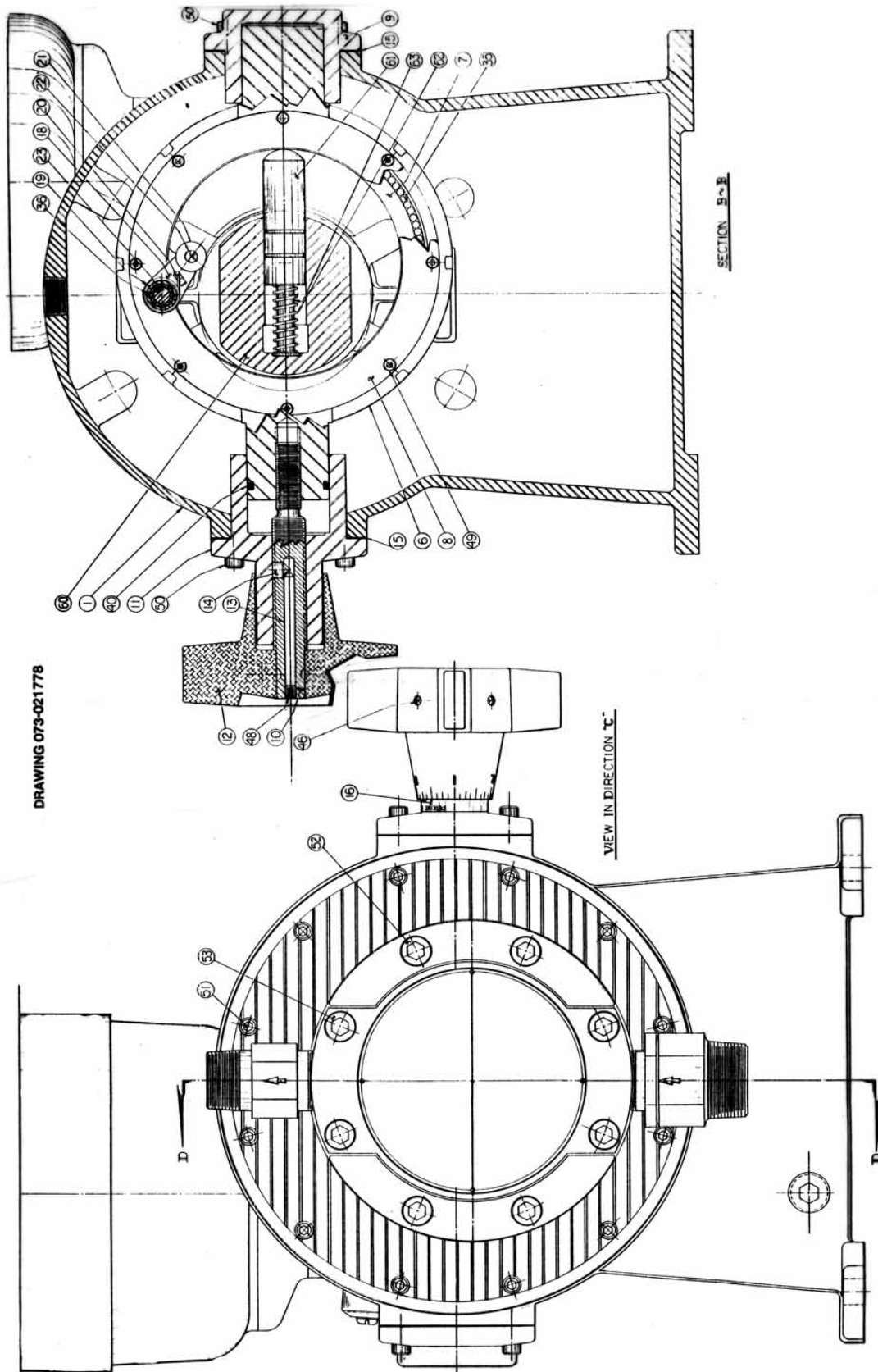

Operation & Maintenance Instructions ■ 5700 Series: 5710, 5720, 5730

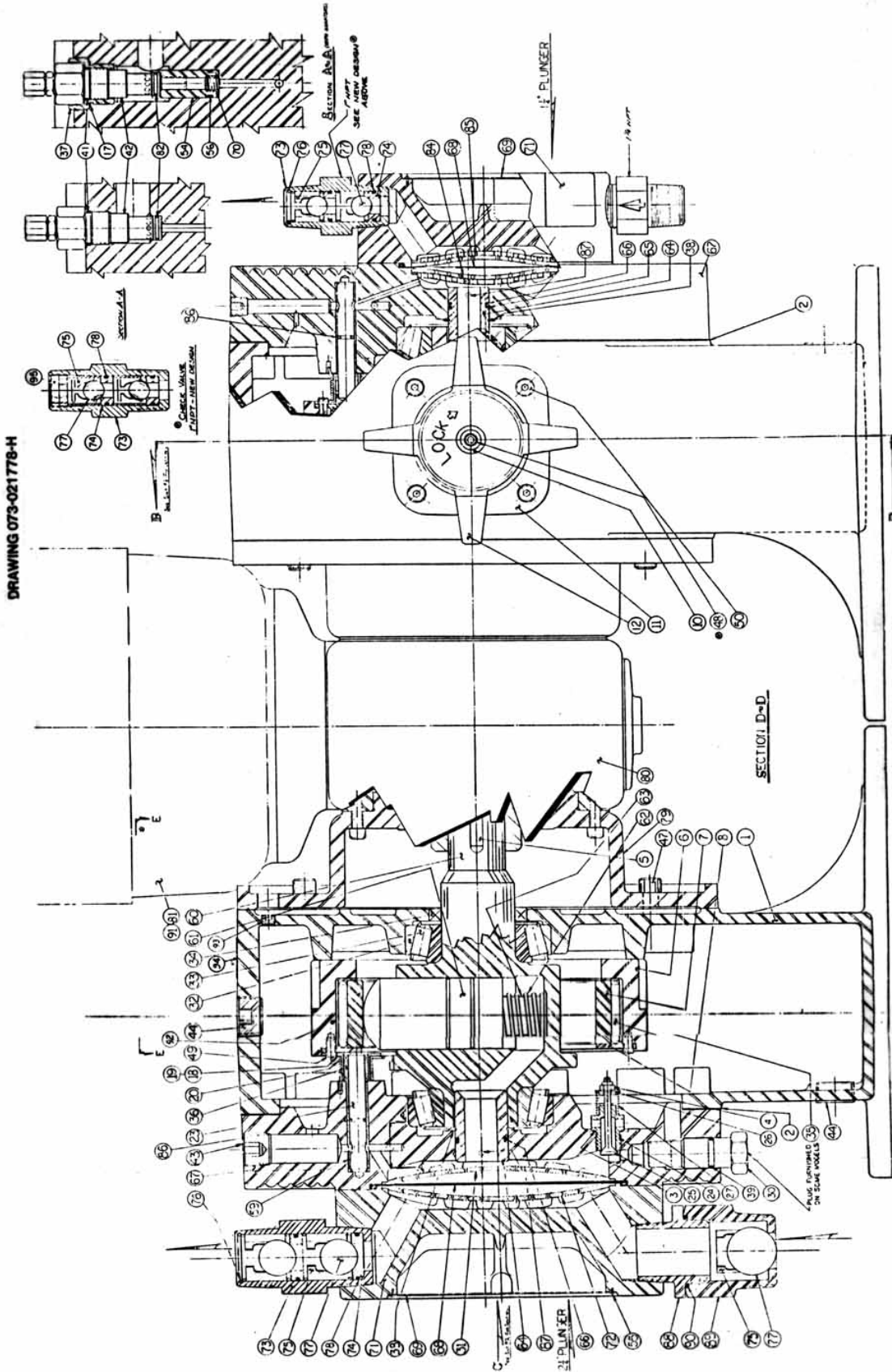

Fixturing Tools for 5700 Series Pumps

Centering fixtures for the 5700 Series pumps are invaluable in pump reassembly. This fixture positions the shift ring concentric to the drive shaft to allow proper recalibration of capacity adjustment "O" point.

<u>Model</u>	<u>Centering Fixture Part Number</u>
5700	TX34017
5710	Y019859
5720	TX34018
5730	TX34019

A seal bushing insertion tool is available for the 5700 model. The bushing has an o-ring and Teflon seal ring that can be damaged on reassembly if not done properly. The insertion tool allows an even application of pressure as the bushing is assembled, reducing the chance of seal ring damage.

<u>Model</u>	<u>Insertion Tool Part Number</u>
5700	260303

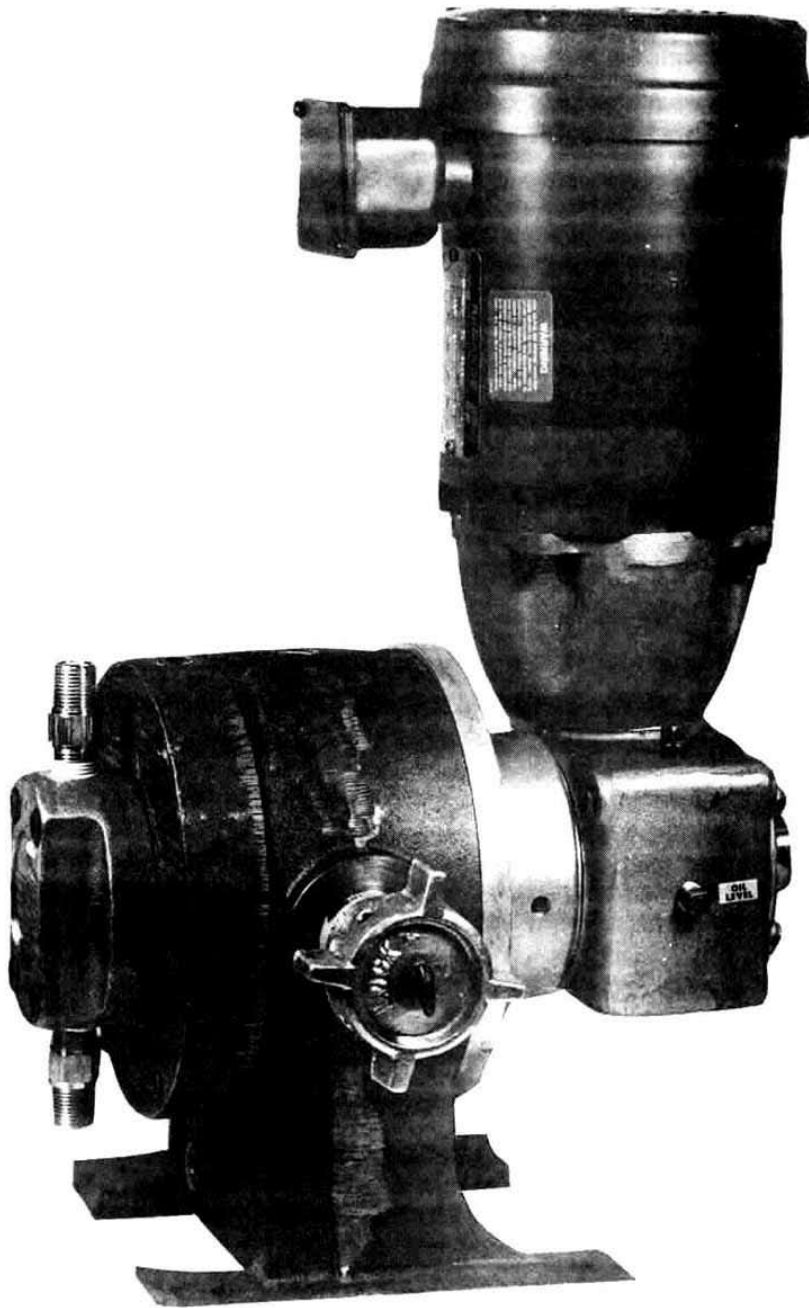

The complete Model Number and Serial No. of this Pump identifies its Size, Speed and Materials of Construction. Always furnish Model Number appearing on Pump Nameplate when ordering parts.

NOTE: If Model Number designation does not appear on this Parts List, order by Part Name and Reference Number, plus complete Pump Model Number and Serial No.

5	7	1							
----------	----------	----------	--	--	--	--	--	--	--

PRODUCT CODE

LIQUID ENDS

PLUNGER DIAMETER

MOTOR

GEAR REDUCER

SPM

LIQ. END MATERIALS

CAPACITY ADJUSTMENT

- 1. Simplex
- 2. Duplex

- 1. 1-3/16"
- 2. 1-5/8"
- 3. 1-3/16" & 1-5/8"

- 1. 1-1/2 Hp
- 3. 1 Hp
- 4. 1-1/2 Hp

- 1. 1-3/4
- 2. 2
- 3. 2-1/2

- 1. 58
- 2. 88
- 3. 117
- 4. 175

- 3. 31 SS
- 4. Carp. #20
- 5. Hastel-loy C
- 6. H₂SO₄
- 7. Polypro.
- 8. Special

- 1. Manual
- 2. Pneu. w/o Signal Trim
- 3. Electric
- 7. Pneu w/ Signal Trim
- 9. Special

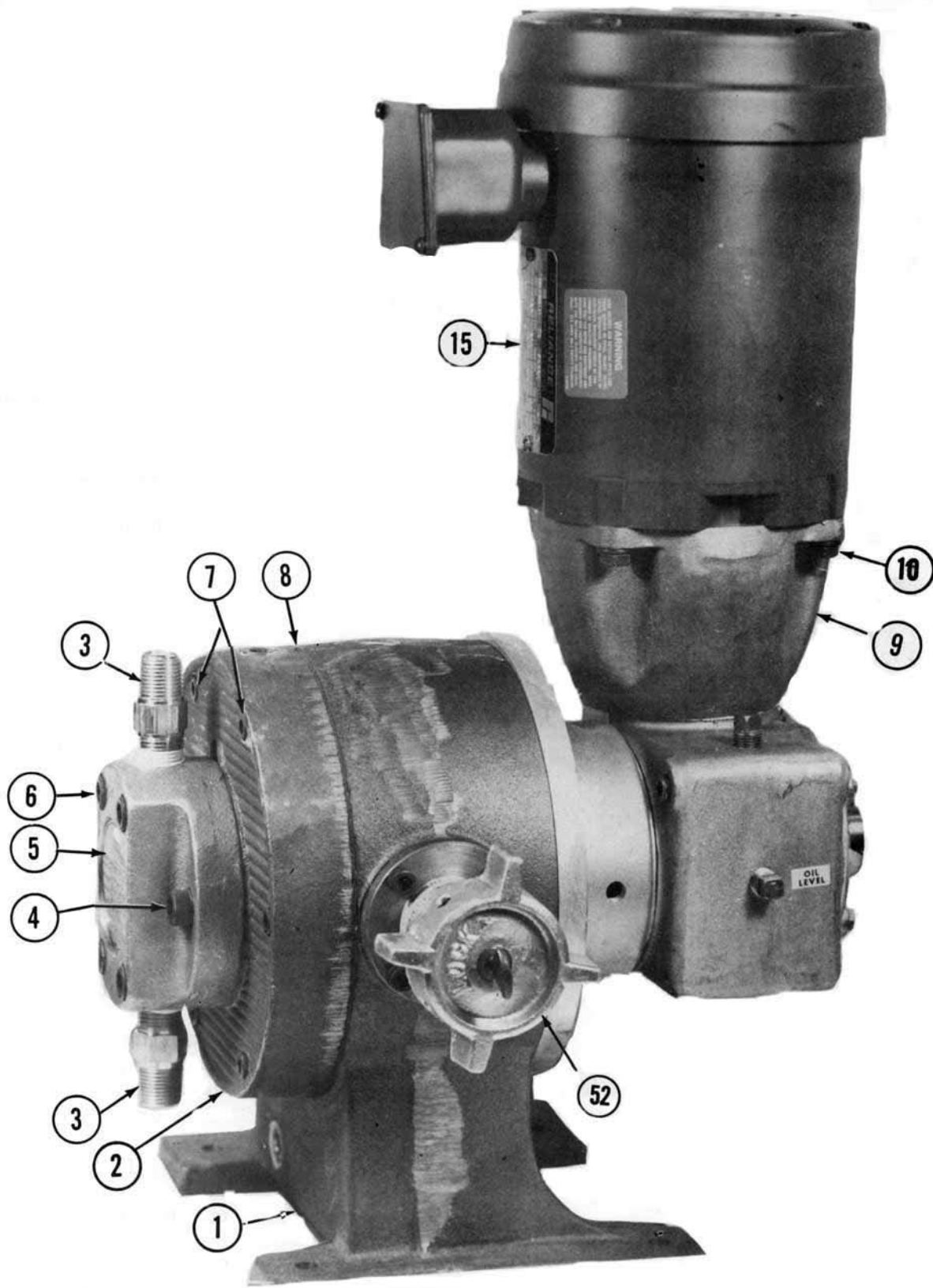

Figure 1 - Complete Pump Assembly

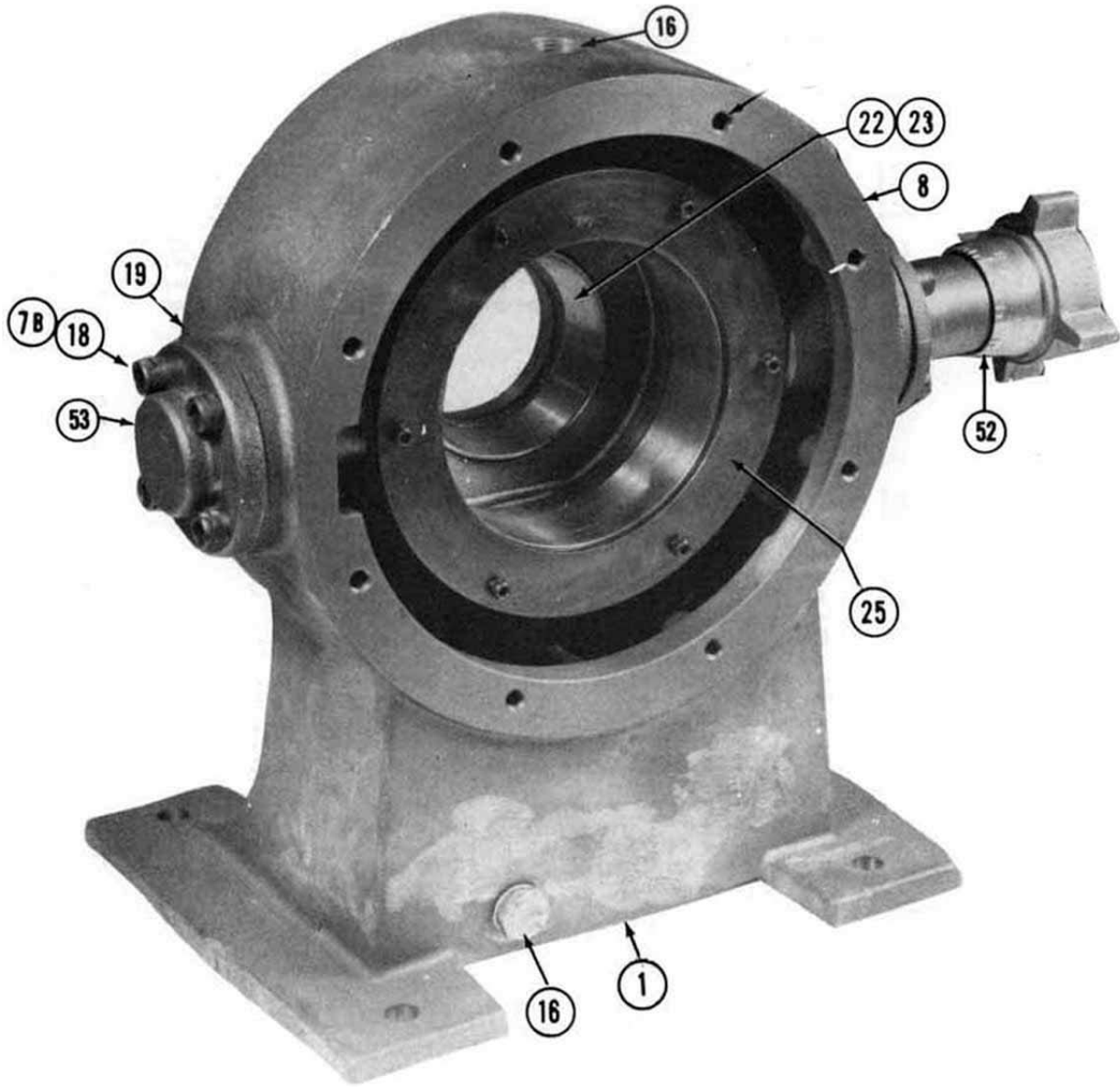

Figure 2 - Pump Housing with Shift Ring Assembly

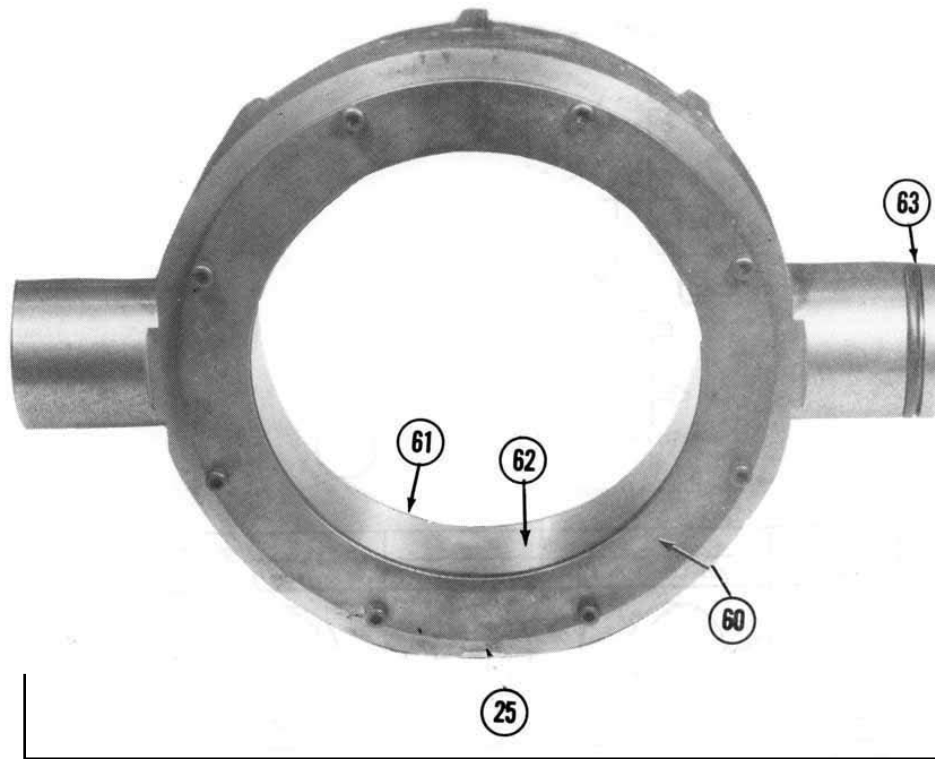

Figure 3 - Shift Ring Assembly

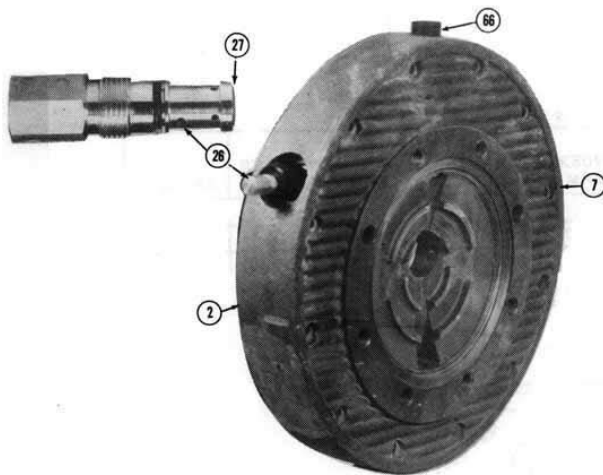

Figure 4 - Cover Plate and Relief Valve Assembly

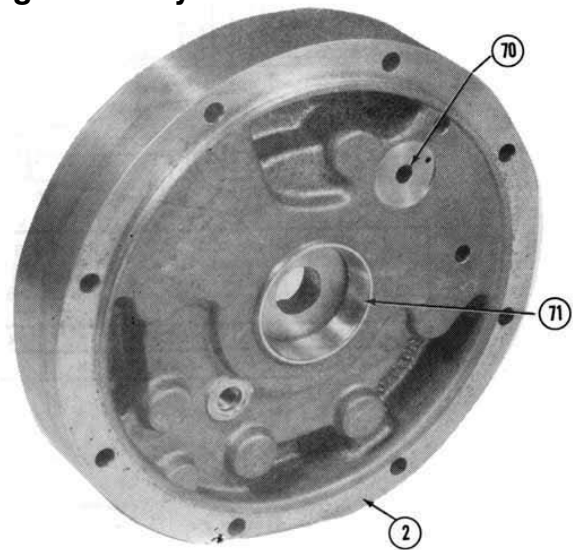

Figure 5 - Cover Plate Assembly

Digits 4 & 5
571X-XX-XXXX

Basic Parts - Simplex
See Figures 1, 2, 3, 4, 5

Select Numbers Corresponding to Nameplate Model No.

Ref. No.	Part Name	Part No.	Ref. No.	Part Name	Part No.
1	Pump Housing	Y060090	1	Pump Housing	Y060090
2	Cover Plate Assy.	Y061403-07	2	Cover Plate Assy.	Y061402-07
5b	Nameplate	Y102901	5b	Nameplate	Y102900
7a	5/16"-18 Screw	Y302294	7a	5/16"-18 Screw	Y302294
7b	5/16" Washer	Y933941	7b	5/16" Washer	Y933941
8a	Gasket	Y019384-01	8a	Gasket	Y019384-01
8b	Gasket	Y019384-02	8b	Gasket	Y019384-02
8c	Gasket	Y019384-03	8c	Gasket	Y019384-03
8d	Gasket	Y019384-04	8d	Gasket	Y019384-04
8e	Gasket	Y019384-05	8e	Gasket	Y019384-05
16	½" Pipe Plug	Y302288	16	½" Pipe Plug	Y302288
18	5/16" Socket Head Screw	Y302295	18	5/16" Socket Head Screw	Y302295
19	Gasket	Y933920	19	Gasket	Y933920
22	Bearing	Y302276	22	Bearing	Y302276
23	Seal	Y302278	23	Seal	Y302278
25	Shift Ring (includes #60 thru #63)	Y933955	25	Shift Ring (includes #60 thru #63)	Y933955
26a	Relief Valve 50-200	Y945733-01-07	26a	Relief Valve50-200	Y945733-01-07
26b	Relief Valve 100-900	Y945733-02-07	26b	Relief Valve100-900	Y945733-02-07
26c	Relief Valve 800-400	Y945733-03-07	26c	Relief Valve 800-400	Y945733-03-07
◆26d	O-Ring	Y302953	◆26d	O-Ring	Y302953
27	Washer	Y945381	27	Washer	Y945381
	Reaction Ring	Y933916		Reaction Ring	Y933916
	Retaining Ring	Y019385		Retaining Ring	Y019385
	Roller (inside) 74 req'd	Y302279		Roller (inside) 74 req'd	Y302279
63	O-Ring	413-0568-214	◆63	O-Ring	413-0568-214
64	Bolts	Y300380	64	Bolts	Y300380
66	3/8" Pipe Plug	Y302589	66	3/8" Pipe Plug	Y302589
70	Plug	Y302281	70	Plug	Y302281
71	Cup Brg. (including in #2)	Y302276	71	Cup Brg. (included in #2)	Y302276

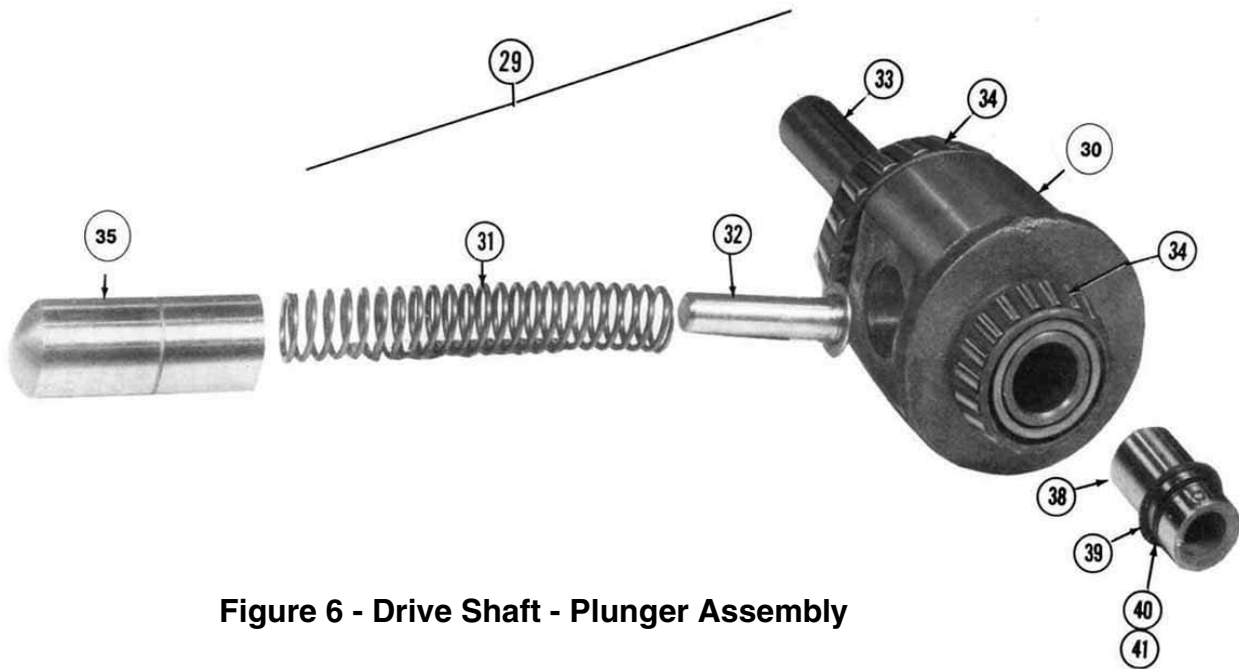

Figure 6 - Drive Shaft - Plunger Assembly

Digit 5
571X-XX-XXXX

Drive Shaft - Plunger Assembly

Ref. No.	Part Name	Part No. 19/32"	Part No. 1-1/16"
29	Drive Shaft-Plunger Assy.	Y934080-1	Y934080-03
30	Shaft	Y041803-03	Y041803-01
◆31	Spring	Y933915-03	Y933915-01
32	Pin	Y933943-03	Y933943-01
33	Key	Y933912	Y933912
34	Bearing	Y302277	Y302277
35	Plunger	Y933914-03	Y933914-01
38	Seal Bushing	Y933947	Y933913
	Seal Ring	Y948259	Y302302
	Retaining Ring	Y302305	Y302301
	O-Ring (2)	Y300773	Y302304

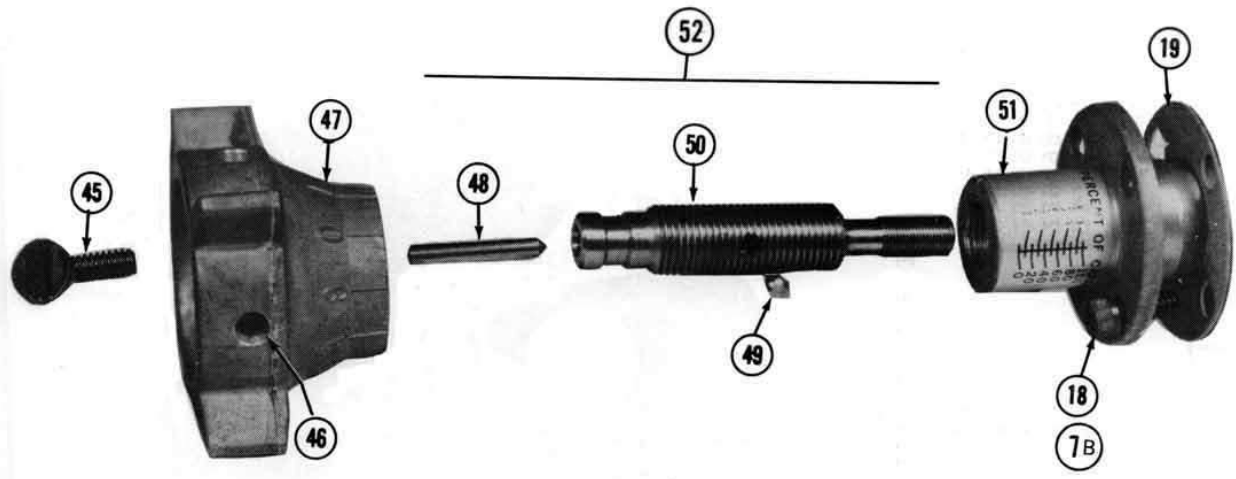

Figure 7 - Capacity Adjustment

Digit 10
571X-XX-XXXX

Drive Shaft - Capacity Adjustment
Reference No. 52 Micrometer - Y934084

Ref. No.	Part Name	Part No.
45	5/16-18 Screw	Y305061
46	1/4-20 Set Screw (2)	Y302290
47	Knob	Y041807
48	Lockpin	Y933918
49	Insert	Y933919
50	Adjustment Screw	Y933917
51A	Adjustment Screw Cap	Y019388
51B	Scale	Y952259

Check Valve

Head Material 1/2" Suction or Discharge

Ref No.	Part Name	316SS Part No.	C20 Part No.	Hast C Part No.	H ₂ SO ₄ Part No.
3	Complete Check*	Y933958-91	Y999958-84	Y933958-82	Y933958-01
80	Body	Y933945-91	Y933945-84	Y933945-82	Y933945-84
◆81	Seat (2 req'd)	Y933946-91	Y933946-84	Y933946-82	Y933946-84
◆82	O-Ring (4 req'd)	Y948548-01	Y948548-01	Y948548-01	Y948548-01
◆83	Guide (4 req'd)	Y019395-91	Y019395-84	Y019395-82	Y019395-84
84	Retainer	Y933948-91	Y933948-82	Y933948-82	Y933948-82
85	Ball (2 req'd)	Y933950-91	Y933950-82	Y933950-82	Y933950-81

Check Valve

Head Material 3/4" Suction or Discharge

Ref No.	Part Name	316SS Part No.	C20 Part No.	Hast C Part No.	H ₂ SO ₄ Part No.
3	Complete Check*	Y933959-91	Y933959-84	Y933959-82	Y933959-01
80	Body	Y933937-91	Y933937-84	Y933937-82	Y933937-84
◆81	Seat (2 req'd)	Y933938-91	Y933938-84	Y933938-82	Y933938-84
◆82	O-Ring (2 req'd)	Y948548-02	Y948548-02	Y948548-02	Y948548-02
◆83	Guide (4 req'd)	Y019393-91	Y019393-84	Y019393-82	Y019393-84
84	Retainer	Y933939-91	Y933939-82	Y933939-82	Y933939-82
85	Ball (2 req'd)	Y933940-91	Y933940-82	Y933940-82	Y933940-81

Check Valve

Head Material Polypropylene (Not Shown)

Ref No.	Part Name 316SS	Suction	- 1/2" -	Discharge
3	Complete Check**	Y948271		Y948270
107	Insert	Y948254		Y948254
108	Upper Body	Y948253		Y948253
109	Lower Body	Y948252		Y948252
110	Clamp	Y948255		Y948255
◆111	O-Ring (2 req'd)	Y305066		Y305066
112	Ball	Y303766		Y303766

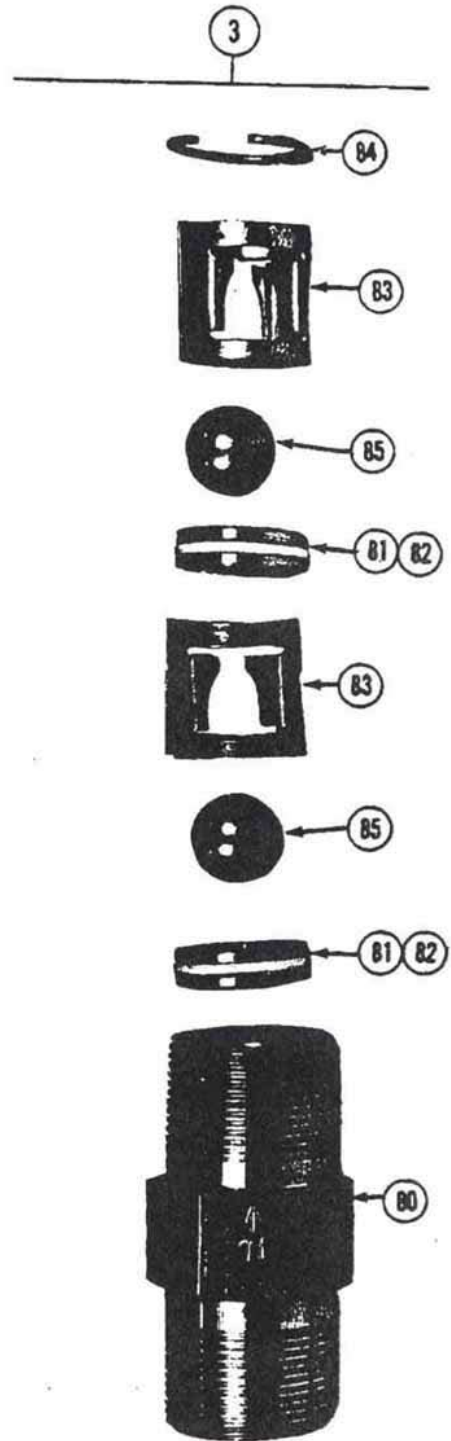

Figure 8 - Check Valve Assembly

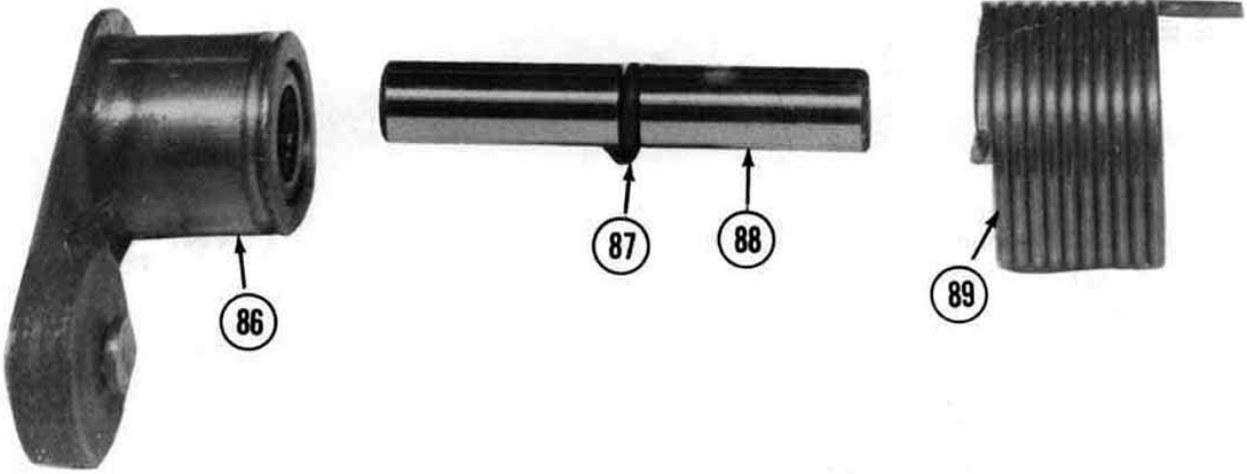

Figure 9 - Air Vent Assembly
(see Fig. 10 for installation orientation)

Digit 10
571X-XX-XXXX

Air Vent
Y934083-01

Ref. No.	Part Name	Part No.
86	Index Arm Assembly	Y019390
◆87	O-Ring	Y302285
88	Shaft	Y933926
89	Spring	Y933923

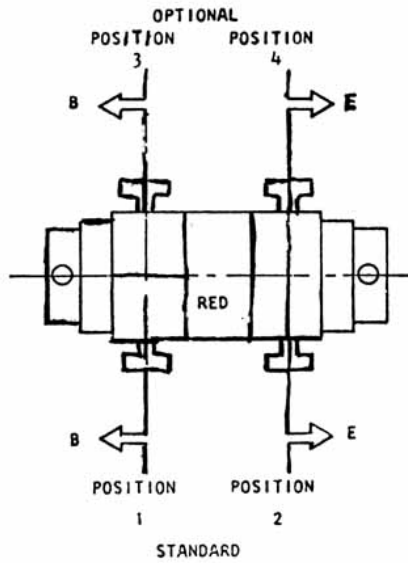
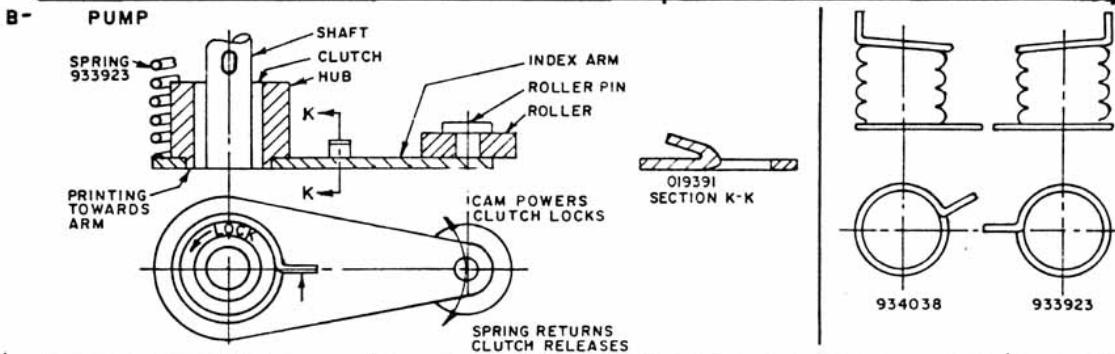
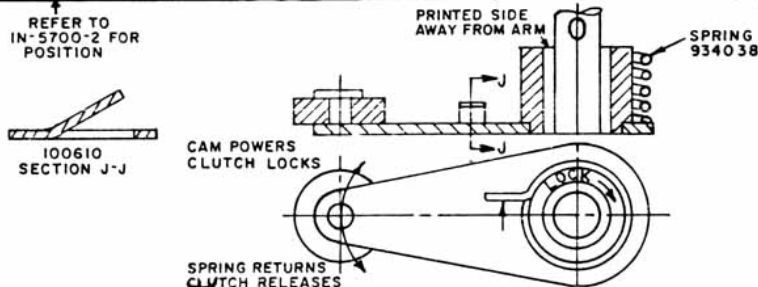

Figure 10 - Air Vent Installation Orientation

PUMP MODEL	STANDARD		OPTIONAL	
	POSITION 1	POSITION 2	POSITION 3	POSITION 4
5710 (B)	B-B Y 019390	E-E Y 102399	B-B Y 102399	E-E Y 019390



ASSEM. PT. NO.	POSITION			CLUTCH	PRINTED SIDE		INDEX ARM	HUB	ROLLER	ROLLER PIN	SPRING
	1	2	3		TOWARD ARM	AWAY FROM ARM					
B 102399	X	X		302280		X	100610	933922	933924	933925	934038
B 019390	X		X	302280	X		019391	933922	933922	933925	933923



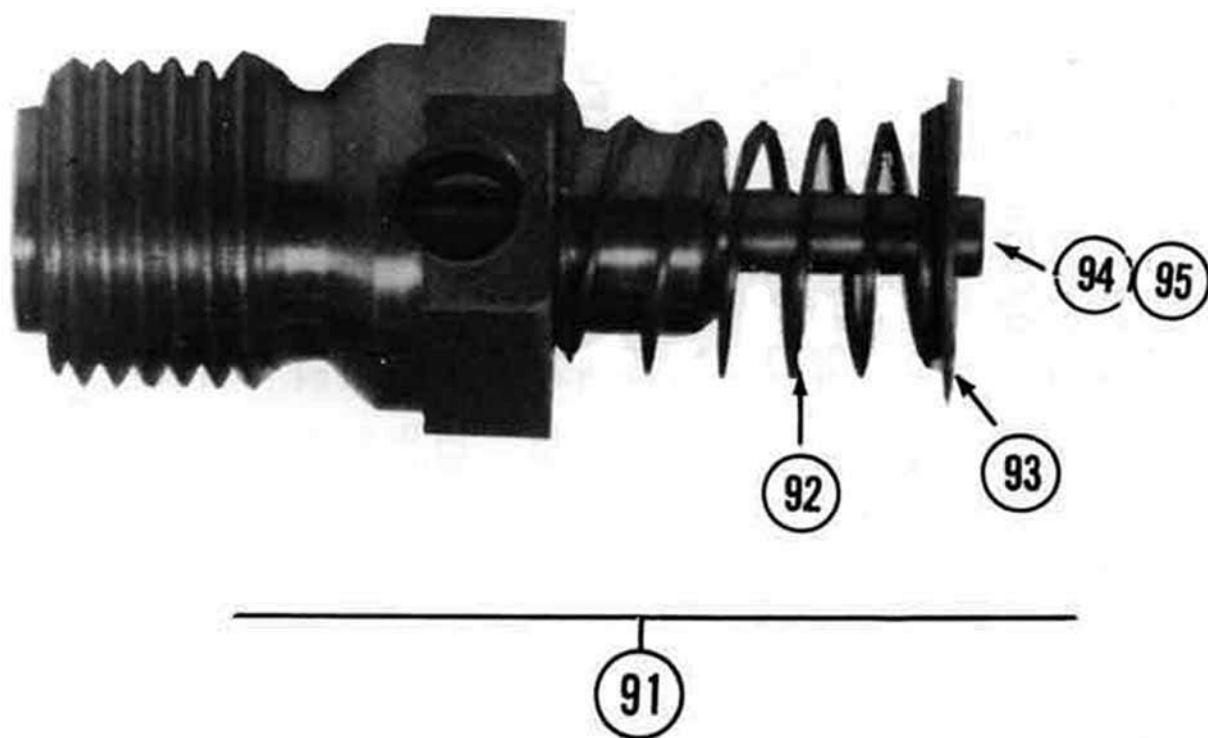

Figure 11 - Oil Replenishing Valve

Oil Replenishing Valve

Ref. No.	Part Name	Part No.
91	Replenishing Assembly (91a-95)	Y933956
91a	Body	Y933927
91b	Washer	Y933941
92	Spring	Y933930
93	Retainer	Y933929
94	Stem	Y933928
◆95	Truarc Ring	417-0105-003

◆Recommended spare parts sets, Model 5710 Pump

These are the recommended spare parts for one year's operation of a simplex pump. For multiple pump orders, one set for each plunger diameter and liquid end material for each 2 or 3 pumps will be satisfactory.

Each set includes:

- 1 – Oil Seal
- 1 - Set of 5 “O” Rings
- 1 – Plunger spring
- 1 – Diaphragm
- 4 – Valve seats
- 4 – Valve guides
- 2 – Valve retainers
- 4 – Valve ball checks
- 4 – Valve “O” Rings
- 1 – Back up ring

NOTE: Recommended spare parts apply only if furnished as part of original equipment.

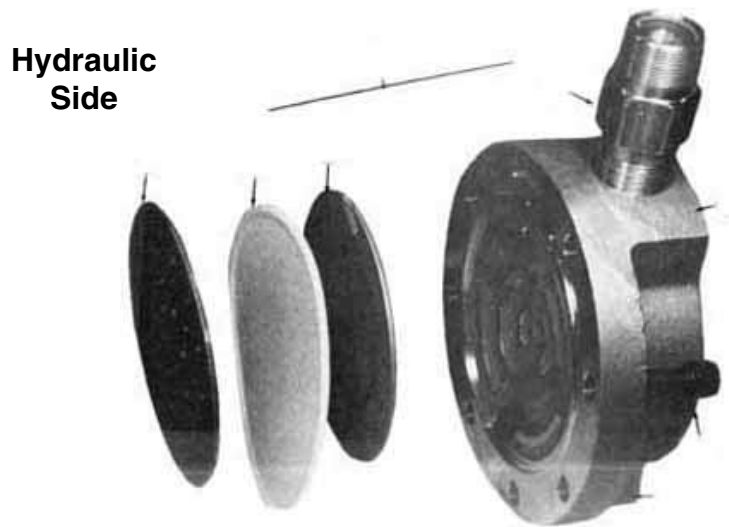

Figure 12 - Head Assembly

Metal Head - 19/32" Plunger

Ref No.	Part Name	Qty.	316SS Part No.	C20 Part No.	Hast C Part No.	H ₂ SO ₄ Part No.
11	Complete Assembly*	1	Y940858-03	Y940858-04	Y940858-05	Y940858-06
4	Short Bolt	4	4170053418	4170053418	4170053418	4170053418
5	Head	1	Y060096-91	Y060096-84	Y060096-82	Y060096-91
6	Long Bolt	4	4170053427	4170053427	4170053427	4170053427
72	Diaphragm Plate	1	Y041812-79	Y041812-79	Y041812-79	Y041812-79
73	Diaphragm	1	Y933944	Y933944	Y933944	Y933944
74	Diaphragm Plate	1	Y041812-91	Y041812-84	Y041812-82	Y041812-84

Metal Head - 1-1/16" Plunger

Ref No.	Part Name	Qty.	316SS Part No.	C20 Part No.	Hast C Part No.	H ₂ SO ₄ Part No.
11	Complete Assembly*	1	Y934082-03	Y934082-04	Y934082-05	Y934082-06
4	Short Bolt	4	4170053418	4170053418	4170053418	4170053418
5	Head	1	Y043908-91	Y043908-84	Y043908-82	Y043908-91
6	Long Bolt	4	4170053427	4170053427	4170053427	4170053427
72	Diaphragm Plate	1	Y041809-79	Y041809-79	Y041809-79	Y041809-79
73	Diaphragm	1	Y933932	Y933932	Y933932	Y933932
74	Diaphragm Plate	1	Y041809-91	Y041809-84	Y041809-82	Y041809-84

Metal Head - High Suction Lift - 1-1/16" Plunger

Ref. No.	Part Name	Qty.	316 SS Part No.	C20 Part No.	H ₂ SO ₄ Part No.
11	Complete Assembly*	1	Y934082-33	Y934082-34	Y934082-36
122	Head	1	Y061210-91	Y061210-84	Y061210-91
◆115	Spring	1	Y942067-82	Y942067-82	Y942067-82
◆116	Seat	1	Y942071-01	Y942071-01	Y942071-01
◆117	Spring	1	Y942066-82	Y942066-82	Y942066-82
◆118	Seat	1	Y942072-01	Y942072-01	Y942072-01
119	Pad	1	Y942959-02	Y942959-02	Y942959-02

**Assembly includes items 115-119, 122 & 123

◆Recommended spare parts.

Figure 13 - High Suction Lift Head Assembly

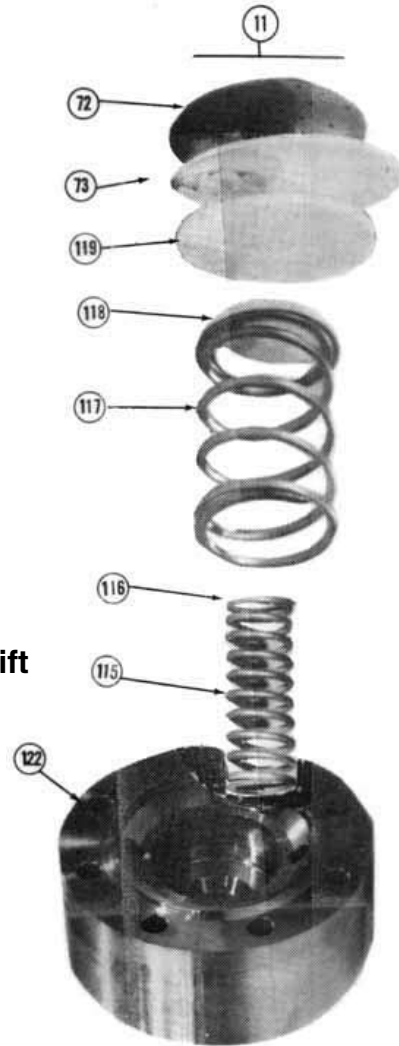

Ref. No. 195 Double Diaphragm Simplex
Y959596-01 (Not Shown)

Ref. No.	Part Name	Part No.
180	Head	Y041831
181	Diaphragm	Y933944
182	Ball	Y303036
183	Spring	Y934001
184	Set Screw	Y303037
185	Hex Nut	Y303040
186	Cap Screw	Y302702
187	Elbow	Y305016
188	Nipple	Y303791
189	Coupling	416-1203-001
190	Angle Valve	Y303793
191	Tag	DT-155

Parts Not Shown are for Units Prior to Jan. 1985

Digit 6
571X-XX-XXXX

Digit 8
571X-XX-XXXX

Motors
(See Fig. 1) 56C Frame

Ref. No.	Part Name	Part No.	Field
15	¼ HP 115/230 TEFC	Y938423-01	1
	¼ HP 115/230 XP	Y938423-03	2
	¼ HP 230/460 TEFC	Y938423-17	3
	¼ HP 230/460 XP	Y938423-19	4
15	1/3 HP 115/230 TEFC	Y938423-05	5
	1/3 HP 115/230 XP	Y938423-07	6
	1/3 HP 230/460 TEFC	Y938423-21	7
	1/3 HP 230/460 XP	Y938423-23	8
15	½ HP 115/230 TEFC	Y938423-09	9
	½ HP 115/230 XP	Y938423-11	10
	½ HP 230/460 TEFC	Y938423-25	11
	½ HP 230/460 XP	Y938423-27	12
15	¾ HP 115/230 TEFC	Y938423-13	13
	¾ HP 115/230 XP	Y938423-15	14
	¾ HP 230/460 TEFC	Y938423-29	15
	¾ HP 230/460 XP	Y938423-31	16
15	1 HP 230/460 TEFC	Y938423-33	17
	1 HP 230/460 XP	Y938423-35	18
15	1-1/2 HP 230/460TEFC	Y938423-37	19
	1-1/2 HP 230/460 XP	Y938423-39	20

Speed Reducer
(See Fig. 1 & 14)

Ref. No.	SPM	Part No.
9	58	239499-1
9	88	239499-2
9	117	239499-3
9	175	239499-4
9	233	239499-5

- 10a. 3/8x1 Bolt
- 10b. 3/8h Washers
- 96. Pipe Plug Y305001
- 103. Key 3/16x3/4 Y304643
- 104. Coupling Y304616
- ◆105. Hydraulic oil (not Shown) Y302950

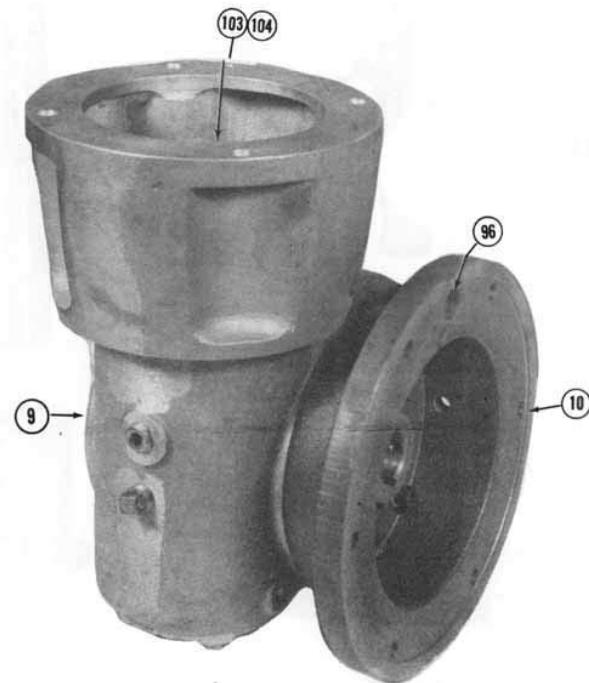

Figure 14 - Speed Reducer

Digit 6

571X-XX-XXXX

Electric
(See Fig. 15)

Ref. No.	Part Name	Part No.
130	Electric Stroke Adjustment	Y946081-01
131	Motor – Actuator	Y946732-01
132	Hex Head Cap Screws	4170052110
133	Motor Frame	Y061432
134	Soc. Head Cap Screws	4170053045
u135	Gasket	Y933977
u136	O- Ring	4130568216
u137	Retaining Ring	Y304487
138	Set Screw	Y304582
140	Drive Adaptor	Y946064
141	Lead Screw (not shown)	Y946065
142	Cap Adjustment Screw	Y102408
143	Lock Washer	4170036672
144	Washer	Y933941
145	Spring Scale Retainer	Y102675
146	Scale	Y946090
147	Set Screw	Y304810
148	Pointer	Y946159
149	Bushing	Y946091
150	Special Screw	Y304524
151	Torsion Spring	Y947122
152	Label	Y949564
153	Relay (Not Shown)	Y946779-01

Pneumatic
(See Fig. 16)

Ref. No.	Part Name	Part No.
154	Pneumatic Actuator Complete	Y934085-01
155	Screw	Y940512
156	Set Collar	4170091075
157	Screw for Pointer	Y940510
158	6/32 Cap Screw	Y302520
159	1/2-13 Cap Screw	Y303159
160	Extension Shift Ring	Y940639
161	Actuator Only	Y941658-01
162	Taper Pin if needed (not shown)	Y303195
163	Backup Ring	Y302615
u164	O-Ring	4130538214
165	Flange Adaptor	Y100694
166	Shift Ring Cap	Y019456
167	Ball	Y302608
168	3/16" dia. Ball	Y302286
169	Replenishing Spring	Y940670
170	Ball Follower	Y934048
171	¼-20 Hex Nut	417022075
172	Thread Seal Washer	Y303160
173	Replenishing Screw	Y940669
u174	O-Ring (air vent)	Y302285
175	¼ - 20x3 Screw	Y305245
176	Stroke Scale	Y939026
177a	Spring (300 lb.)	Y303180
177b	Spring (850 lb)	Y303181
177c	Spring (1600 lb.)	Y303182

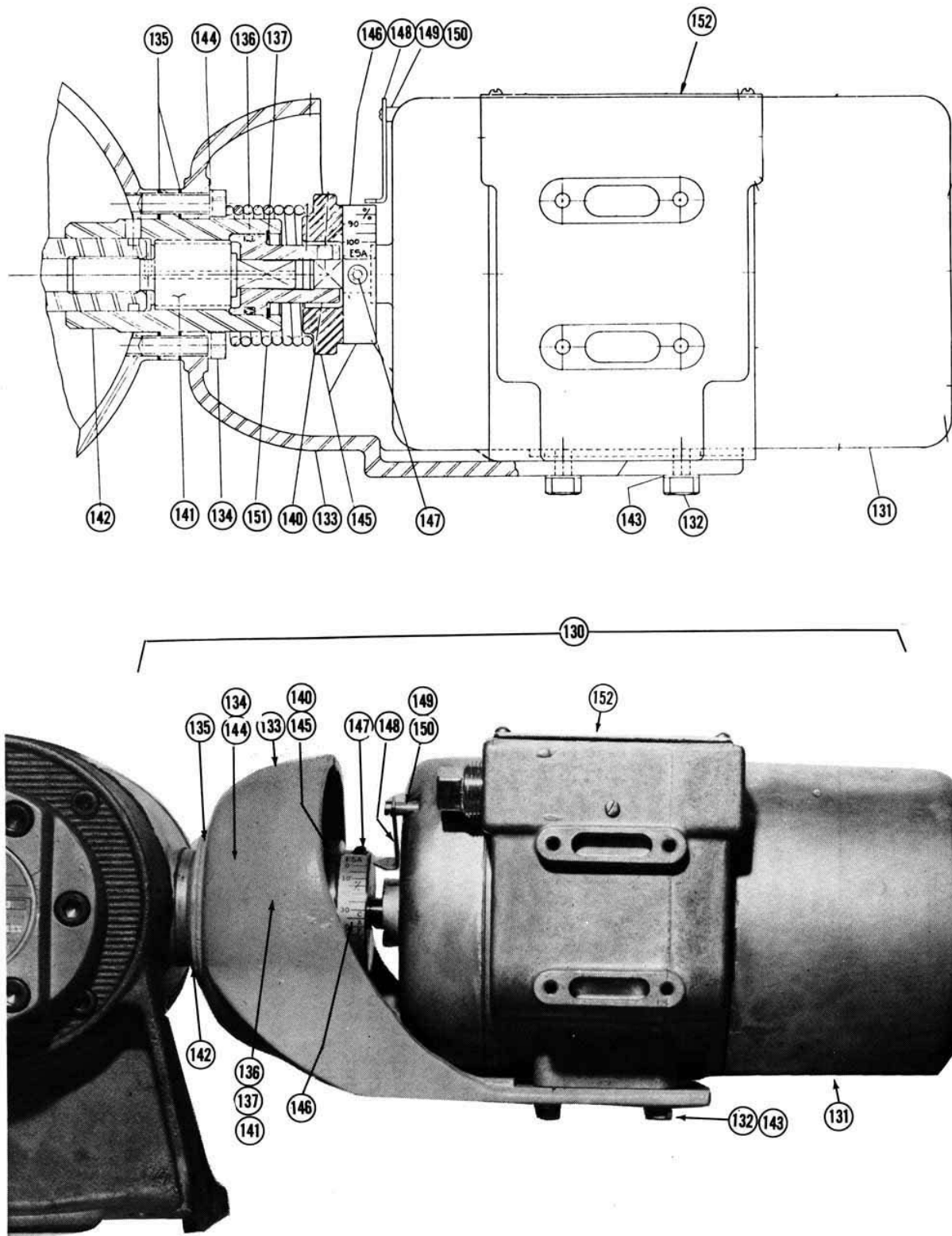

Figure 15 - Electric Capacity Adjustment

**MODEL 5710 PUMP
WITH PNEU. ACTUATOR
DRAWING 071-021847**

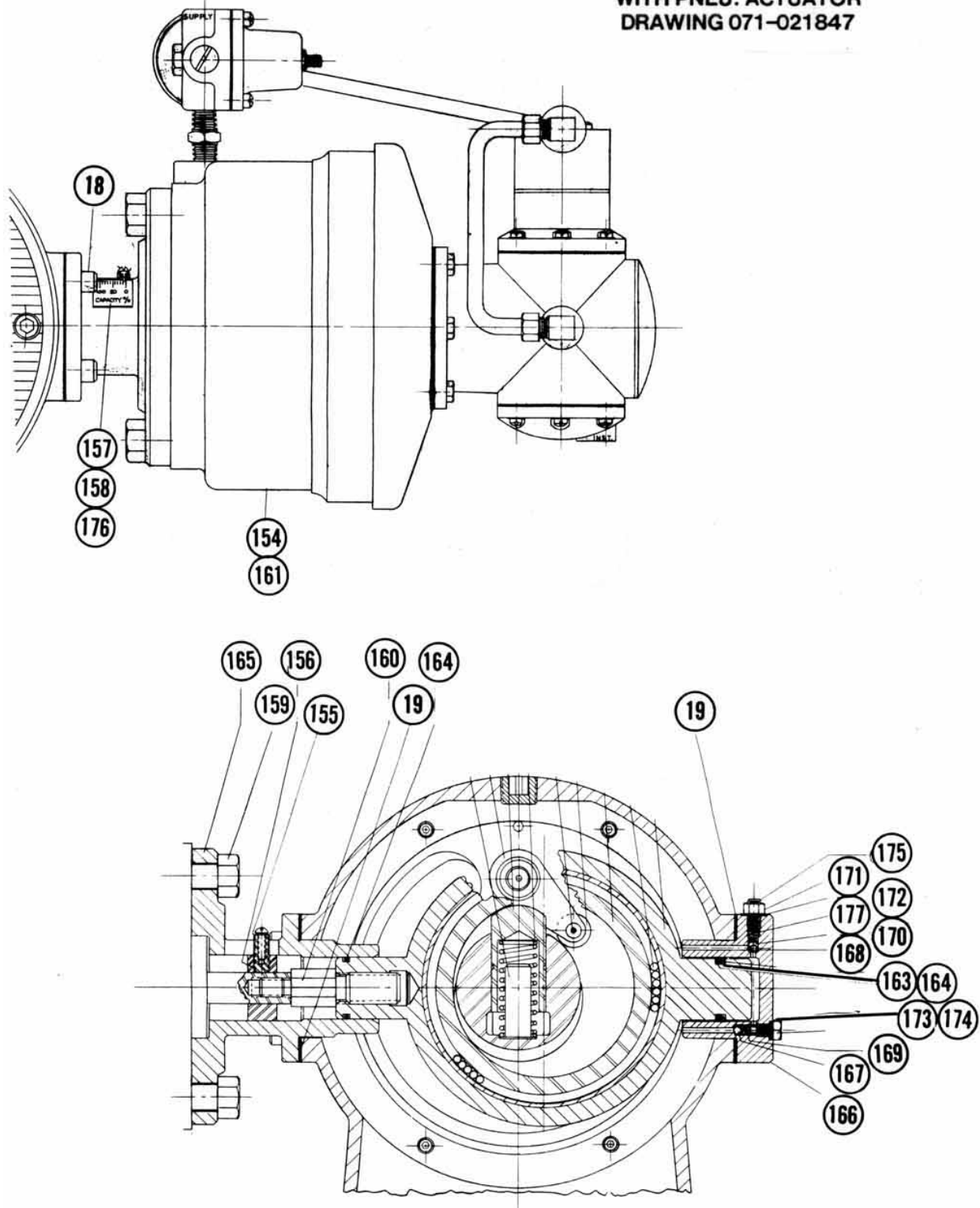
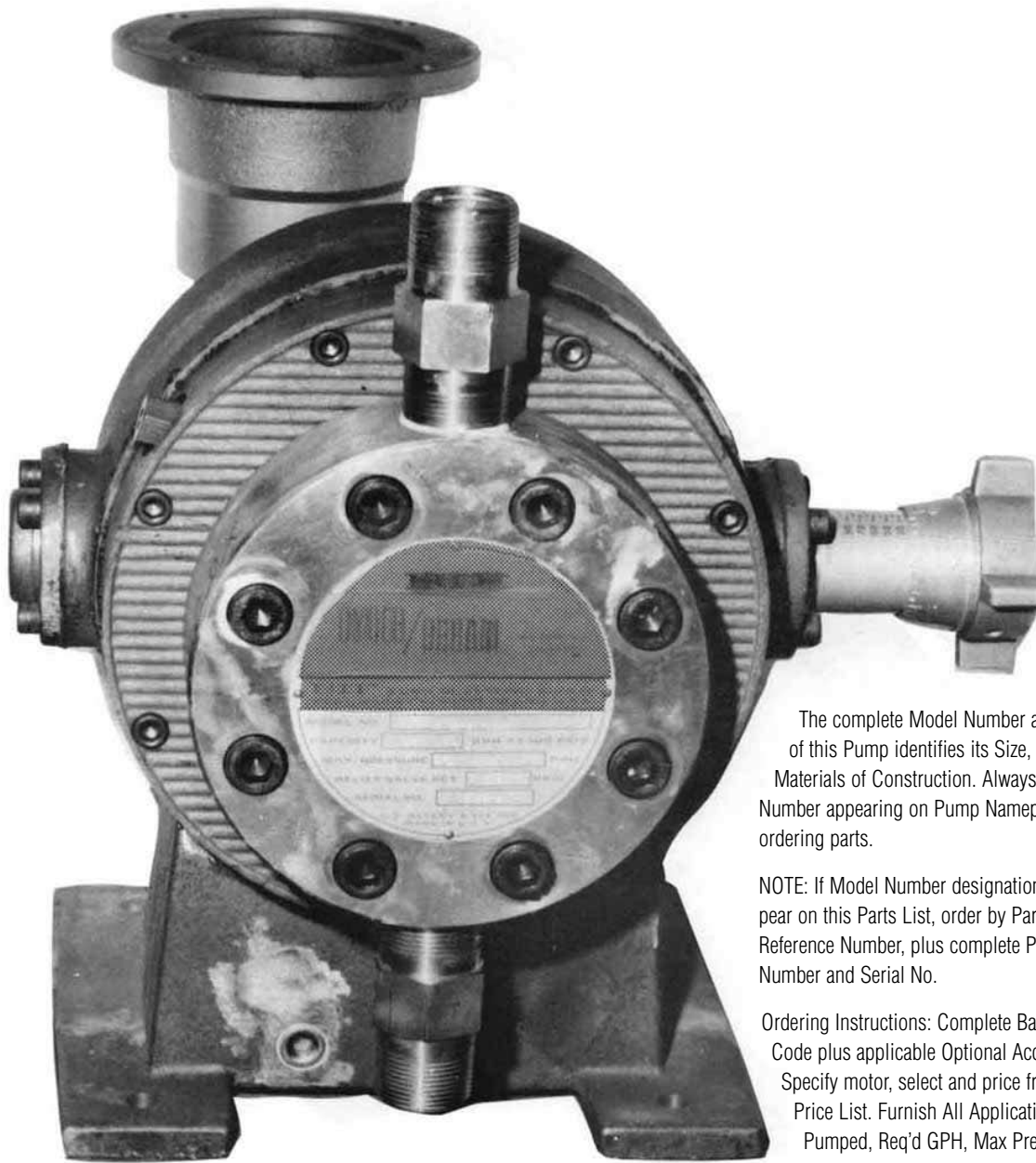

Figure 16 - Pneumatic Capacity Adjustment



The complete Model Number and Serial No. of this Pump identifies its Size, Speed and Materials of Construction. Always furnish Model Number appearing on Pump Nameplate when ordering parts.

NOTE: If Model Number designation does not appear on this Parts List, order by Part Name and Reference Number, plus complete Pump Model Number and Serial No.

Ordering Instructions: Complete Basic Product Code plus applicable Optional Accessories. Specify motor, select and price from Motr Price List. Furnish All Application Data: Fluid Pumped, Req'd GPH, Max Pressure

5	7	2							
----------	----------	----------	--	--	--	--	--	--	--

PRODUCT CODE	LIQUID ENDS	PLUNGER DIAMETER	MOTOR	GEAR REDUCER	SPM	LIQ. END MATERIALS	CAPACITY ADJUSTMENT
	1. Simplex	1. 1-3/16"	1. 1-1/2 Hp	1. 1-3/4	1. 58	3. 31 SS	1. Manual
	2. Duplex	2. 1-5/8"	3. 1 Hp	2. 2	2. 88	4. Carp. #20	2. Pneu. w/o Signal Trim
		3. 1-3/16" & 1-5/8"	4. 1-1/2 Hp	3. 2-1/2	3. 117	5. Hastel-loy C	3. Electric
					4. 175	6. H ₂ SO ₄	7. Pneu w/ Signal Trim
						7. Polypro.	9. Special
						8. Special	

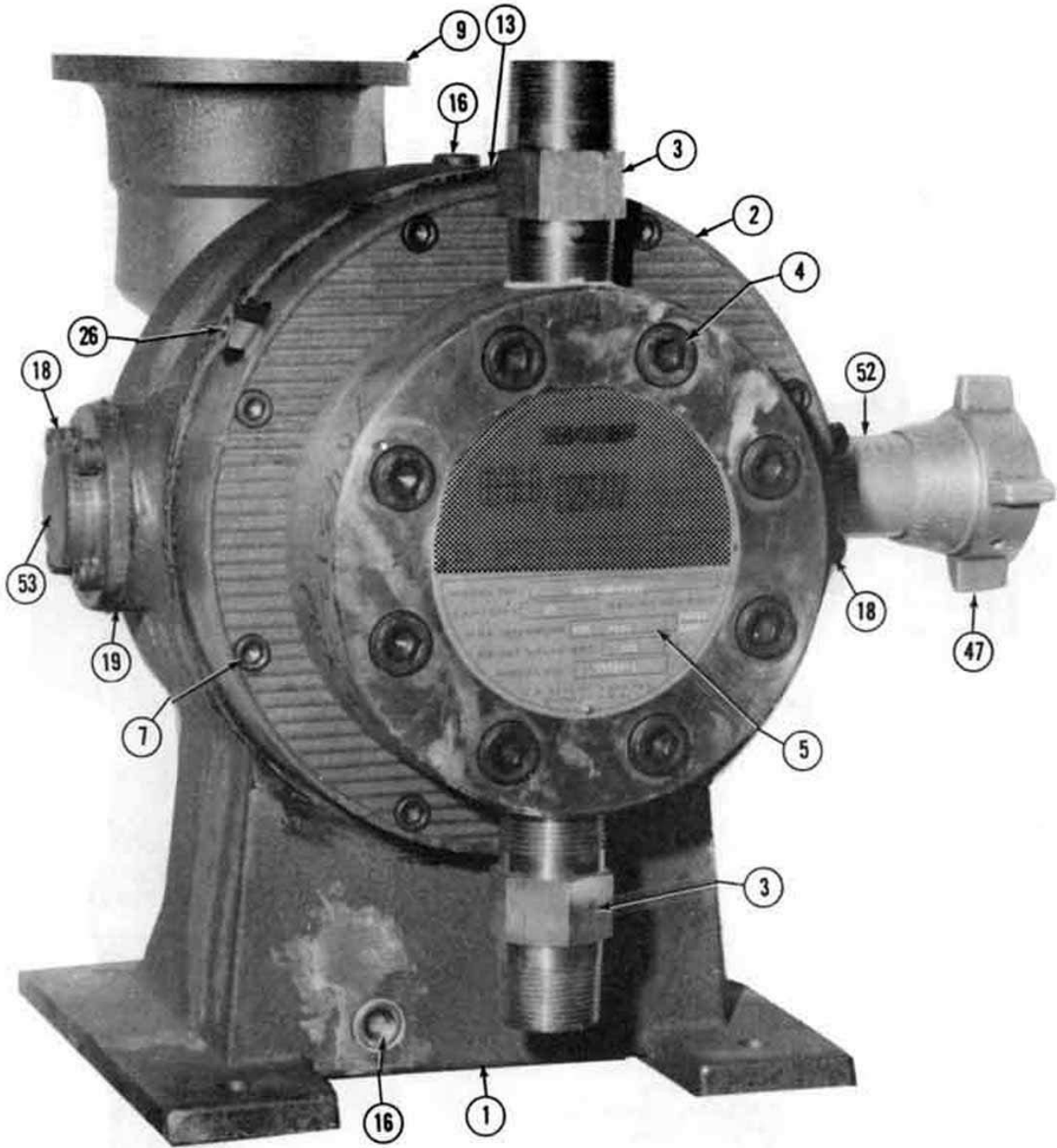

Figure 1 - Complete Pump Assembly

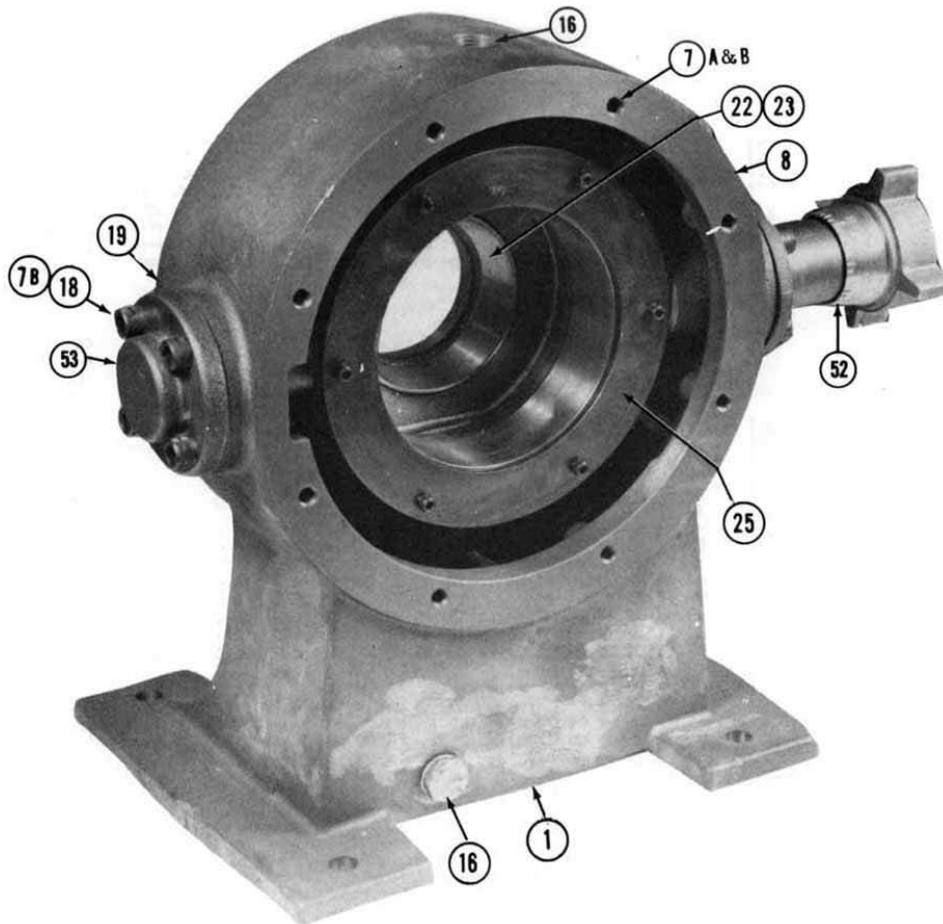

Figure 2 - Pump Housing with Shift Ring Assembly
Figure 16 - Pneumatic Capacity Adjustment
Figure 16 - Pneumatic Capacity Adjustment

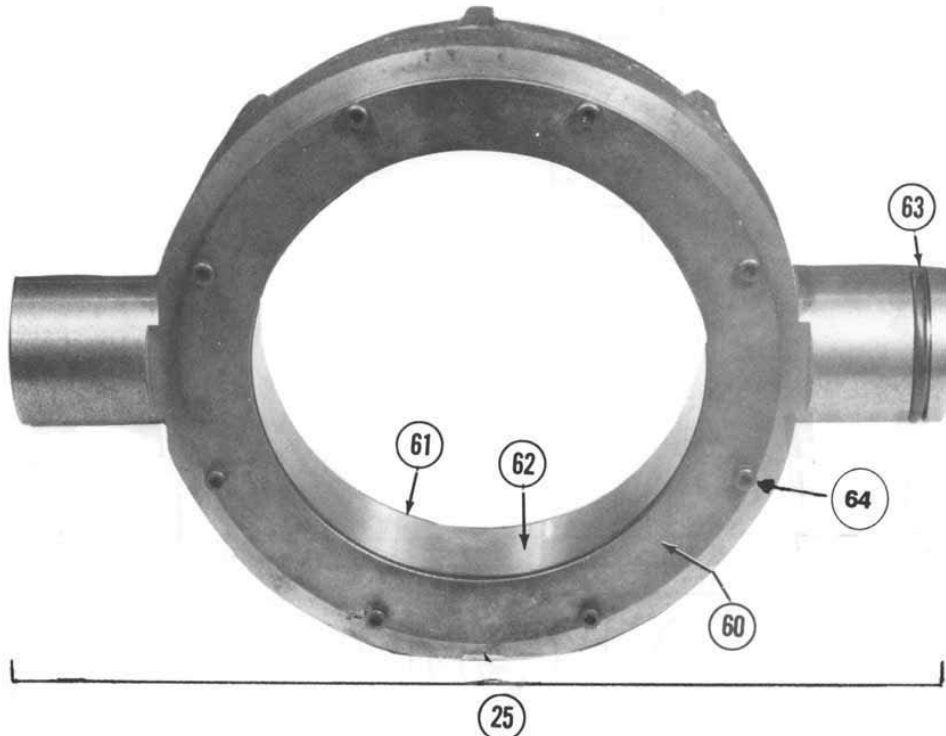

Figure 3 - Shift Ring Assembly

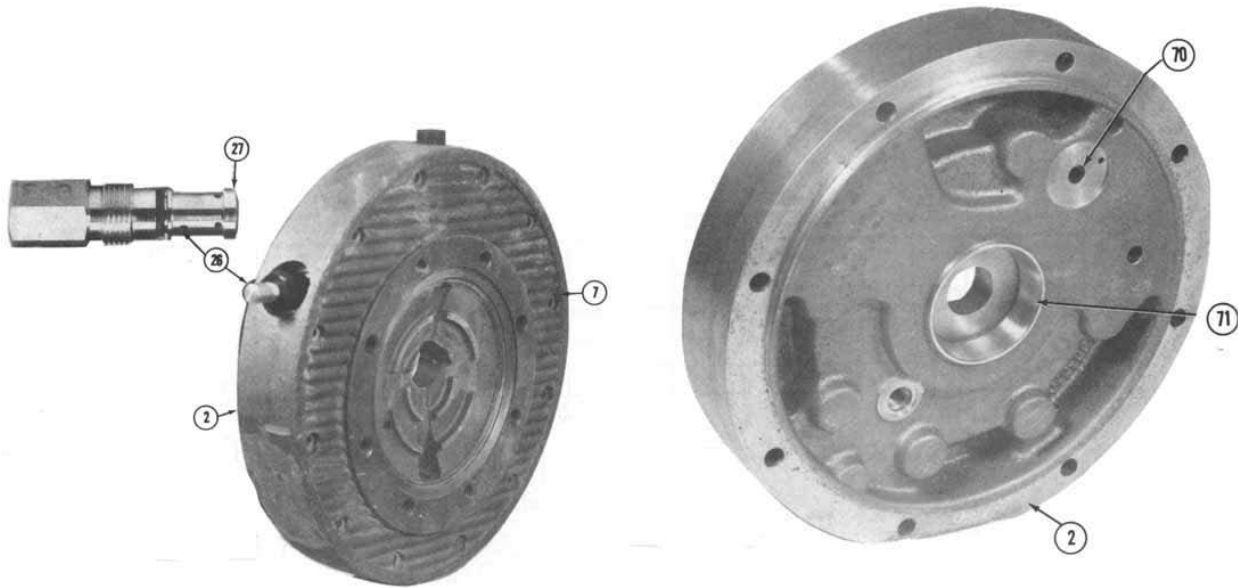

Figure 4 - Cover Plate and Relief Valve Assembly

Figure 5 - Cover Plate Assembly

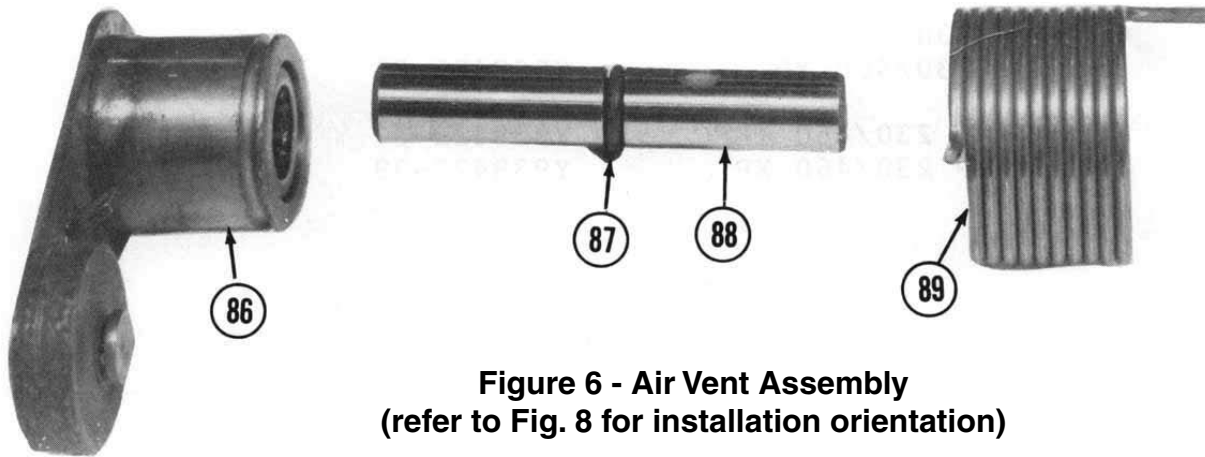

Figure 6 - Air Vent Assembly
(refer to Fig. 8 for installation orientation)

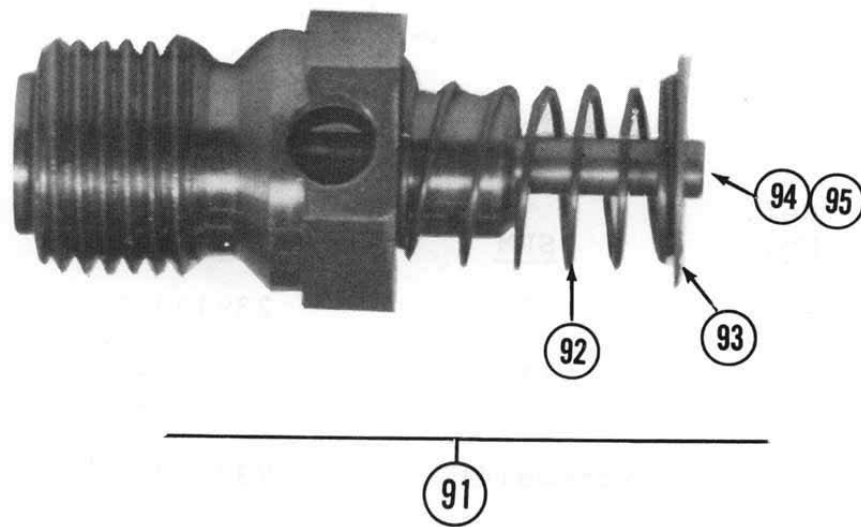

Figure 7 - Oil Replenishing Valve

Select Numbers Corresponding to Nameplate Model No.

Digits 4 & 5

572X-XX-XXXX

Basic Parts - Simplex
(See Fig. 1, 2, 3, 4, 5, 6, 7)

Digit 5 Plunger Diameter 1-3/16" - 1-5/8"

Ref. No.	Part Name	Part No.
1	Pump Housing	Y021831-01
2	Cover Plate	Y061075
5a	Data Plate	Y100103-02
5b	Drive Screws (4)	Y302299
7	Cap Screws (8) 3/8-16x2"	Y303280
8a	Gasket (2)	Y019458-01
8b	Gasket (2)	Y019458-02
8c	Gasket (2)	Y019458-03
8d	Obsolete Use	Y019458-03
8e	Gasket (2)	Y019458-0
13	Pipe Plug 1/4"	Y302287
16	Pipe Plug 1/2"	Y302288
18	Cap Screws (8) 3/8-16x7/8"	Y303279
19	Cap Gasket (2)	Y940647
22	Cup Bearing	Y303282
23	Oil Seal	Y303285
25	Shift Ring Assy. (includes 60 - 63)	Y945258
26a	Relief valve 50 - 200	Y945733-01
26b	" 100 - 900	Y945733-02
26c	" 800 - 4000	Y945733-03
R26d	O-Ring	Y302953
27	Relief Valve Washer	Y945381
33	Key	Y933912
38a	Seal Bushing	Y934073
38b	3/16" dia. Ball	Y302286
39	Retaining Ring	Y303711
40	Backup Ring	Y303709
41	O-Ring	Y303710

Ref. No.	Part Name	Part No.
53	Shift Ring Cap	Y100931
60a	Shift Ring	Y061399
60b	Reaction Ring	Y940648
61	Retaining Ring	Y100932
62	Rollers (101)	Y303276
63	O-Ring (1-3/8x1-1/8)	4130568216
64	Cap Screws (6) 10/32	Y300382
70	Expansion Plug	Y302281
86	Index Arm Assy.	Y100958
87	Air Vent O-Ring	Y302285
88	Shaft	Y933926
89	Spring	Y933923
91	Replenishing Valves (includes 91 thru 97)	Y943615
91a	Body	Y943503
92	Replenishing Valve	Y947383
93	Retaining Spring	Y933929
94	Stem	Y943504
95	Truarc Ring	4170105003
101	Cap Screw (6) 5/16-18	Y303823
102	1/8" Pipe Plug	Y305001
103	Key 3/16"x3/4"	Y304643
104	Coupling	Y304616
105	Hydraulic Oil	Y302950

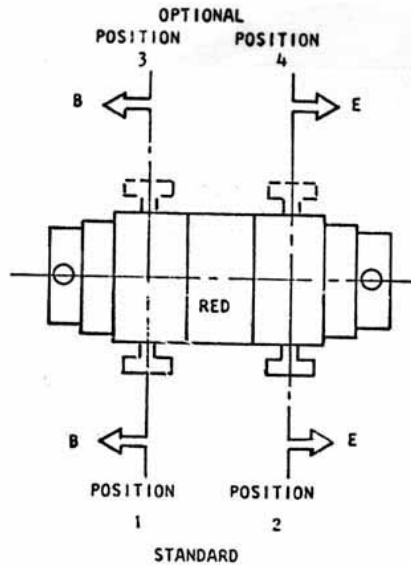

PUMP MODEL	STANDARD		OPTIONAL	
	POSITION 1	POSITION 2	POSITION 3	POSITION 4
5720 (C)	 Y 100958	 245299	 245299	 Y 100958

C PUMP

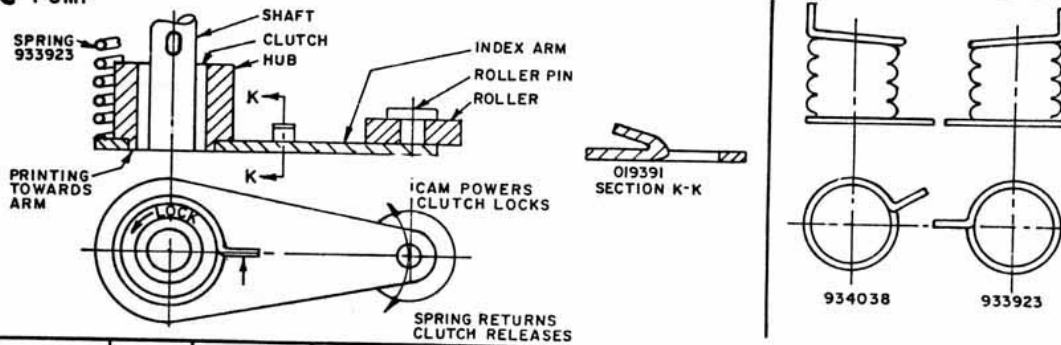

ASSEM. PT. NO.	POSITION				CLUTCH	PRINTED SIDE		INDEX ARM	HUB	ROLLER	ROLLER PIN	SPRING
	1	2	3	4		TOWARD ARM	AWAY FROM ARM					
C 100958	X		X		302280	X		019391	933922	940646	933925	933923
C 245299		X	X		302280		X	100610	933922	940646	933925	934038

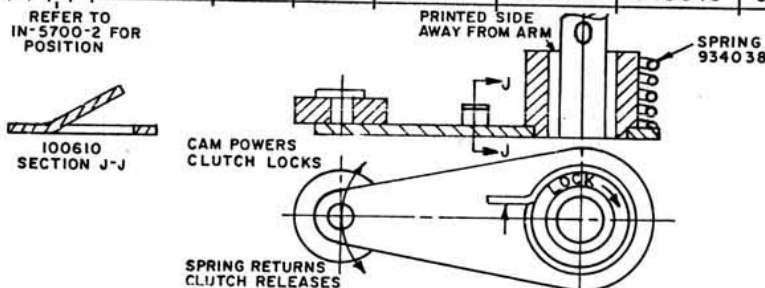

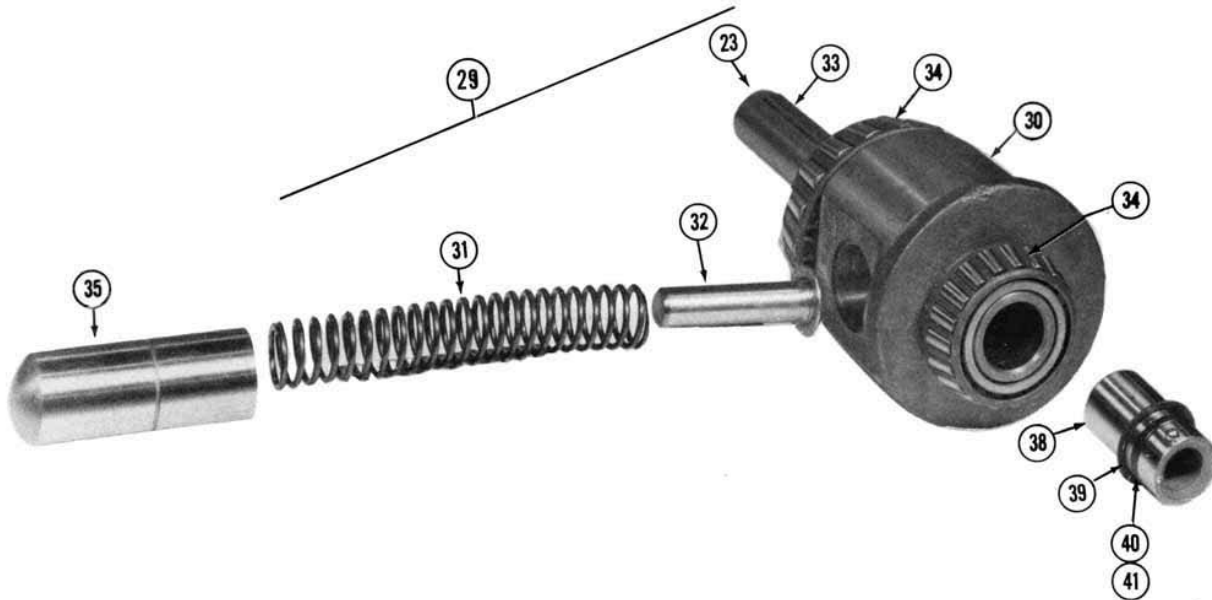

Figure 9 - Drive Shaft Plunger Assembly

Digit 5
572X-XX-XXXX

Drive Shaft - Plunger Assembly
(see Fig. 9)

Ref. No.	Part Name	1-3/16" Part No.	1-5/8" Part No.
29	Drive Shaft – Plunger Assembly (includes 30, 31, 32, 34a, 34b, & 35)	Y941117-01	Y941118-01
30	Drive Shaft	Y041853-02	Y041853-01
31	Spring	Y934077	Y934076
32	Guide Pin	Y940651-02	Y940651-01
33	Key	Y933912	Y933912
34a	Bearing Cone	Y302277	Y302277
34b	Bearing	Y303284	Y303284
35	Plunger	Y940649-02	Y940649-01

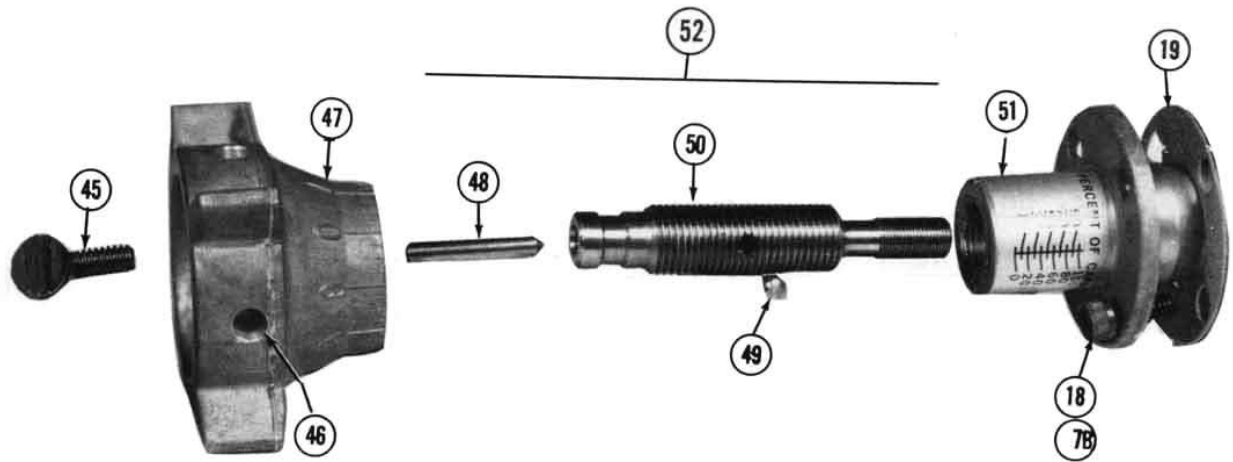

Figure 10 - Pneumatic Stroke Adjustment

Digit 10
572X-XX-XXXX

Capacity Adjustment

(see Fig. 10)

Ref. No. 52 - Micrometer - Y941121-01

Ref. No.	Part Name	1-3/16" Part No.
45	5/16-18 Screw	Y303290
46	1/4-20 Set Screw (2)	Y302290
47	Knob	Y041807
48	Lockpin	Y933918
49	Insert	Y40652
50	Adjustment Screw	Y940644-02
51A	Adjustment Screw Cap	Y100929
51B	Scale	Y952260

Check Valve Suction or Discharge Head Material
(see Fig. 11)

Ref. No.	Part Name	316 SS Part No.	C20 Part No.	Hastelloy Part No.	H ₂ SO ₄ Part No.
3	Complete Check	Y941632-91	Y941632-84	Y941632-82	Y941632-01
80	Body	Y941508-91	Y941508-84	Y941508-82	Y941508-84
81	Set	Y941510-91	Y941510-84	Y941510-82	Y941510-84
82	Ring	Y303541	Y303541	Y303541	Y303541
83	Guide	Y941509-82	Y941509-84	Y941509-82	Y941509-84
84	Retainer	Y941512-91	Y941512-82	Y941512-82	Y941512-82
85	Ball	Y941511-91	Y941511-82	Y941511-82	Y941511-84

Check Valves - Polypropylene
(not shown)

Ref. No.	Part Name	316 SS Part No.
3	Complete Check	Y948706 (Suction)
3	Complete Check	Y948707 (Discharge)
107	Insert	Y948704
108	Upper Body	Y948703
109	Lower Body	Y948702
110	Clamp	Y948705
111	O-Ring	Y305206
112	Ball	Y305207

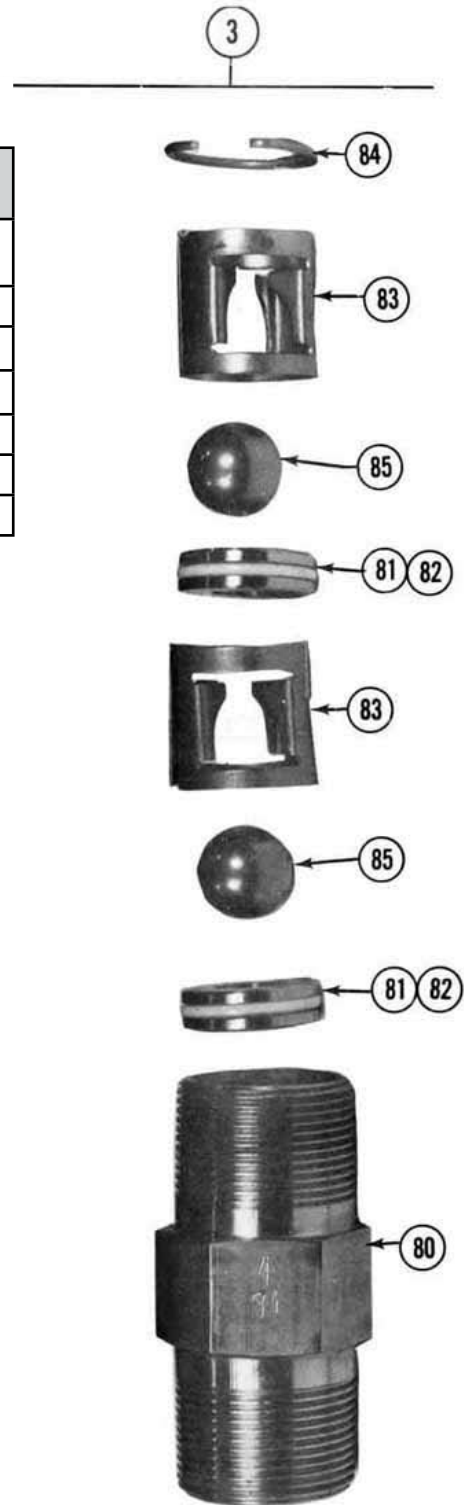

Figure 11 - Check Valve Assembly

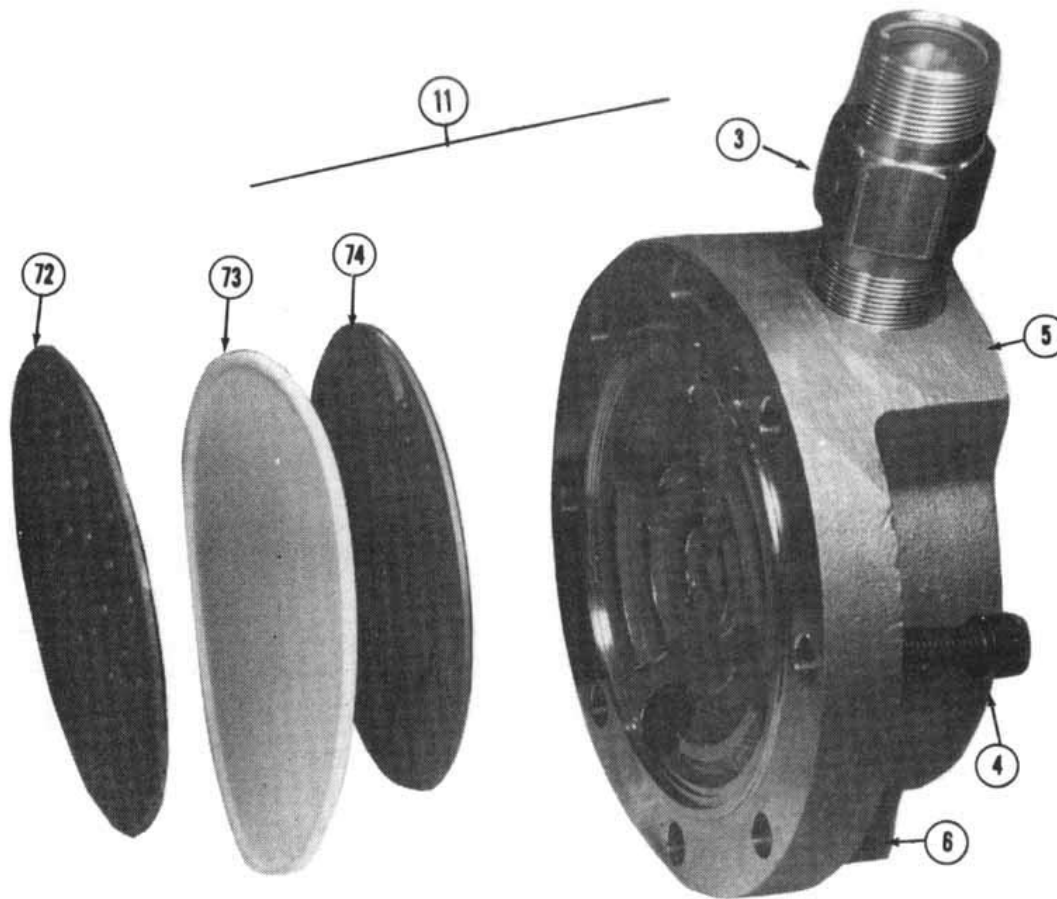
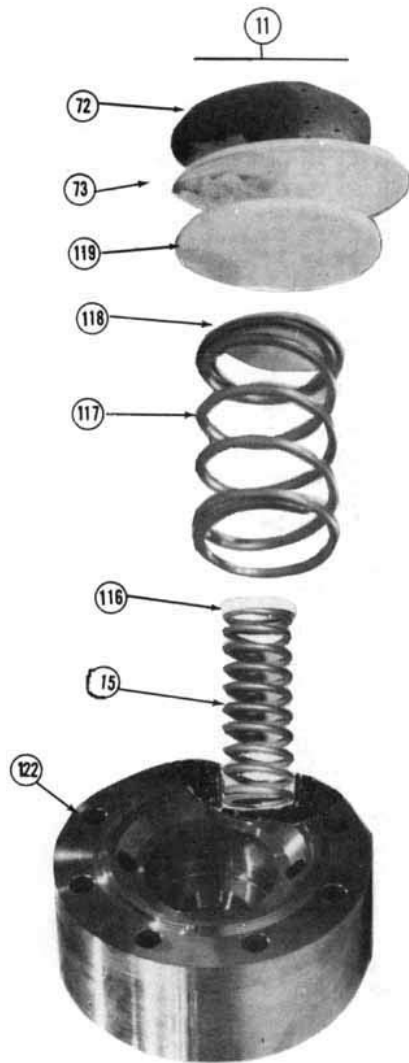

Figure 12 - Head Assembly

Digit 9
572X-XX-XXXX

Head Material
(see Fig. 12)

Ref. No.	Part Name	316SS Part No.	C20 Part No.	HC Part No.	H ₂ SO ₄ Part No.	Poly Part No.
11	Complete Assy.	Y954729-03	Y954729-04	Y954729-05	Y954729-06	Y954729-31
4	Cap Screw 5/8-11	Y303286	Y303286	Y303286	Y303286	--
4	Cap Screw 3/8-16	--	--	--	--	Y305219
5	Diaphragm Head	Y045262-91	Y045262-84	Y045262-82	Y045262-82	Y044040
6	Cap Screw 5/8-11	Y303287	Y303287	Y303287	Y303287	--
72	Diaphragm Plate (oil)	Y940643-79	Y940643-79	Y940643-79	Y940643-79	Y940643-79
73	Diaphragm	Y937000	Y937000	Y937000	Y937000	Y937000
74	Diaphragm Plate	Y940643-91	Y940643-94	Y940643-82	Y940643-82	--
	Washer 3/8"	--	--	--	--	Y305227
	Insert	--	--	--	--	Y948821



Ref. No. 195 - Double Diaphragm
(not shown)
Simplex Y957386

Ref. No.	Part Name	316 SS Part No.
180	Head	Y042742
181	Diaphragm	Y937000
182	Ball	Y303036
183	Spring	Y934001
184	Vent Screw	245292
185	5/16-24 Hex Nut	Y303040
186	5/8-11x4" Cap Screw	Y302983
187	1/8" Elbow	4161208001
188	1/8"x1-1/2" Nipple	Y303791
189	Wrought Iron Coupling	4161203001
190	Angle Valve	Y303793
192	5/8-11x5" Cap Screw	Y303554
193	1/8" Pipe Plug	Y305001

Figure 13 - Head Suction Lift Head Assembly

Digit 9
572X-XX-XXXX

Head - Hi Suction
(see Fig. 13)

Ref. No.	Part Name	316SS Part No.	C20 Part No.	HC Part No.	H ₂ SO ₄ Part No.
11	Complete Assembly	Y954729-23	Y954729-24	Y954729-25	Y954729-22
122	Diaphragm Head	Y043122-91	Y043122-84	Y043122-82	Y043122-79
116	Seat	Y942072-01	Y942072-01	Y942072-01	Y942072-01
116	Seat	Y942071-01	Y942071-01	Y942071-01	Y942071-01
118	Seat	Y942978-01	Y942978-01	Y942978-01	Y942978-01
117	Spring	Y942066-82	Y942066-82	Y942066-82	Y942066-82
117	Spring	Y942067-82	Y942067-82	Y942067-82	Y942067-82
117	Spring	Y94977-82	Y942977-82	Y942977-82	Y942977-82
119	Diaphragm Pad	Y942979-01	Y942979-01	Y942979-01	Y942979-01
123	Cap Screw 5/8"	Y300427	Y300427	Y300427	Y300427

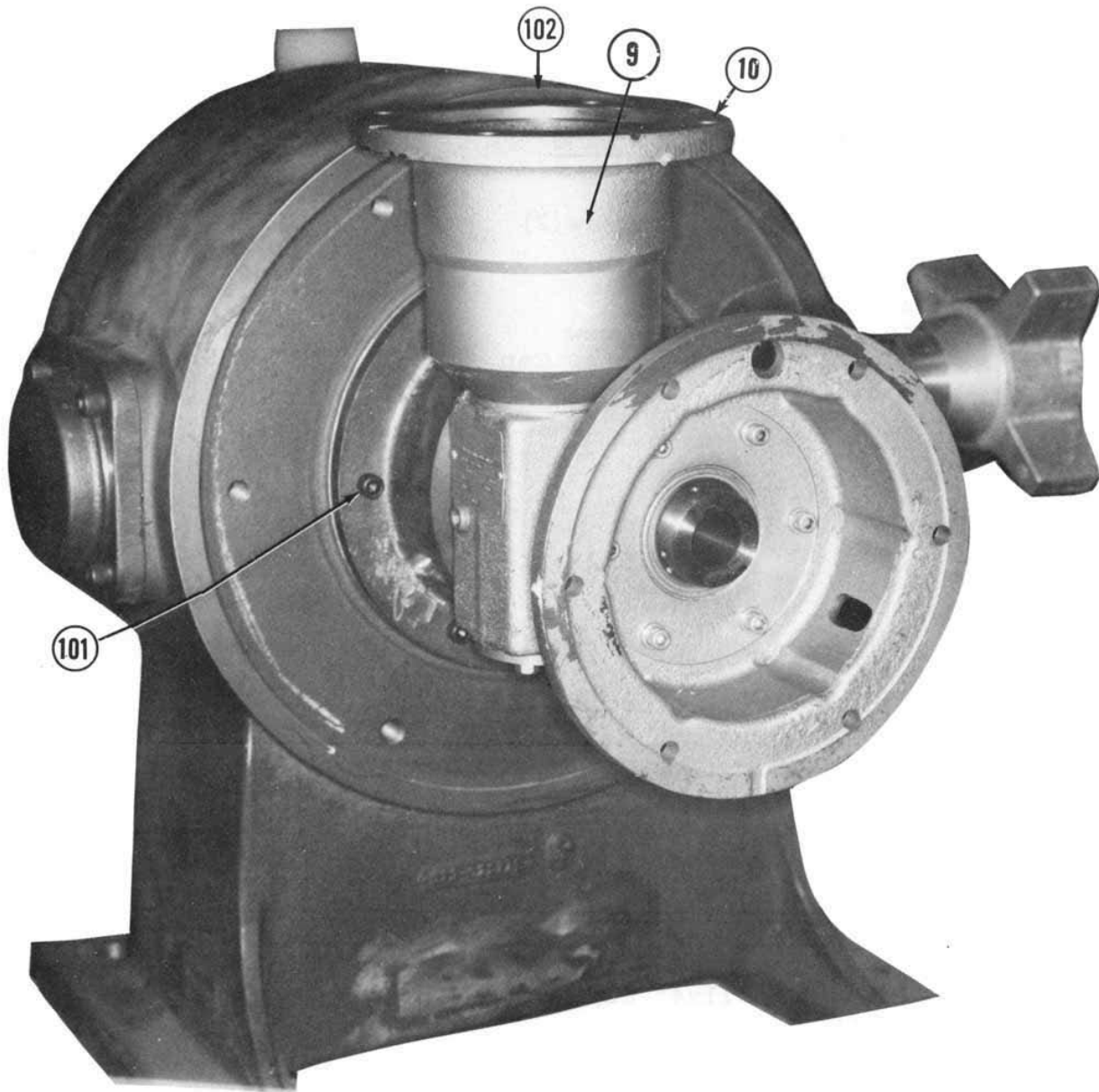

Figure 14 - Speed Reducer

Digit 7
572X-XX-XXXX

Digit 8
572X-XX-XXXX

Reducer Size	Simplex	
Ref. No.	Part Name	316SS Part No.
9	58	239499-1
9	88	239499-2
9	117	239499-3
9	175	239499-4
10	Cap Screws (4)	Y303823

Digit 6
572X-XX-XXXX

Motors
(not shown)
Ref. No. 15 - 56C Frame

Ref. No.	Part Name	316SS Part No.
1/2 Hp	115/230 TEFC	Y938423-09
	115/230 XP	Y938423-11
	230/460 TEFC	Y938423-25
	230/460 XP	Y938423-27
3/4 Hp	115/230 TEFC	Y938423-13
	115/230 XP	Y938423-15
	230/460 TEFC	Y938423-29
	230/460 XP	Y938423-31
1 Hp	230/460 TEFC	Y938423-33
	230/460 XP	Y938423-35
1-1/2 Hp	230/460 TEFC	Y938423-37
	230/460 XP	Y938423-39

Recommended Spare Parts Sets, Model 5720 Pump

These are the recommended parts for one year's operation of a simplex pump. For multiple pump orders, one set for each plunger diameter and liquid end material for each 2 or 3 pumps will be satisfactory.

Each set includes:

- | | |
|------------------------|-----------------------|
| 1 – Oil Seal | 4 – Valve guides |
| 1 – Set of 4 "O" Rings | 2 – Valve retainers |
| 1 – Plunger spring | 4 – Valve ball checks |
| 1 – Diaphragm | 4 – Valve "O" rings |
| 4 – Valve seats | 1 – Back up ring |

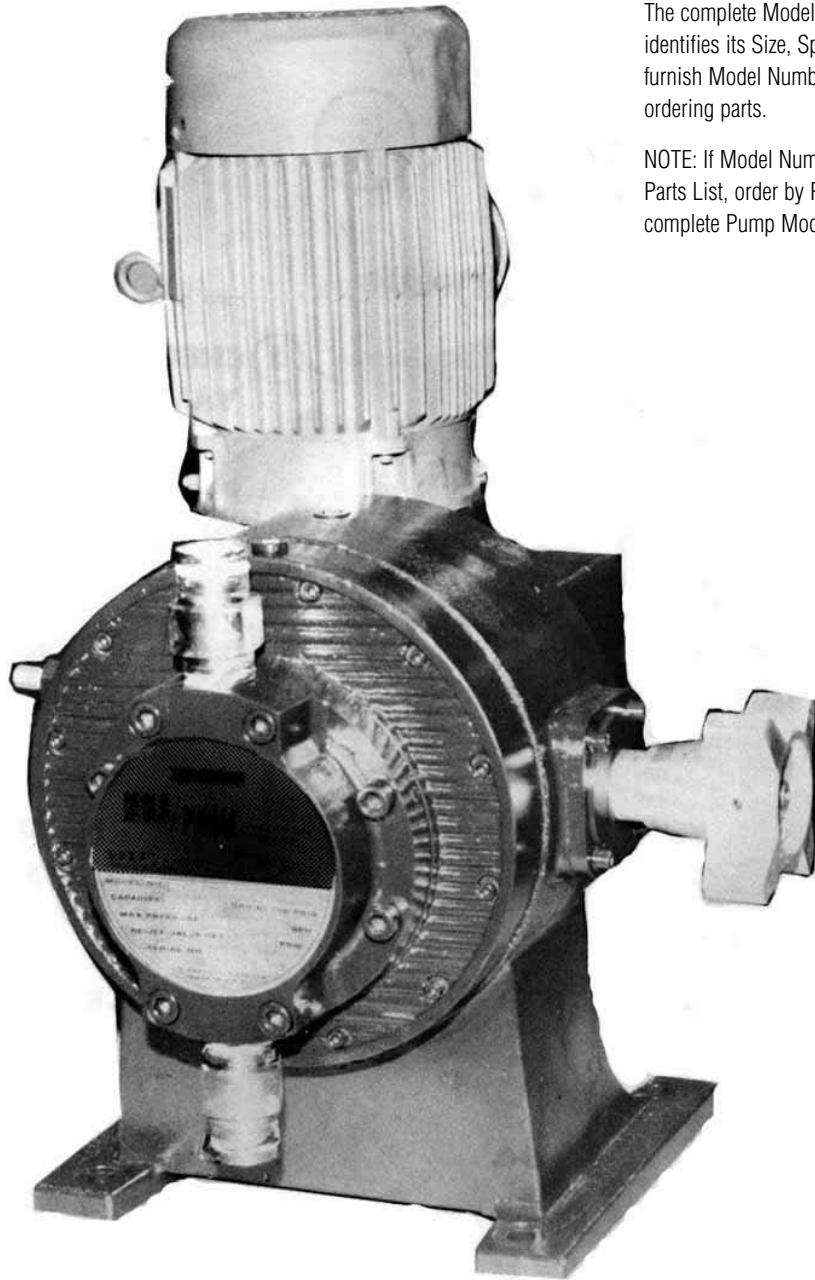

The complete Model Number and Serial No. of this Pump identifies its Size, Speed and Materials of Construction. Always furnish Model Number appearing on Pump Nameplate when ordering parts.

NOTE: If Model Number designation does not appear on this Parts List, order by Part Name and Reference Number, plus complete Pump Model Number and Serial No.

5	7	3							
----------	----------	----------	--	--	--	--	--	--	--

PRODUCT
CODE

LIQUID
ENDS

PLUNGER
DIAMETER

MOTOR

GEAR
REDUCER

SPM

LIQ. END
MATERIALS

CAPACITY
ADJUSTMENT

1. Simplex
2. Duplex

1. 2-1/4"

3. 1 Hp
4. 1-1/2 Hp
5. 2 Hp

1. 58
2. 88
3. 117
4. 175

3. 31 SS
4. Carp. #20
6. H₂SO₄
7. Polypro.
8. Special

1. Manual
2. Pneu. w/o
Signal Trim
7. Pneu w/
Signal Trim
9. Special

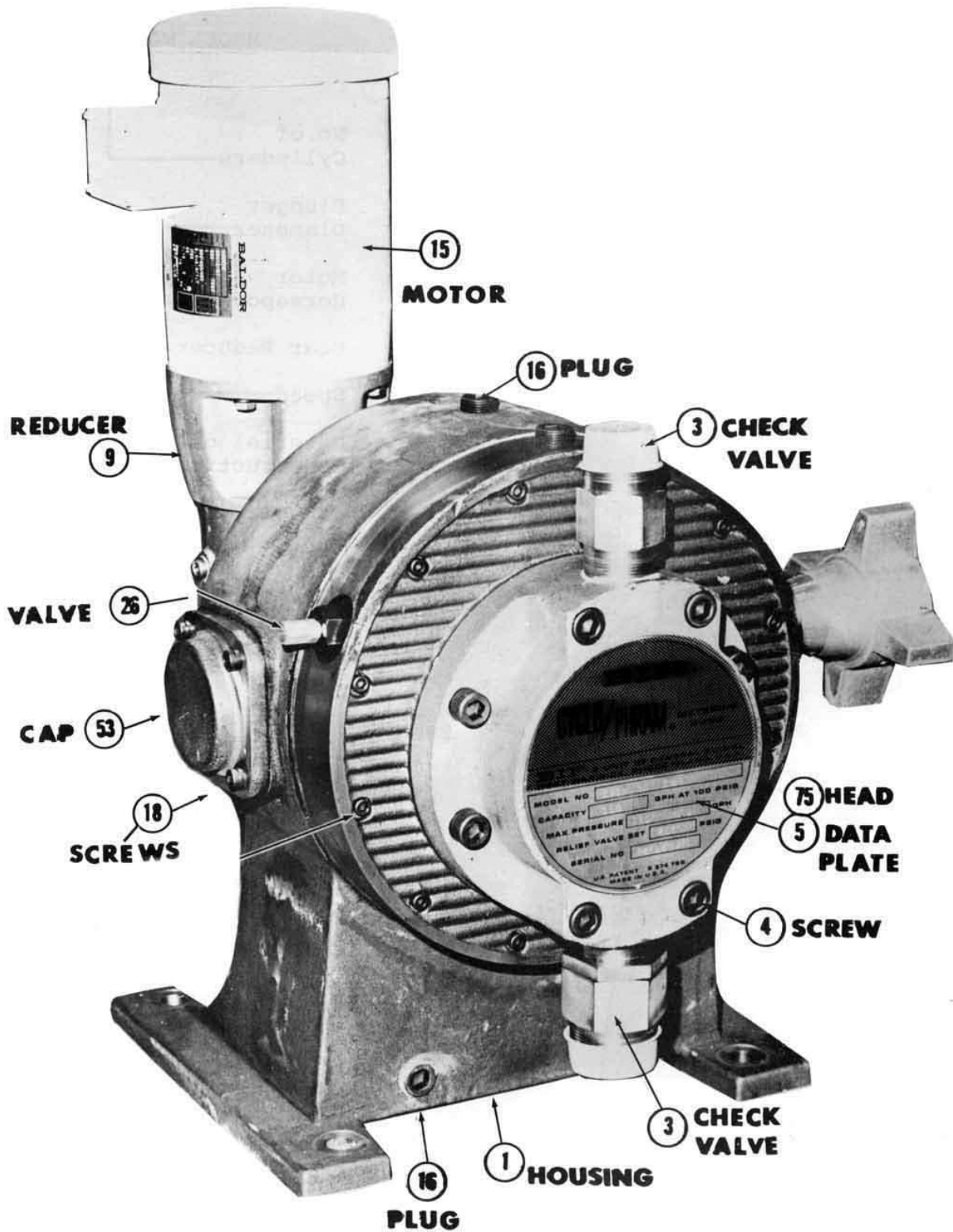

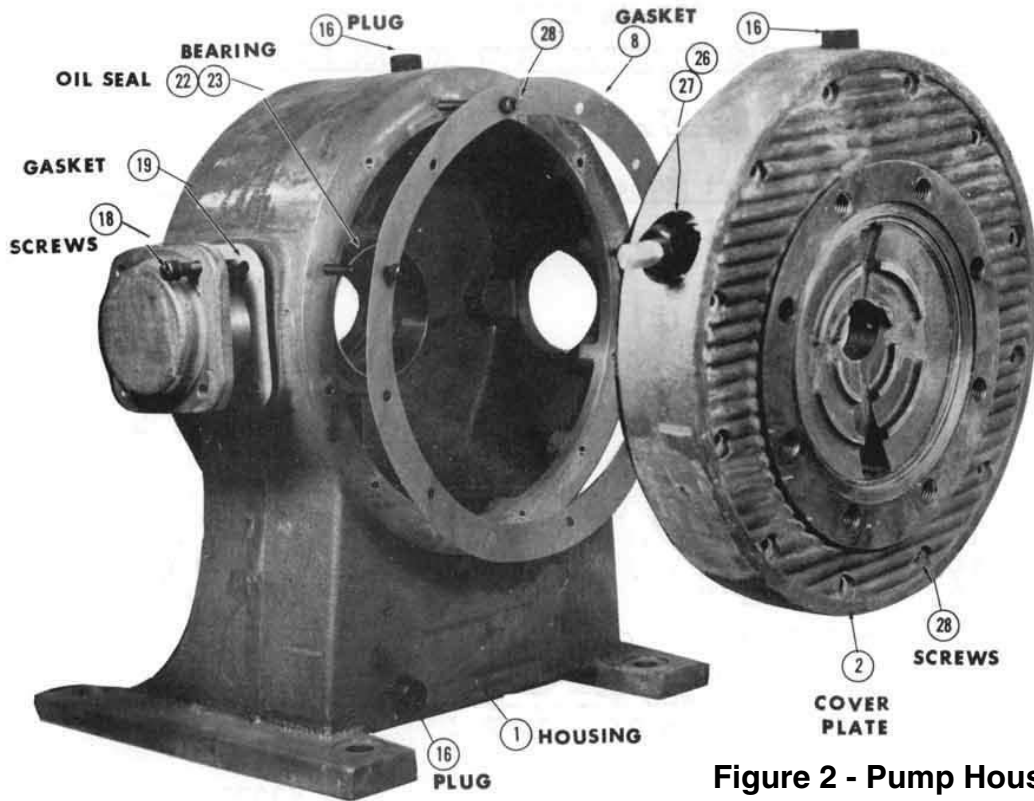

Figure 2 - Pump Housing and
Figure 2 - Pump Housing and
Cover Plate Assembly

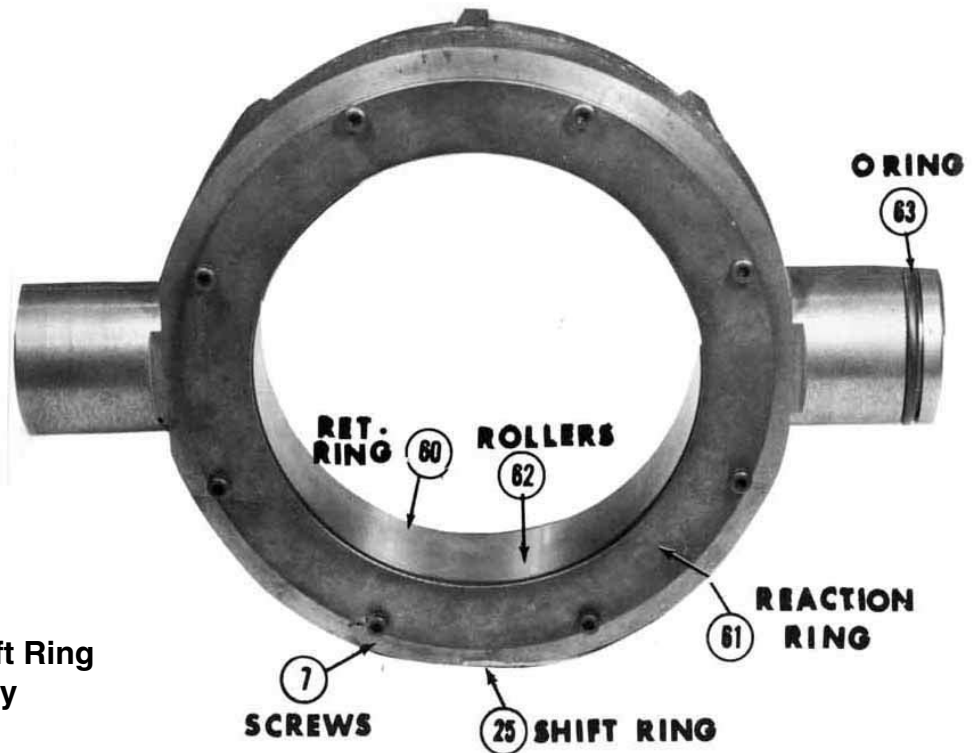

Figure 3 - Shift Ring
Assembly

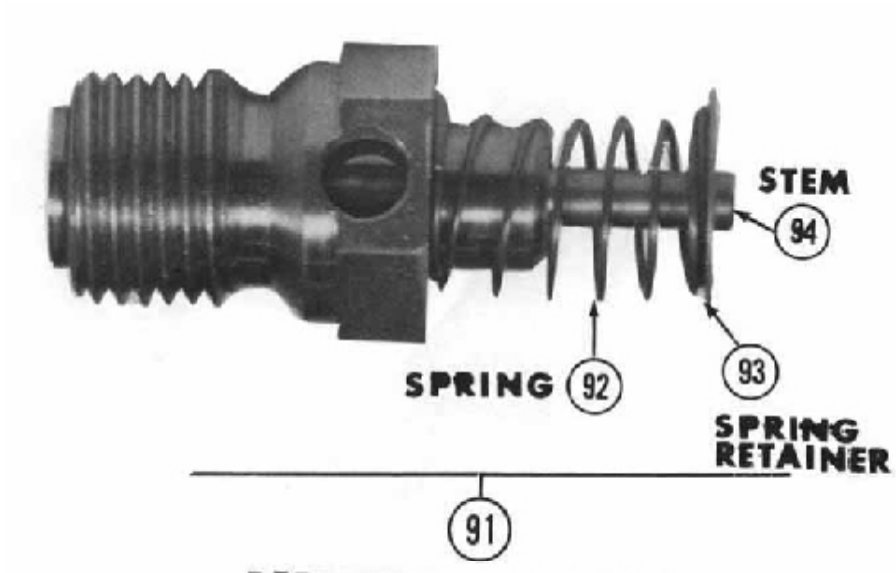

Figure 4 - Replenishing Valve Assembly

Select Numberst Correspondong to Nameplate Model No.

Digit 4
573X-XX-XXXX

Basic Parts - Simplex
(see Fig. 1, 2, 3, 4) Y941452-02

Ref. No.	Part Name	Part No.
1	Pump Housing	Y021774
2	Cover Plate	Y022009
5	Data Plate	Y100103-01
7	Cap Screws (8)	Y303484
8a	Gasket (2)	Y100102-01
8b	Gasket (2)	Y100102-02
8c	Gasket (2)	Y100102-03
8d	Gasket (2)	Y100102-04
8e	Gasket (1)	Y100102-05
15	Motor	See page 13
16	Pipe Plug (3) 3/4"	Y302969
18	Cap Screws (18) 3/8-16	417-0053-074
19	Cap Gasket (2)	Y936974
22	Cup Bearing	Y302973
23	Oil Seal	Y305058
25	Shift Ring Assy. (includes #60-#63)	Y100875
26	Relief Valve 25-1000psi	Y305091
28	Cap Screws (12) 5/16-18	Y302976
53	Shift Ring Cap	Y100106
60a	Shift Ring	Y061400
60b	Reaction Ring	Y102262
61	Retaining Ring	Y100105
62	Rollers (105)	Y302967
63	O-Ring	Y302968
64	Cap Screws (6) 7/16-14	Y303974
91	Replenishing Valve (includes #91-#96)	Y948027
91a	Body	Y947977
92	Spring	Y948028
93	Retainer Spring	Y947978
94	Stem	Y947979
102	Pipe Plug 1/8"	Y305001
103	Drive Screws (4)	Y302299
104	Coupling (Motor)	Y304616 Part Not Shown
105	Hydraulic Oil	Y302950 Part Not Shown

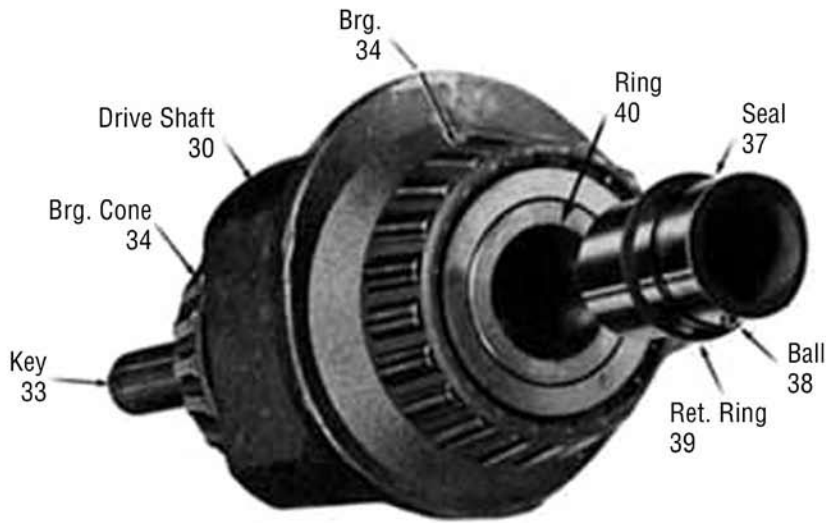

**Figure 5 - Drive Shaft
Plunger Assembly**

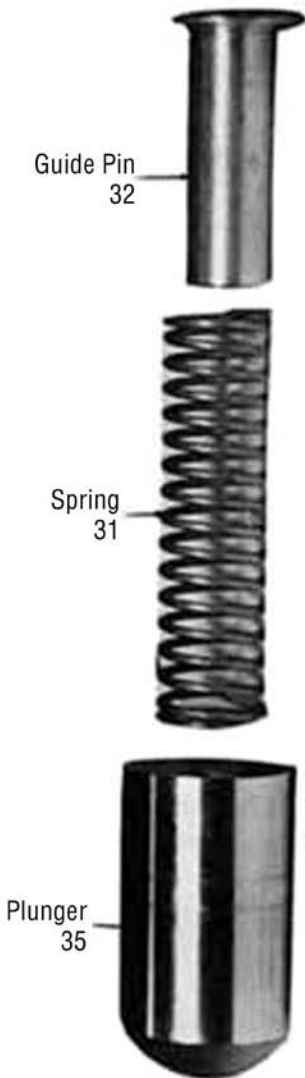

Digit 5
573X-XX-XXXX

Drive Shaft - Plunger Assembly

Ref. No.	Part Name	Part No.
29	Drive Shaft – Plunger Assy.	Y941455-01
30	Drive Shaft	Y042230-02
31	Spring	Y936982
32	Guide Pin	Y936983-02
33	Key	Y933912
34	Bearing	Y302972
35	Plunger	Y936981
36	Key 3/16 x 3/4 (motot)	Y304643
37	Seal Bushing	Y936984
39	Retaining Ring	Y302977
40	O-Ring	Y303223

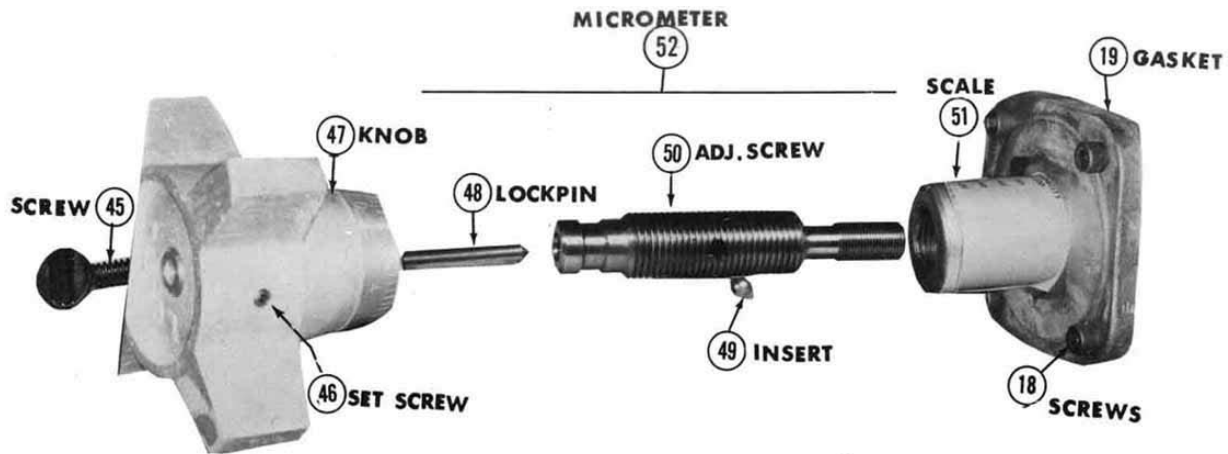

Figure 6 - Capacity Adjustment

Digit 10
573X-XX-XXXX

Capacity Adjustment
(Fig. 6)

Ref. No.	Part Name	Part No.
52	Micrometer Assy. Complete	Y941459
45	Set Screw 3/8-24x3/8	Y303486
46	Set Screw 5/16-18x1 (2)	Y302970
47	Adjustment Knob	Y042228
48	Lock Pin	Y936972
49	Insert	Y936973
50	Adjustment Screw	Y100108
51a	Adjustment Cap	Y100109
51b	Stroke Scale	Y952261

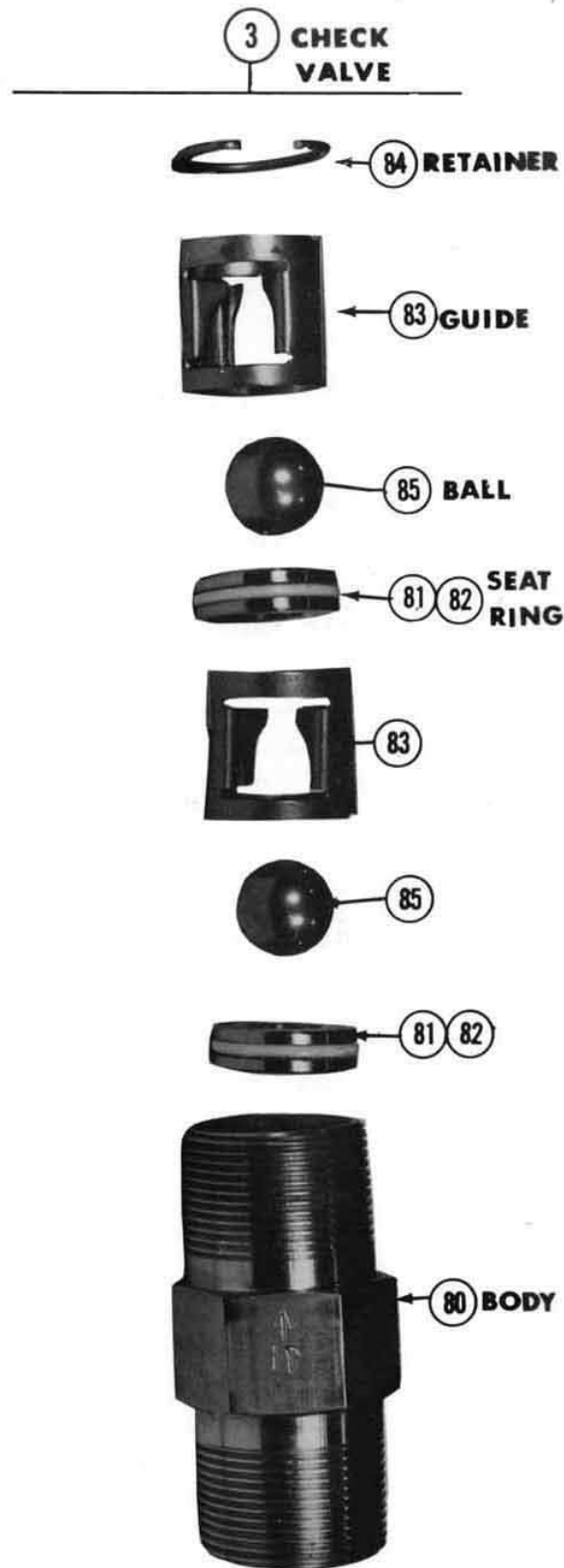

Figure 7 - Capacity Adjustment

Digit 11
573X-XX-XXXX-XX

Check Valves (See Fig. 7)

Suction 2"					
Ref No.	Part Name	316SS Part No.	C20 Part No.	Hast C Part No.	H ₂ SO ₄ Part No.
3	Complete Check	Y934052-91	Y934052-84	Y934052-82	Y934052-01
80a	Body	Y941202-91	Y941202-84	Y941202-82	Y941202-84
80b	Body	Y941203-91	Y941203-84	Y941203-82	Y941203-84
83	Guide (2)	Y941201-91	Y941201-84	Y941201-82	Y941201-84
82	O-Ring	Y303365	Y303365	Y303365	Y303365
85	Ball	Y941204-91	Y941204-82	Y941204-82	Y941204-81

Polypropylene - Suction (not shown)			
Ref No.	Part Name	Part No.	Note: Suction seat is part of body.
3	Complete Check	Y948728	
107	Insert	Y948710	
108	Upper Body	Y948709	
109	Lower Body	Y948708	
110	Clamp	Y948711	
111	O-Ring (2)	Y305265	
112	Ball	Y304361	

Digit 12
573X-XX-XXXX-XX

Check Valves (See Fig. 7)

Suction 1-1/2"					
Ref No.	Part Name	316SS Part No.	C20 Part No.	Hast C Part No.	H ₂ SO ₄ Part No.
3	Complete Check	Y936987-91	Y936987-84	Y936987-82	Y936987-01
80	Body	Y939024-91	Y939024-84	Y939024-82	Y939024-91
81	Seat (2)	Y936989-91	Y936989-84	Y936989-82	Y936989-84
82	O-Ring	Y303493	Y303493	Y303493	Y303493
83	Guide (4)	Y936990-82	Y936990-84	Y936990-82	Y936990-84
84	Retainer	Y936991-91	Y936991-82	Y936991-82	Y936991-82
85	Ball (2)	Y936992-91	Y936992-82	Y936992-82	Y936992-81

Polypropylene - Suction (not shown)			
Ref No.	Part Name	Part No.	
3	Complete Check	Y948727	
107	Insert	Y948710	
108	Upper Body	Y948709	
109	Lower Body	Y948708	
110	Clamp	Y948711	
111	O-Ring (2)	Y305265	
112	Ball	Y304361	

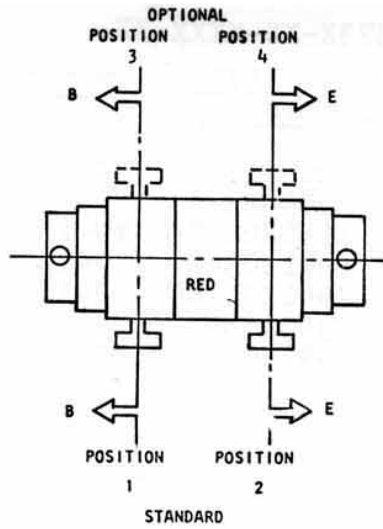

PUMP MODEL	STANDARD		OPTIONAL	
	POSITION 1	POSITION 2	POSITION 3	POSITION 4
5730 D				

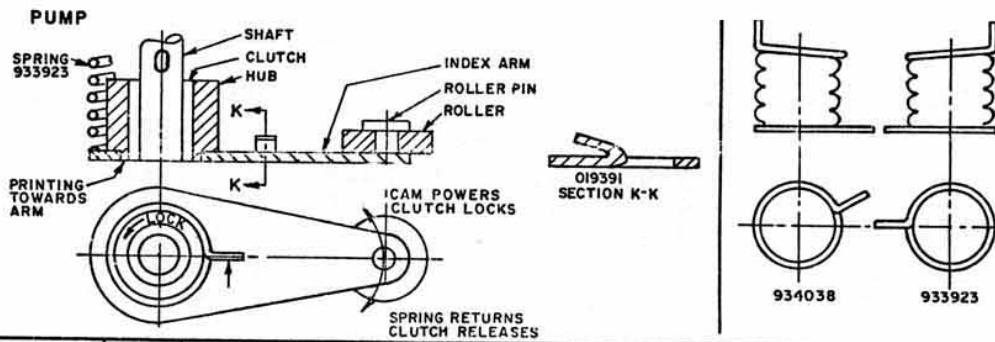

	ASSEM. PT. NO.	POSITION				CLUTCH	PRINTED SIDE		INDEX ARM	HUB	ROLLER	ROLLER PIN	SPRING
		1	2	3	4		TOWARD ARM	AWAY FROM ARM					
D	100112	X			X	302971	X		019391	936975	940646	933925	933923
D	246300	X	X			302971		X	100610	936975	940646	933925	934038

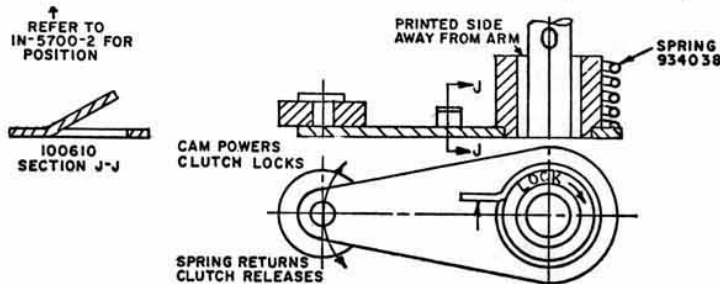

Figure 8 - Air Vent Installation Orientation

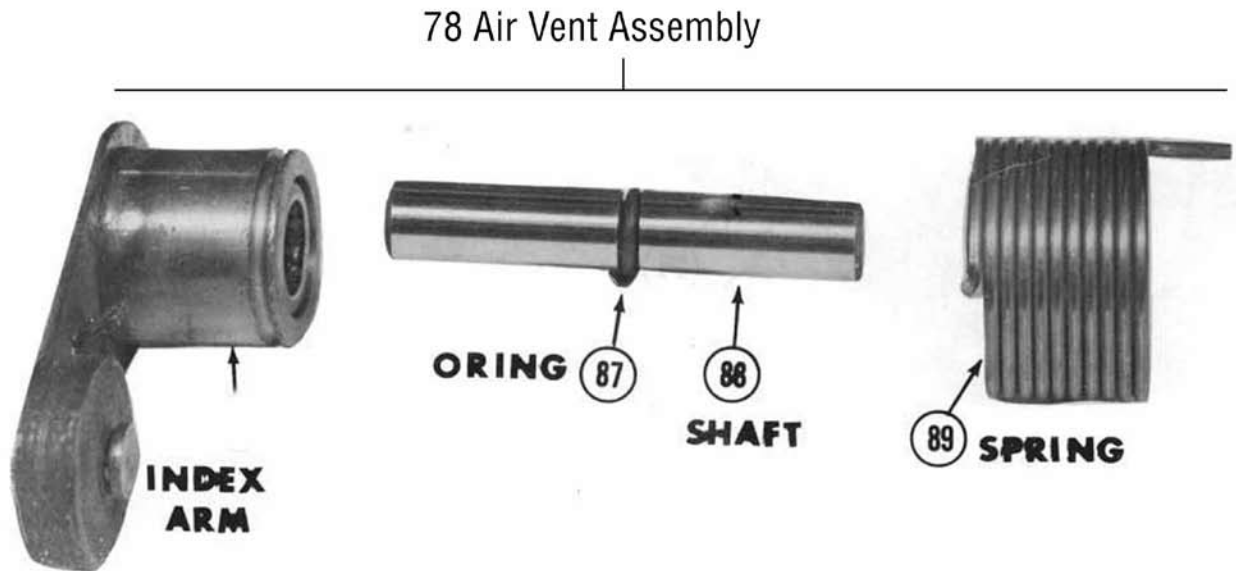

Figure 9 - Index Arm Assembly

Digit 4

573X-XX-XXXX

Air Vent
(See Fig. 9)
See Fig. 8 for Air Vent Installation Orientation

Ref. No.	Part Name	Part No.
78a	Air Vent Assy. Complete (R.H.)	Y941460-01
79a	Index Arm Assy. (R.H.)	Y100112
87	O-Ring	Y302300
88	Air Escape Shaft	Y936976
89a	Spring	Y933923
78b	Air Vent Assy. Complete (L.H.)	Y941460-02
79b	Index Arm Assy. (L.H.)	Y245300
87	O-Ring	Y302300
88	Air Escape Shaft	Y936976
89b	Spring	Y934038

Select Numbers Corresponding to Nameplate Model No.

Digit 9
572X-XX-XXXX

Head Material
(see Fig. 12)

Ref. No.	Part Name	316SS Part No.	C20 Part No.	HC Part No.	H ₂ SO ₄ Part No.	Poly. Part No.
11	Complete Assy.	Y941458-21	Y941458-24	Y941458-25	Y941458-26	Y941458-31
4	Cap Screw 5/8-11	Y302983	Y302983	Y302983	Y302983	--
6	Cap Screw 5/8-11	410053115	4170053115	4170053115	4170053115	Y303554
72	Diaphragm Plate	Y102484-79	Y102484-79	Y102484-79	Y102484-79	Y102484-79
73	Diaphragm	Y936985	Y936985	Y936985	Y936985	Y936985
74	Diaphragm Plate	Y120484-91	Y102484-84	Y102484-82	Y102484-84	--
75	Head D	Y021779-91	Y021779-84	Y021779-82	Y021779-91	Y044051-66
76	Diaphragm Insert					Y044157-66
77	Plate					Y949535

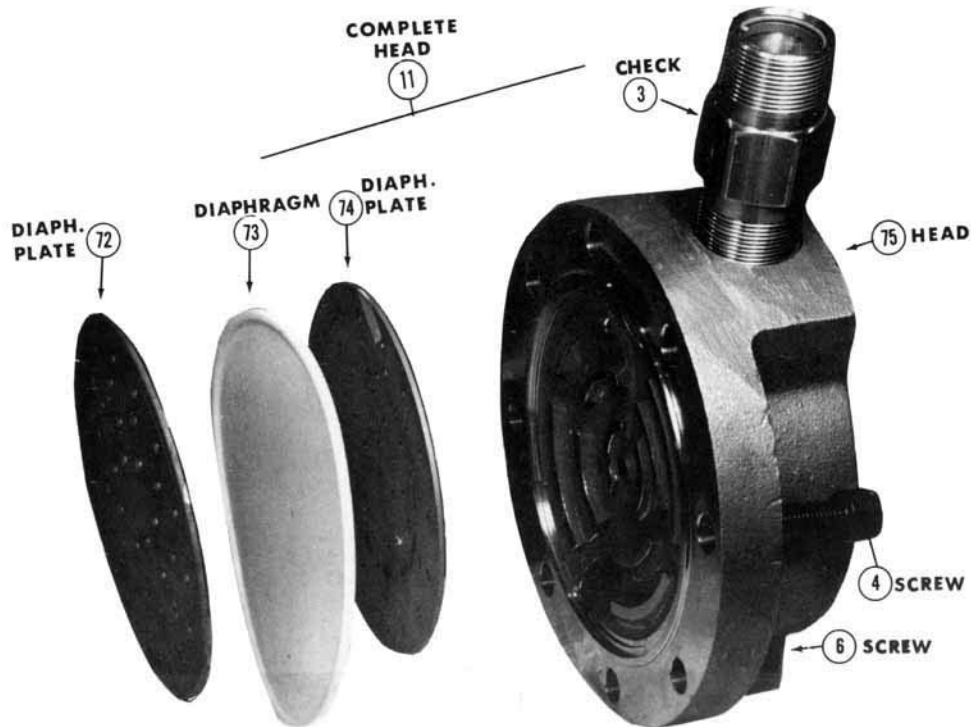

Figure 10 - Head Assembly

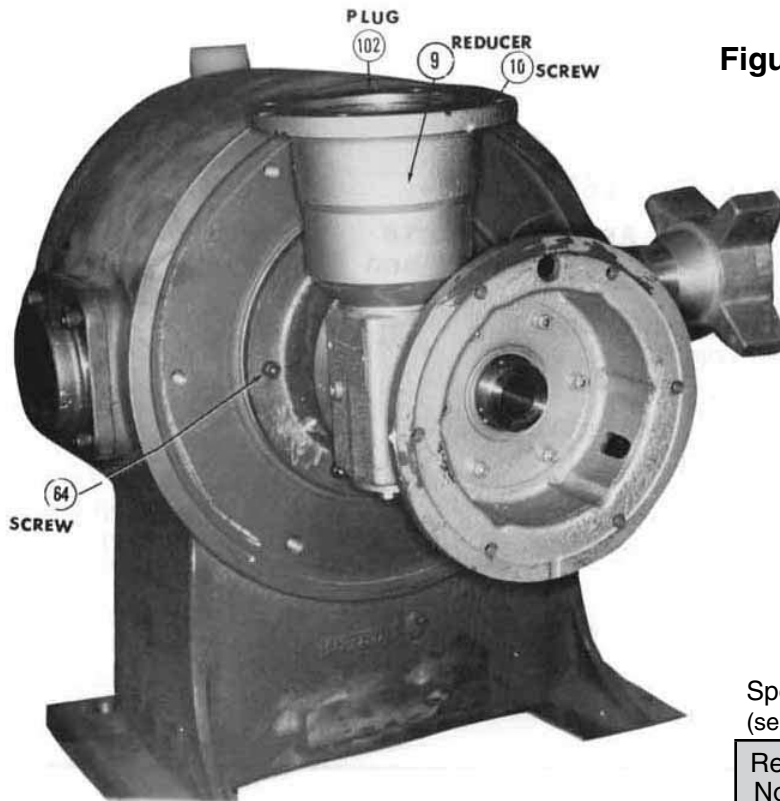

Figure 11 - Speed Reducer

Digit 8
572X-XX-XXXX

Speed Reducer
(see Fig. 11)

Ref. No.	SPM	Part No.
9a	58	239499-1
9b	88	239499-2
9c	117	239499-3
9d	175	239499-4
10	Cap Screws (4)	Y303823

Digit 6
572X-XX-XXXX

Motors
(see Fig. 1)

Ref. No.	Hp	Part Name	Part No.	Field
15		56 C Frame		
15a	3/4 Hp	115/230 TEFC	Y938423-13	1
15b		115/230 XP	Y938423-15	2
15c		230/460 TEFC	Y938423-29	3
15d		230/460 XP	Y938423-31	4
15e	1	230/460 TEFC	Y938423-33	5
15f		230/460 XP	Y938423-35	6
15g	1-1/2 Hp	230/460 TEFC	Y938423-39	7
15h		230/460 XP	Y938423-39	8

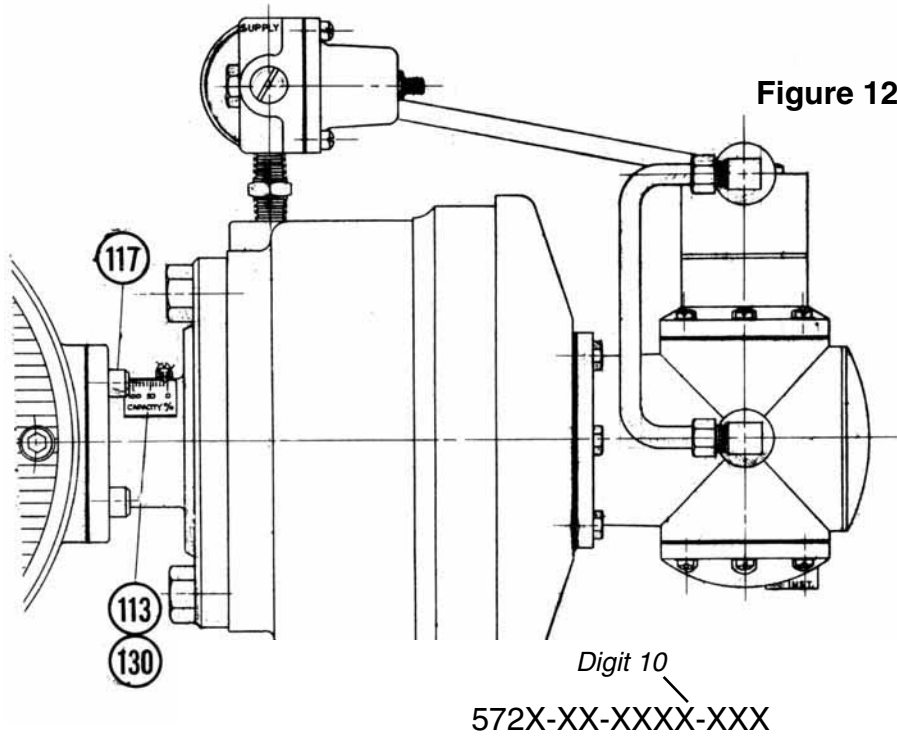
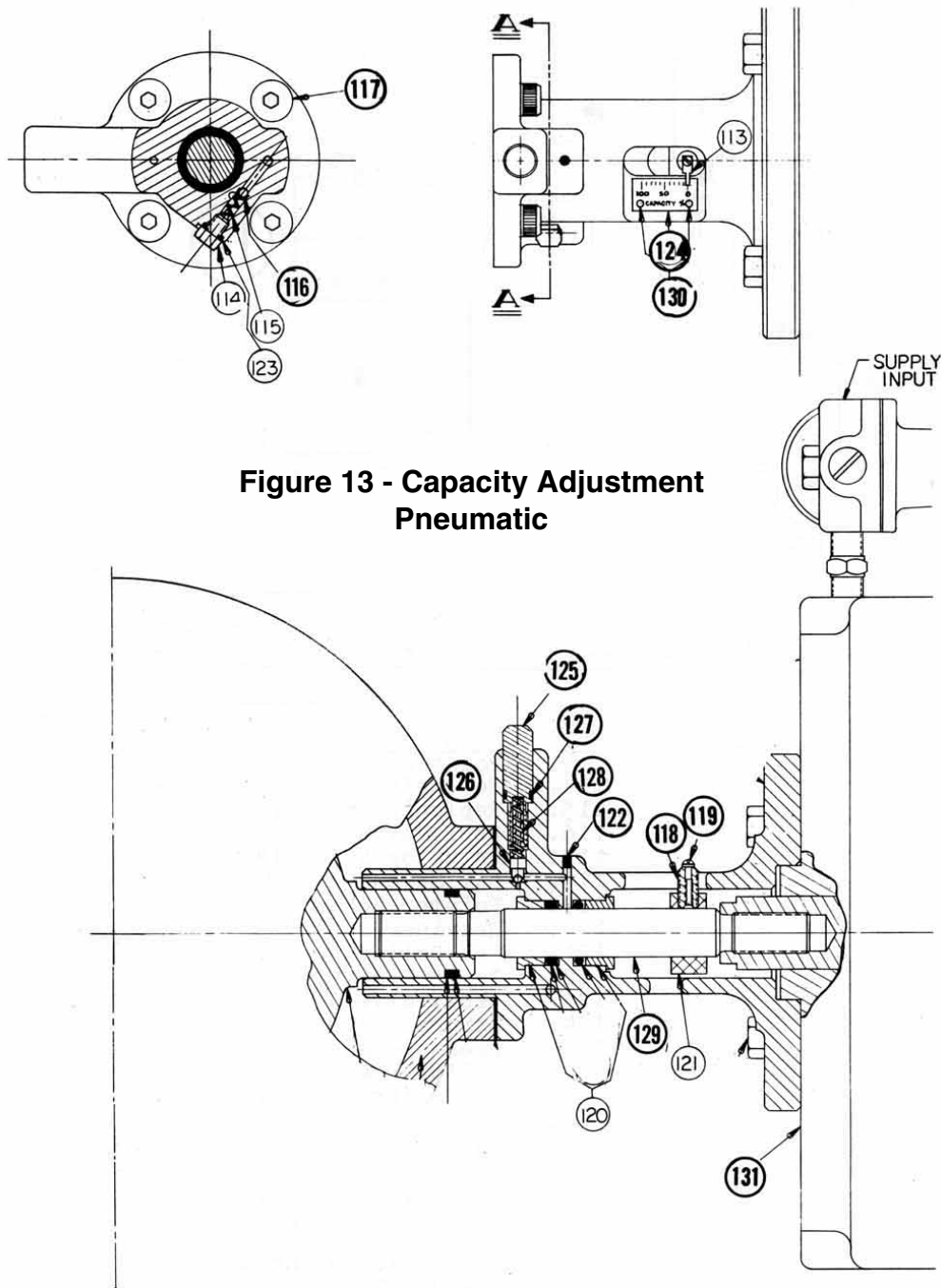

Figure 12 - Capacity Adjustment Pneumatic

Capacity Adjustment Pneumatic
(see Fig. 12 & 13)

Ref. No.	SPM	Part No.
113	Pointer	071-Y940510
114	Replenishing Valve Screw	071-Y940669
115	Replenishing Spring	071-Y040670
116	Replenishing Valve Ball	Y302286
117	Actuator Screw (4)	417-0052-153
118	Set Screw	Y942205
119	Pointer Screw	Y30250
120	Retainer Seal	Y945180
121	Set Collar	Y303918
122	Taper Pin	Y303919
123	Replenishing Valve O-Ring	Y302285
124	Stroke Scale	Y942204
125	Pressure Adjustment Screw	Y946289
126	Follower Assembly	Y946291
127	O-Ring (Pres. Adj. Screw)	Y304629
128	Relief Valve Spring	Y304653
129	Connecting Rod	Y942203
130	Drive Screw (2)	Y300354
131	Pneumatic Cylinder Actuator (3-15psi)	Y942866-01
132	Pneumatic Cylinder Actuator (3-27psi)	Y942866-02



**Figure 13 - Capacity Adjustment
Pneumatic**

NOTE: All parts listed and shown are for Simplex Pump only. For parts for Duplex Pump, when ordering parts furnish Pump Model Number and Serial No.

Series 5730 - Recommended Spare Parts Sets, Model 5730 Pump

These are the recommended spare parts for one year's operation of a simplex pump. For multiple pump orders, one set per pump is recommended. Each set includes:

- | | | | |
|--------------------|-----------------------|------------------------|---------------------|
| 1 – Oil Seal | 6 – Valve guides | 1 – Set of 4 “O” Rings | 1 – Retainer |
| 1 – Plunger Spring | 3 – Valve ball checks | 1 – Diaphragm | 3 – Valve “O” Rings |
| 2 – Valve Seats | 1 – Retaining Ring | | |



Accessories



Chemical Feed Systems

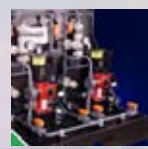

Measuring and Control Technology



Transfer Pumps

Metering Pumps