

INSTALLATION & MAINTENANCE MANUAL

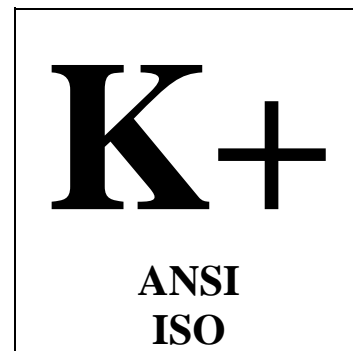

HORIZONTAL END-SUCTION PUMPS

ANSI MODELS: K+1516, K+326, K+326s, K+3156, K+436, K+1518 and
K+3158

ISO MODELS: K+i32160, K+i50160, K+i65160, K+i32200 and
K+i40200

JIS MODELS: K+j40160, K+j40200, K+j50200, K+j50160, and
K+j65160

Issued January, 2007

T.S.U.

◆◆◆◆*Do not run dry*◆◆◆◆

**This pump is NOT self-priming. The pump
must be filled with liquid before starting
otherwise severe damage may occur.**

ANSIMAG[®]
"Simple by Design"



TABLE OF CONTENTS

1-	LIMITED WARRANTY	4
2-	PUMP IDENTIFICATION CODES	7
3-	SAFETY CHECK LIST	9
4-	PRINCIPLES OF MAGNETIC DRIVE PUMPS	10
5-	PUMP INSTALLATION	11
	5-a Piping	
	5-b Foundation	
	5-c Installation and Electrical Connections	
	5-d Earthing Arrangement	
6-	PUMP START UP AND SHUTDOWN	14
	6-a Pre-Start Check List	
	6-b Start Up and Operation	
	6-c Shutdown Procedure	
7-	DISASSEMBLY AND MAINTENANCE	17
	7-a Basic Disassembly for Inspection	
	7-b Inspection Checklist	
	7-c Detailed Wear Parts Tolerances	
	7-d Parts Replacement Procedures	
8-	WET END ASSEMBLY (ANSI and ISO Pumps)	24
	8-a Shaft/Containment Shell assembly	
	8-b Impeller Assembly	
	8-c Wet End Assembly	
9-	DRIVE END ASSEMBLY	27
	ANSI Pumps with NEMA Motors:	
	9-a Mounting Outer Drive	
	9-b Mounting Bracket to Motor	
	9-c Mounting Motor Risers / Foot	
	9-d Mounting Drive End to Wet End	
10-	DRIVE END ASSEMBLY	30
	ANSI or ISO Pumps with IEC Motors:	
	10-a Mounting Adapter, Outer Drive and Foot	
	10-b Mounting Drive End to Wet End	

1. Limited Warranty

Two year limited warranty

Ansimag pumps and parts are warranted by Ansimag to the original user against defects in workmanship and materials under normal use for two years after the date of purchase. Any part returned to an Ansimag- designated, authorized service location, shipping cost prepaid, will be evaluated for defects. Parts determined by Ansimag to be defective in material or workmanship will be repaired or replaced at Ansimag's option as the exclusive remedy.

Limitation of liability

To the extent allowable under applicable law, Ansimag's liability for consequential damages is expressly disclaimed. Ansimag's liability in all events is limited to and shall not exceed the purchase price paid.

Warranty disclaimer

Ansimag has made a diligent effort to illustrate and describe the products in this literature accurately; however, such illustrations and descriptions are for the sole purpose of identification and do not express or imply a warranty that the products are merchantable, or fit for a particular purpose, or that the products will necessarily conform to the illustration or descriptions.

Except as provided below, no warranty or affirmation of fact, expressed or implied, other than as stated in "LIMITED WARRANTY" is made or authorized by Ansimag.

Product suitability

Many states and localities have codes and regulations governing the sale, construction, installation and/or use of products for certain purposes, which may vary from those in neighboring areas. While Ansimag attempts to assure that its products comply with such codes, it cannot guarantee compliance, and cannot be responsible for how the product is installed or used. Before purchasing and using a product, please review the product application as well as the national and local codes and regulations, and be sure that product, installation, and use complies with them.

Warranty exclusions

Wear items that must be replaced on a regular basis are not covered under this warranty. Such items include, but are not limited to mouth rings, thrust rings, O-rings, bushings and shafts.

Items that have been subject to extreme heat or have been used with abrasive or incompatible chemicals are not covered under this warranty.

EC Declaration of Conformity

Manufacturer: Sundyne Corporation

Details of Equipment:

Model Prefix	Alternative Model Description	Description	Harmonized Standards applied in order to verify compliance to the Directive
KF	ALA (PR, PS, QS, QT Couplings)	Magnetic Drive Sealless Centrifugal Pumps	MACHINERY DIRECTIVE 98/37/EEC: EN 292-1 Safety of Machinery - Basic Concepts, general principles of design. EN 292-2/A1 Technical principles and specifications (and amendment 1). EN 809 Pumps and pump units for liquids – Common Safety Requirements. ATEX DIRECTIVE 94/9/EC: EN 13463-1 Non-Electrical equipment for potentially explosive atmospheres. Part 1: Basic method and requirements. EN 13463-5 Non-electrical equipment Part 5: Protection by constructional safety 'c'.
KF	ALI (PR, PS, QS, QT Couplings)		
K	ALA (A, B,C Couplings)		
K	ALI (A, B, C Couplings)		
KM	ALA (AA, AB Couplings)		
KM	ALI (AA, AB Couplings)		
KV	VALA		
KV	VALI		
KP	SPALA		
KP	SPALI		

Directives to which the above equipment complies to:

Machinery Directive

Directive relating to Machinery (98/37/EC)

ATEX Directive

Directive on equipment and protective systems intended for use in potentially explosive atmospheres (94/9/EC)

Group II Categories 2 and 3 (gas)

Notified body:

Intertek Testing and Certification Ltd

Intertek House
Cleeve Road, Leatherhead,
Surrey, KT22 7SB
UK

Certification Numbers:

ITS03ATEX11180

ATEX Technical Construction File Number:

ATEX-ANSIMAG-001

Year in Which CE Mark was affixed:

1996

We certify that Plastic Lined magnetically driven bareshaft, close-coupled, and separately mounted pumps manufactured by the Sundyne Corporation meet the requirements of the above Directives, when installed, operated and maintained in accordance with our published Installation and Operating Manual. Plastic Lined magnetic drive pumps must not be put into service until all the conditions relating to safety noted in these documents have been met.

Authorised Signatories on behalf of Sundyne Corporation:

Name: Jeff Wiemelt

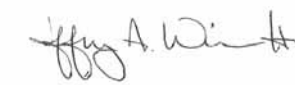

Position:

Vice President and General Manager of Sundyne Corporation, The Americas

Name: Kerry Kramlich



Position:

Pump Engineering Manager

Date of issue: 16th June 2003

Place of Issue: United Kingdom

SAFETY WARNING

Genuine parts and accessories have been specifically designed and tested for use with these products to ensure continued product quality and performance. Testing cannot be performed on all parts nor on accessories sourced from other vendors, incorrect design and/or fabrication of such parts and accessories may adversely affect the performance and safety features of these products. Failure to properly select, install or use authorised Sundyne parts and accessories is considered misuse, and damage or failure caused by misuse is not covered by Sundyne's warranty. Additionally, modification of Sundyne products or removal of original components may impair the safety of these products and their effective operation.

EUROPEAN UNION MACHINERY DIRECTIVE (CE mark system)

This document incorporates information relevant to the Machinery Directive 98/37/EC. It should be read prior to the use of any of our equipment. Individual maintenance manuals which also conform to the EU Directive should be read when dealing with specific models.

EUROPEAN UNION ATEX DIRECTIVE



This document incorporates information relevant to the ATEX Directive 94/9/EC (Directive on equipment and protective systems intended for use in potentially explosive atmospheres). It should be read prior to the use of any of our equipment.

Compliance to the Directive is based on Atmospheres having pressures up to but not exceeding 350psi and temperatures ranging from -120 °F to + 250 °F depending on the model.

As indicated in the ATEX Directive 94/9/EC, it is the responsibility of the user of the pump to indicate to Sundyne Corporation the Zone and Corresponding group (Dust or Gas) that the pump is to be installed within. Should the pump be put into service in a potentially explosive atmosphere, the user of the pump must put the grounding connector into use.

CAUTION

Read all instructions before removing pump from shipping container or preparing it for operation. It is important to install and operate the pump correctly to eliminate any possible mishap that may be detrimental to property or personnel. Keep this manual for future reference.

2. PUMP IDENTIFICATION

Every pump and wet end only unit shipped has a serial number, model number, and code number stamped on a stainless steel identification tag. This plate is riveted on a bracket or casing. Please confirm all information stamped on the plate as soon as pump is received. Any discrepancy between the order and the information stamped on plate must be reported to your local dealer. If pump is purchased with a factory supplied motor, the motor nameplate must also be checked to verify motor's compatibility

with pump and with order. Pay special attention to voltage, HP, RPM, and frequency information. Maintenance instructions in this manual are based on K Series ANSI and ISO models equipped with NEMA or IEC motors. Because Ansimag keeps permanent records for all pumps by serial number, this number should be included with all correspondence. The model number, including impeller diameter (in inches), together with the code number and the mounting code number define the type of pump in detail.

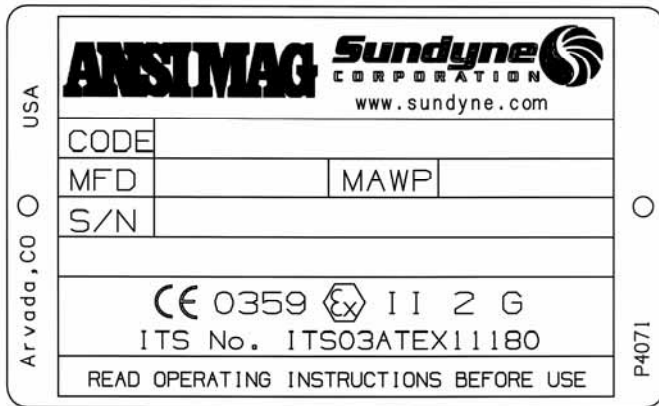

Fig. 2-1 Name Plate

PUMP CODE K+ 1516 C 02 AK 1 1 1 1 1 A

SERIES	
K+ Series	K+

HYDRAULICS		
NEMA	ISO	JIS
1516	i32160	j40160
1518	i32200	j40200
3156	--	--
3158	i40200	j50200
326	i50160	j50160
326S	--	--
436	i65160	j65160

CONFIGURATION	
Close Couple	C
Long Couple	L
Wet End	W
Cartridge	NC

MOTOR FRAME			
NEMA		IEC, JIS	
Wet End Only	00	80 IEC & JIS	30
56C	01	90 IEC & JIS	31
143/145TC	02	100/112 IEC & JIS	32
182/184TC	03	132 IEC & JIS	33
213/215 TC	04	160 IEC & JIS	34
254/256 TC	05		
284/286 TSC	07		
324/326 TSC	09		

DRIVE SIZE	
AK – 10 hp	AK
BK – 15 hp	BK
CK – 30hp	CK

O-RING	
Viton	1
EPDM	2
GORTEX	4

WEAR PARTS	
SIC / CFR-PTFE	1
SIC / SIC	2
Carbon / CFR - PTFE	3
Carbon / SIC	4

WETTED MATERIAL	
CFR -ETFE	1
GFR – PFA	2
ETFE w/ PFA Impeller	4

PUMP CASE MATERIAL	
CI / ETFE	1
CI / GFR-PFA	3
316 SS	4
Hastelloy® B	5
Hastelloy® C	6

PUMP CASE FLANGE	
150	1
300	2
ISO PN 16	3
JIS 10	4

THIRD PARTY CERTIFICATION	
None	0
ATEX / CE	A

Notes: A. Gortex® PTFE encapsulated Viton with a Gortex® wrap.
 B. Wear Parts Material is shaft material/bushing material.
 C. Pump Case Material is base material/lining. Hastelloy and 316SS is unlined.

3. SAFETY CHECK LIST

- ☑ **Warning! Magnetic Field Hazard.** Magnetic drive pumps contain some of the world's strongest magnets. These magnets are located in the impeller and outer drive magnet assemblies. The powerful magnetic fields could adversely affect persons who are assisted by electronic devices that may contain reed switches, and these people should not handle magnetic pumps or their parts. Pacemakers and defibrillators are examples of these devices.

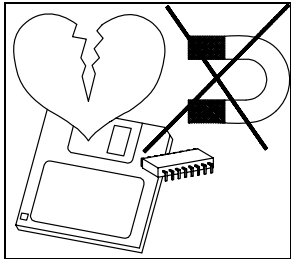

Magnetic Field Hazard

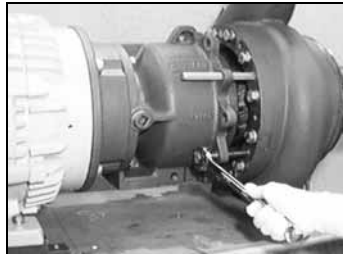

DO Use jackscrews



DON'T use hands!

- ☑ **Warning! Magnetic Forces Hazard.** Use only the recommended disassembly and assembly procedures when separating the wet end from the drive end. These procedures are found in Sections 7-a and 8-a. The magnetic forces are strong enough to abruptly pull the drive end and wet end together. Be very careful to keep fingers away from mating faces of wet end and drive end to avoid injury.
- ☑ **Warning! Hot Surfaces Hazard.** These pumps are designed to handle liquids at temperatures up to 250°F and will become hot on the outside. This creates a hazard of burns to personnel coming in contact with the equipment.
- ☑ **Warning! Rotating Parts Hazard.** The pump contains parts which rotate during operation. Before operation the pump must have the coupling guard secured in place and be completely assembled. To prevent injury during maintenance the pump and/or driver must be disconnected and locked out from the power source. Local safety standards apply.
- ☑ **Warning! Chemical Hazard.** The pumps are designed to handle all types of chemical solutions. Many are hazardous to personnel. This hazard could take the form of leaks and spills during maintenance. Plant procedures for decontamination should be followed during pump disassembly and part inspection. Keep in mind there is always the possibility of small quantities of liquid being trapped between pump components.
- ☑ **Caution! Magnetic field sensitive items.** Do not put **magnetic field sensitive items** such as credit cards, floppy diskettes or magnetic tapes near the impeller or drive magnet assemblies.
- ☑ **Caution! Magnetic Tools.** Do not use steel or iron tools near magnets. Steel tools such as wrenches and screwdrivers are easily attracted to magnets and can break them on contact.

4. PRINCIPLES OF MAGNETIC DRIVE PUMPS

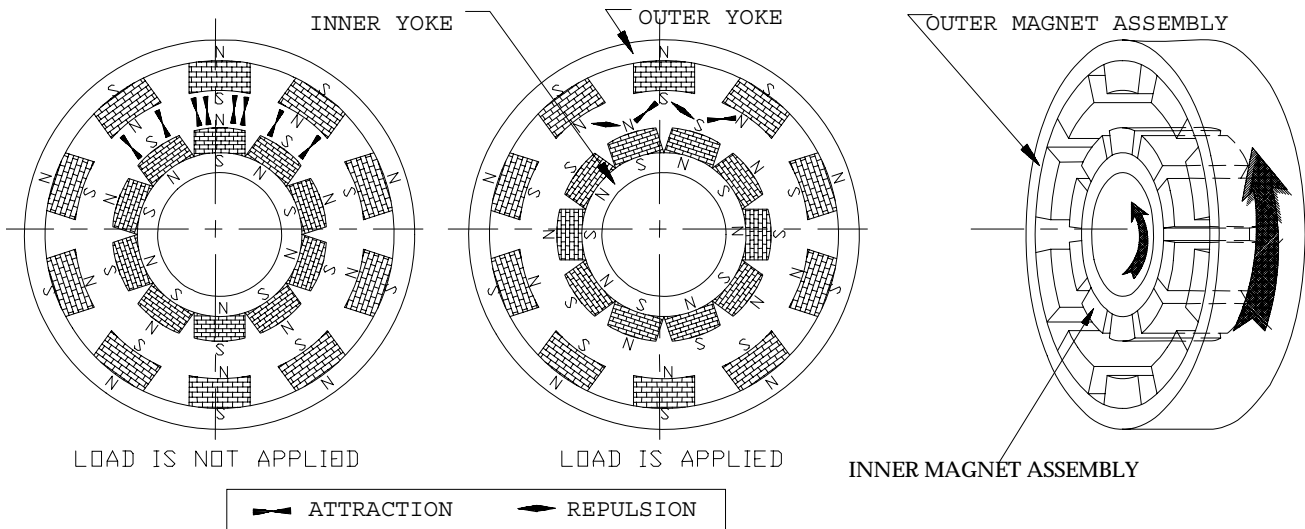

Fig. 4-1

A magnetic coupling consists of two magnet assemblies. One is the outer assembly (the driver magnet) and the other is the inner assembly (the driven magnet). The outer assembly is connected to a motor and the inner assembly is indirectly or directly attached to a pump impeller. As Figure 4-1 shows, at rest, magnet components of the outer assembly are aligned with their counterparts in the inner assembly. When load (torque) is applied, the coupling deflects angularly and the magnets create a force of simultaneous attraction and repulsion. This force is used to transfer torque from the motor to the impeller.

This **permanent-permanent magnet coupling** creates neither slippage nor induction currents during rotation. If excessive torque is applied, the magnets will de-couple. The magnets will not re-couple unless the pump is stopped. There is no energy loss in this permanent-permanent coupling unless an electrically conductive containment is placed between the outer and inner magnets. If an electrically conductive material is used for the containment, eddy-currents will be generated which will cause some energy loss. **Ansimag's K+ Series pumps use only non-conductive containment shells.** Ansimag's K+ Series pumps have an inner magnet assembly which is indirectly attached to the impeller (CFR/ETFE) or directly molded into the impeller (GFR/PFA). The magnets are shown in Figure 4-2 behind the impeller.

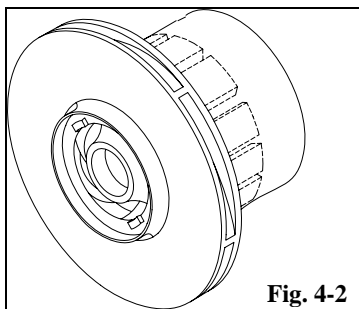

Fig. 4-2

5. PUMP INSTALLATION

5-a. PIPING

1. Install the pump as close as possible to the suction tank. Pumps are designed to push, not pull, liquid.
2. Ansimag recommends supporting and restraining both the suction and discharge pipes near the pump to avoid the application of forces and moments to the pump casing. All piping should line up with the pump flanges naturally to minimize any bending moments at the pump nozzles.
3. To minimize friction the suction line should have a short straight run to the pump, and be free of fittings, for a length equivalent to or larger than ten (10) times its diameter.
4. The suction line size should be at least as large as the pump's suction port or one size larger if the suction line is so long that it significantly affects NPSH available. **Never reduce the suction piping size.**
5. The suction line should have no high points since these can create air pockets.
6. The NPSH available to the pump must be greater than the NPSH required. Screens and filters in the suction line will reduce the NPSH available, and must be considered in the calculations.
7. **Caution: Do not install a check valve in the suction line even if a check valve is installed in the discharge line. The suction line check valve could shut off before the discharge line check valve closes. This would cause water hammer, which may burst the rear casing /containment shell.**
8. The discharge piping should be equal in size to the pump outlet port.
9. A stop valve and a check valve should be installed in the discharge line. The stop valve is used when starting and stopping the pump, and to isolate the pump for maintenance. It is advisable to close the stop valve before stopping the pump. The check valve will protect the pump from water hammer damage. These recommendations are especially important when the static discharge head is high.

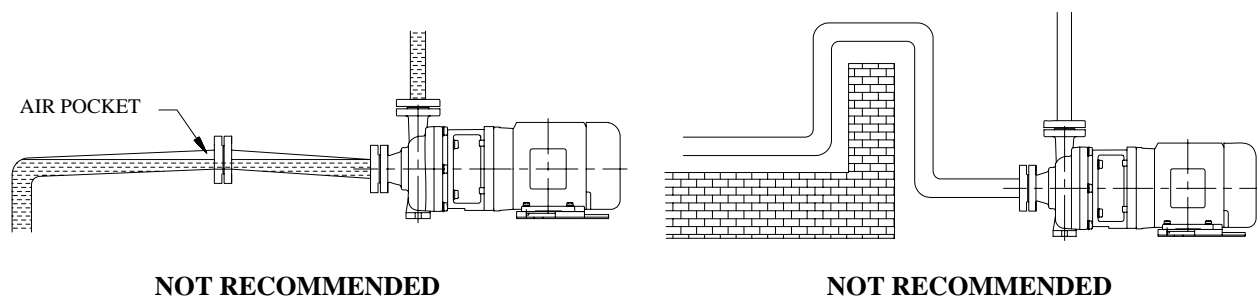
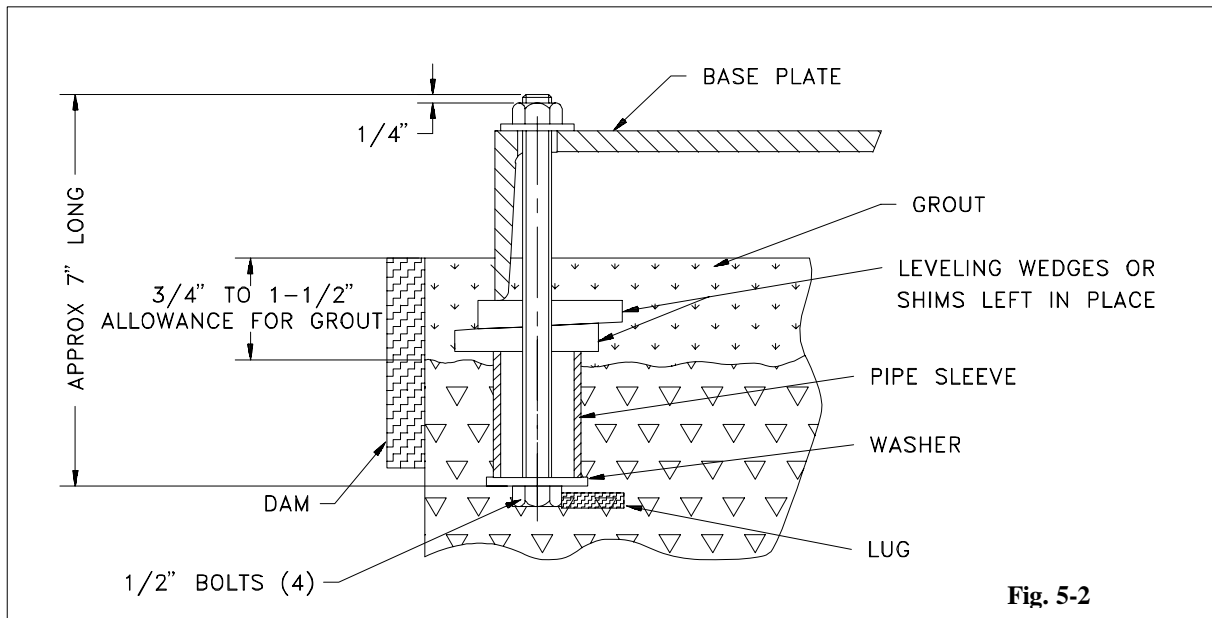

Fig. 5-1: Pump Installations

5-b. FOUNDATION



1. The foundation should be sufficiently substantial to absorb vibration and form a permanent, rigid support for the base plate. This is essential for maintaining alignment of a long coupled unit. A concrete foundation should be satisfactory. Embed foundation bolts of the proper size (1/2" -13 x 7" recommended for ordinary installation) in the concrete, located by a drawing or template. Use a pipe sleeve larger than the bolt to allow enough base movement for final positioning of the bolts.
2. Support the base plate on rectangular metal blocks and shims, or on metal wedges with a small taper. Place the support pieces close to the foundation bolts. A spacing of 24" is suggested. Allow a gap of 3/4" to 1-1/2" between the base plate and the foundation for grouting.
3. Adjust the metal supports or wedges until the shafts of the pump and driver are level. Check the horizontal or vertical positions of the coupling faces as well as the suction and discharge flanges of the pump by means of a level. Correct the positions, if necessary, by adjusting the supports or wedges under the base plate as required.
4. When alignment is correct, tighten foundation bolts evenly but not too firmly. The units can then be grouted to the foundation. The legs of the base plate should be completely filled with grout and the leveling pieces, shims, or wedges should be grouted in place. The foundation bolts should not be tightened until the grout is hardened, usually about 48 hours after pouring.

Never operate the pump without first securing it into position.

5-c. INSTALLATION AND ELECTRICAL CONNECTIONS

Ansimag K Series pumps are easily inspected without removing the casing from any piping, by separating the drive end from the wet-end. In a close-coupled pump this requires moving the motor, drive magnet and bracket backwards and away from the casing. To be able to do this the motor must have sufficient clearance behind the motor fan cover to move the motor backward approximately 6" [150 mm]. Close-coupled installations should feature the following:

1. Allow at least 6" [150 mm] of clearance behind the motor.
2. The base plate under the motor must be flat and long enough to allow for safe movement of the motor.
3. The motor electrical wiring should include a flexible section near the motor to allow movement of 6" for servicing of the pump without disconnecting piping. The recommended installation is illustrated in Figure 5-3.

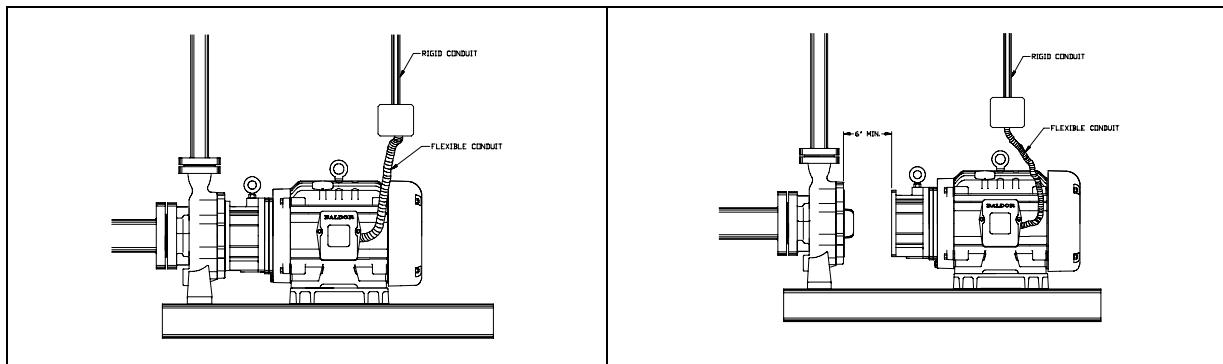

Fig.5-3: Flexible Electrical Connection on the Motor

5-d. EARTHING ARRANGEMENT

Pumps that have been supplied in accordance to the ATEX Directive (94/9/EC) will be identified by a label with the following symbol on it:



Such units are supplied with an earthing ground lug that is attached by a M6 screw (60-70 in-lb) and a lock washer (kit, P4107) to the bracket. Once the unit is installed and leveled, it should be wired to earth with a suitable earthing cable.

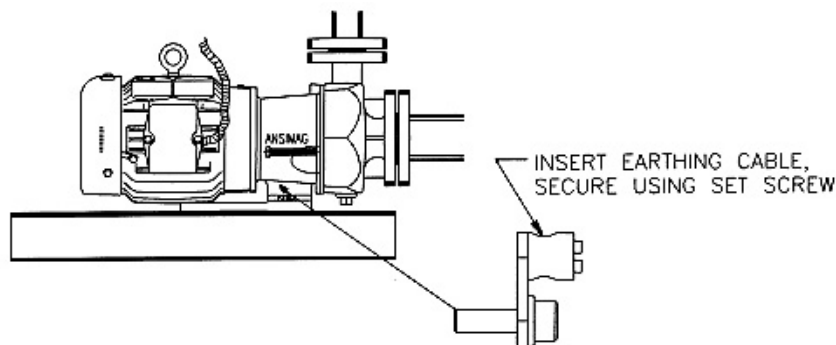

Fig. 5-4: Earthing Arrangements

6. PUMP START UP AND SHUTDOWN

6-a. PRE-START CHECKLIST

Before initial start up and after inspections of the wet end of pump, perform the following inspections:

1. Manually turn the motor fan or flexible coupling to insure that it rotates freely. For a motor mounted directly to the pump (close coupled), insert a screwdriver or other tool through the fan cover and rotate the fan. It should **rotate freely**.
2. Make sure that the **pump is full of liquid** and the suction valve is open.
3. Fully open the discharge valve once and then close it, so that any air trapped in the pump and suction line can be purged.
4. Check all electrical connections with a wiring diagram. Make sure that the voltage, frequency and horsepower on the motor nameplate match the line circuit.

Caution!: K Series horizontal end suction models are not self-priming pumps! The pump must be filled with liquid by gravity from a flooded suction tank or primed by other methods such as injecting liquid from an outside source into the pump and suction line with an attached foot valve.

6-b. START UP AND OPERATION

1. With the pump full of liquid, check motor rotation by jogging pump and motor for about 1/2 second. The proper rotation is clockwise as viewed from the motor fan end. Once proper motor rotation is confirmed jog 5 or 6 times more. This process is very important to **fully wet sleeve bushing and pump shaft**, and to purge some of the air trapped in the pump and discharge line. Open the discharge valve once and close it again so that more air can be released downstream.
2. Turn the pump on. **Open the discharge valve slowly**. It is important to open the valve very **slowly**. Sudden opening of the valve while air is trapped between the pump and the valve may cause water hammer.
3. Keep the suction valve fully opened. **Do not use the suction valve to adjust flow rate. Adjust the flow rate with the discharge valve only.**
4. Subsequent pump starts do not require motor jogging or valve position changes provided that the piping and pump has remained full of liquid.

Caution! Do not run the pump dry. The pump may be severely damaged. The pumps use slide bearings that are lubricated by the pumped product. No lubrication, no bearings. Even short periods of dry running could damage the pump.

Caution! Do not Dead Head. Although the radial loads on the bearings are not a concern, the liquid in the pump will rapidly increase in temperature. This will continue until the boiling point is reached. Some liquids boil at temperatures sufficient to melt pump components and destroy the magnets. Other liquids will flash into vapor. This vapor collects at the bushing causing dry running.

Caution! Mag Drive Mismatch. Do not use inner and outer magnet assemblies with unlike drives (AK with BK, CK with AK, etc.). Mismatch of drives will prevent coupling from occurring and **will damage** the pump. Typically, the pump will make a loud buzzing noise with little or no flow and head developed.

Caution! Cavitation. Prolonged cavitation may cause pitting on the pump components. Short term severe cavitation, such as that caused by a closed suction will damage the pump bearings.

Caution! Water Hammer. Sudden changes in fluid velocity can cause large, rapid pressure surges. These pressure surges can damage the pump, piping and instrumentation. Typical causes are rapidly closing valves. Check valves on the suction can also cause water hammer if the liquid has time to reverse direction before the valve closes.

Recommended! Power Monitors. We recommend installing a Sundyne power monitor on all pumps. These devices are very effective at protecting the pumps from dry running, cavitation or when frequent overload is expected. They are also very effective for stoppage during tank unloading applications.

- Dry Running
- Closed Valve
- Clogged Suction Filter
- Pump Seizure
- Severe Cavitation
- Excess (High) Flow

6-c. SHUTDOWN

If the pump is to be shut down for any reason, use the following procedure:

1. Close the discharge valve slowly to prevent water hammer.
2. Shut off the motor.
3. Close the suction valve.

Safety

TEMPERATURE CLASSIFICATION - (ATEX DIRECTIVE 94/9/EC)

The maximum surface temperature of a metallic magnetic drive pump is the **highest** temperature ascertained from any one of the following conditions:

1. The temperature of the pumped liquid, plus 20°C.
or
2. The ambient temperature plus 20°C.
or
3. The ambient temperature plus 39°C (only in the case of separately mounted pumps with oil lubricated bearing assemblies)
or
4. The temperature of the heating medium being used in the heating jacket (if fitted)

The actual classification is calculated by obtaining the maximum surface temperature and then using the following table to obtain the relevant Temperature Class:

Temperature Class	Maximum Surface Temperature (°C)
T1	450 (842°F)
T2	300 (572°F)
T3	200 (392°F)
T4	135 (275°F)
T5	100 (212°F)
T6	85 (185°F)

Example:

The pump is pumping a liquid with a temperature of 120°C. The pump is close coupled and therefore does not have an external oil lubricated bearings. The maximum ambient temperature in which the pump may operate is 30°C

Condition 1 equates to $120^{\circ}\text{C} + 20^{\circ}\text{C} = 140^{\circ}\text{C}$

Condition 2 equates to $30^{\circ}\text{C} + 20^{\circ}\text{C} = 50^{\circ}\text{C}$

Condition 3 does not apply.

Condition 4 does not apply.

Thus the maximum surface temperature of the pump is 140°C which equates to a temperature classification of T3.

7. DISASSEMBLY AND MAINTENANCE

WARNING! Before disassembly, the pump must have the drive "locked out" and be flushed of all dangerous liquids. **Follow all Federal, State, Local and company regulations with regard to pump decontamination prior to disassembly and inspection.** Ansimag K Series pumps are provided with a low point casing drain to maximize pump decontamination.

Both the long coupled and close coupled K Series pumps can be pulled back from the casing. Therefore, if permitted by company regulations, pump disassembly and inspection can be conducted on site.

Before inspecting, be sure to have a spare casing O-ring on hand to reinstall after the inspection is completed.

7-a. BASIC DISASSEMBLY FOR INSPECTION

1. Stop the pump, lock out the pump starter, shut off all the valves connected to pump, and drain and decontaminate the pump. **Warning! Be sure pump is flushed of dangerous or hazardous liquids and all internal pressure is relieved before opening the pump for inspection.**

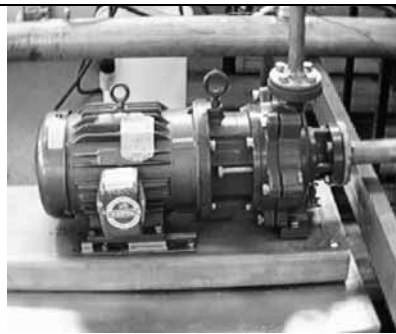

Fig. 7-1: K Series Pump

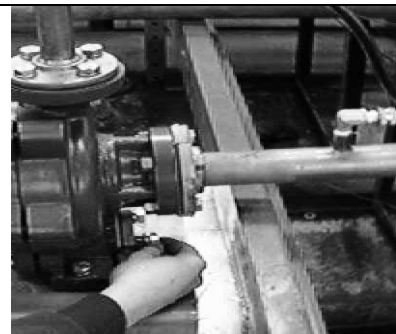

Fig. 7-2: Casing Drain

2. Remove the bolts securing the motor and/or the bracket to the base. Remove the bolts securing the pump bracket to the rear support.

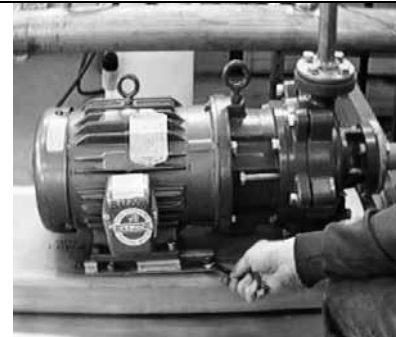

Fig. 7-3: Unbolt from Base

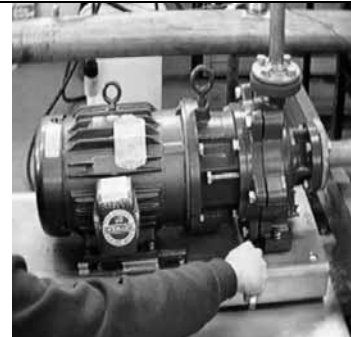

Fig. 7-4: Unbolt Bracket from Rear Support

3. Use the jackscrews to separate the motor and pump drive end at least 6" [150 mm] back from the pump wet end.
Caution! Cantilevered mounts require that the motor fan end be supported.
Caution! You are separating the magnet coupling.
LONG COUPLED PUMPS: Remove coupling guard and coupling. Remove bolts securing pump-bearing frame to rear support. Pull bearing frame back from pump wet end.
Caution! You are separating the magnet coupling.



Fig. 7-5: Use Jackscrew to Pull Motor Back

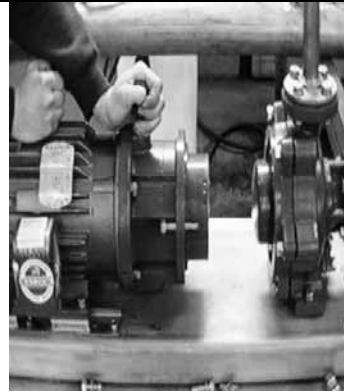

Fig. 7-6: Motor Separated 6" from Pump Wet End

4. Remove bolts (6 or 8) securing the rear support to the pump casing. Carefully pull back the rear support and containment shell unit.
Caution! Wear protective clothing, eyewear and gloves as required for the pumped liquid.
Caution! The impeller assembly contains very powerful magnets. Keep impeller separated from magnetic tools and structures.

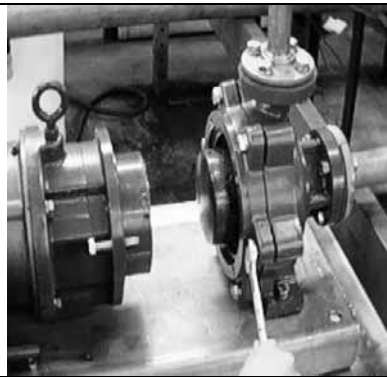

Fig. 7-7: Unbolt Rear Support from Pump Casing

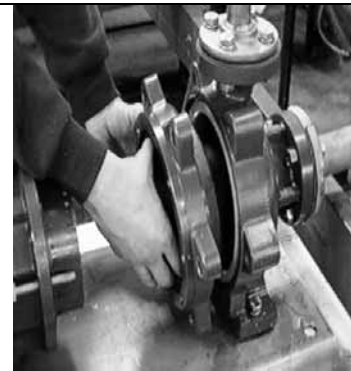

Fig. 7-8: Remove Rear Support

5. The impeller and shaft may come with the containment shell or remain in the pump casing. Remove the impeller from the casing. Remove the shaft from the impeller.
Caution! If the shaft is dropped on a hard surface such as concrete the impact may cause the shaft to break.

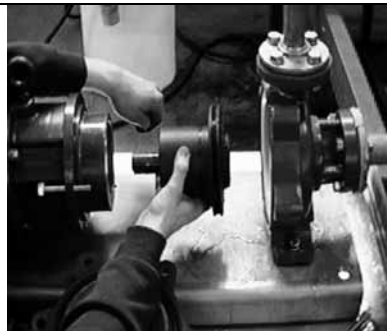

Fig. 7-9: Remove Impeller from Pump Casing OR ...



Fig. 7-10: Remove Impeller from Containment Shell

7-b. INSPECTION CHECKLIST

Since most wearing parts on a mag drive pump cannot be monitored, it is important to inspect the pump for wear after the initial 500 hours or three months of operation, whichever comes first. Inspect again in six or twelve months, depending on the results of the first inspection.

Before inspecting, be sure to have a spare casing O-ring on hand to reinstall after the inspection is completed. To inspect the pump interior, be sure that the pump has **first been flushed of all dangerous liquids**.

Operating conditions vary so widely that recommending one schedule of preventive maintenance for all centrifugal pumps is not possible. In the case of magnetic drive pumps, particularly of non-metallic pumps, **traditional maintenance techniques such as vibration monitoring are not useful or reliable for wet end preventive maintenance**. These techniques are effective only for bearing frames (non-liquid contact components) and for motor bearings. For best maintenance results, keep a record of actual operating data such as flow, pressure, motor load, and hours of operation. The length of the safe operation period will vary with different applications and can be determined only from experience.

The inspection checklist is as follows:

1. Check for cracks in **silicon carbide parts** such as the thrust ring and shaft.
2. Check for signs of melting or deforming in the **shaft support, bushing** and the **socket of the containment shell** where the pump shaft is held. Dry-running during initial startup or during operation may cause heat-related deflection or wear of these parts.
3. Inspect the **casing liner** to be sure there are no signs of abrasion or cuts deeper than 0.05" [1.3 mm]. Liner cracks may occur if the lining is corroded or placed in an extremely cold place, or if a chemical penetrates the liner and corrodes the outside metal casing. Most liner damage can be spotted visually. To detect hairline cracks, a 15-20 KV electrostatic discharge tester is recommended, which is often used to test lined pipe.
4. The 1.25" carbon bushing should be checked for wear and scoring or grooving. The dimensions are given in Section 7-c. The 1.25" SiC bushing will not exhibit wear under normal operation. Polishing on SiC surfaces is a normal condition of running and does not require replacement. However, the inner surface must be checked for cracks, chips or scratches. Verify that the main bushing is tightly pressed into the impeller. It should be impossible to dislodge the bushing by hand. Check for signs of melting around the circumference of the **main bushing**.
5. Check the **mouth ring** face for wear. The lubrication flutes are reliable indicators of mouth ring wear. If they are not visible, it is time to replace the mouth ring. A part replacement procedure is described in Section 7-d. If a CFR Teflon® mouth ring is used and excessive wear is observed, replace it with a silicon carbide mouth ring.

Fig. 7-11

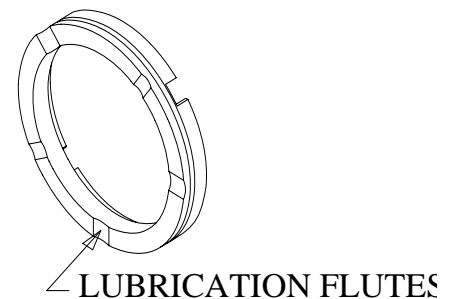

6. Check the **impeller vanes** for material trapped inside. If any of the five flow paths become clogged, a hydrodynamic imbalance may cause excessive wear to the mouth ring and main bushing.
7. Check the **inner magnet encapsulation** for cracks or grooves in excess of 1/32" [0.8mm]. Fluid inside the magnet area may cause swelling which could wear on the containment shell.
8. Check impeller and inner drive lugs for looseness or swelling due to plastic deformation. If necessary, removal of the bushing and separation of the impeller and inner drive are required to further inspect the impeller snap fit tabs and contact surfaces of the drive lugs. Replace the impeller if the snap fit tabs or drive lugs are visibly cracked or deformed. Replace the inner drive if the drive lug contact surfaces are swollen or deformed. Note: See Parts Replacement Procedures for additional instruction and tooling.
9. **Check for slurry.** If the pumped liquid contains slurry, it may build up near the back of the main bushing . This build-up may cause clogging of the journal bearing area of the main bushing and create a dry-run condition. Estimate the rate of build-up from the first inspection and schedule the unit for future maintenance accordingly.
10. Inspect the **containment shell** for signs of abrasion. Replace if scratches or grooves in the inner surface are deeper than 1/32" [0.8mm]. Also replace if the outside has grooves deeper than 0.020 [0.5mm] inches. Inspect the back **thrust ring** for chips or cracks.

7-c. DETAILED WEAR PARTS TOLERANCES

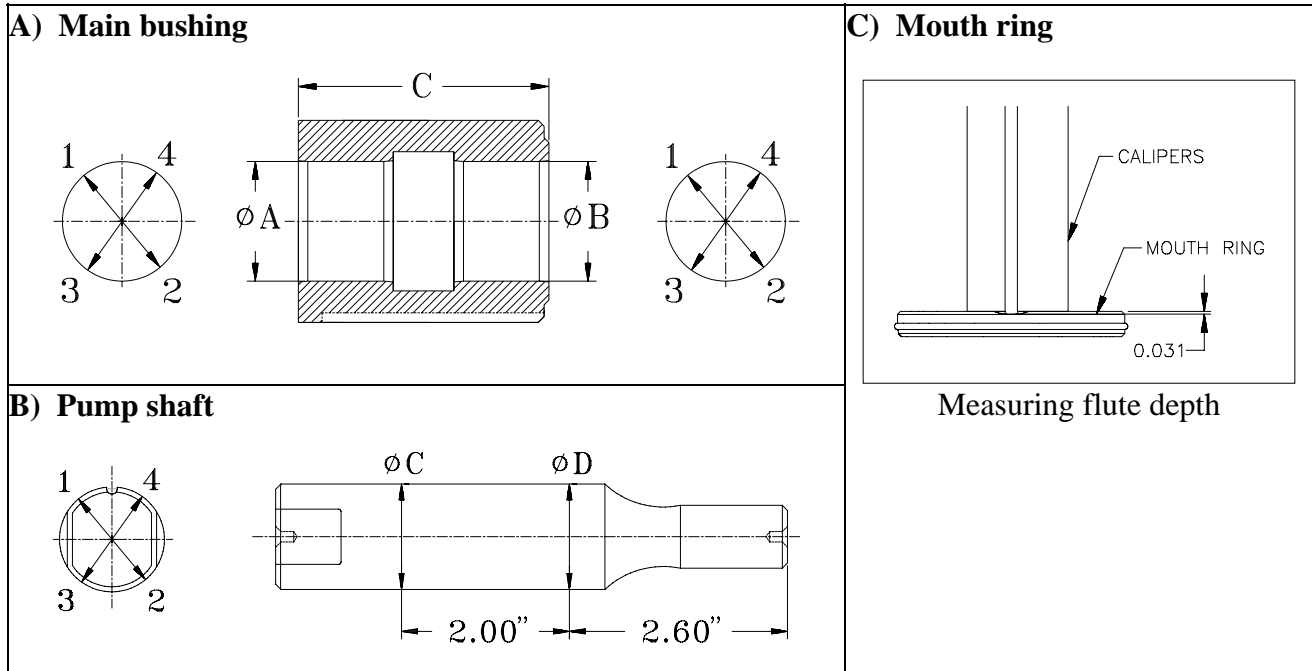

	DIMENSION	Original dimension	Date inspected			Wear Limits
			3mo./500hr		12mo./2000hr	
			/ /	/ /	/ /	
1.25" Bushings	A1-A2 Dia. (in) (mm)	1.259" dia 3.20 mm				< 1.284" dia (3.26 mm)
	A3-A4 Dia. (in) (mm)	1.259" dia 3.20 mm				< 1.284" dia (3.26 mm)
	B1-B2 Dia. (in) (mm)	1.259" dia 3.20 mm				< 1.284" dia (3.26 mm)
	B3-B4 Dia. (in) (mm)	1.259" dia 3.20 mm				< 1.284" dia (3.26 mm)
1.25" Shaft	C1-C2 Dia. (in) (mm)	1.256" dia 3.19 mm				> 1.250" dia (3.18 mm)
	C3-C4 Dia. (in) (mm)	1.256" dia 3.19 mm				> 1.250" dia (3.18 mm)
	D1-D2 Dia. (in) (mm)	1.256" dia 3.19 mm				> 1.250" dia (3.18 mm)
	D3-D4 Dia. (in) (mm)	1.256" dia 3.19 mm				> 1.250" dia (3.18 mm)
Mouth Ring	All mouth ring wear surfaces are made with grooves. These grooves provide cooling flow. When new, the grooves are 0.063" [1.60 mm] deep. The minimum groove depth is 0.031" [0.79 mm]. Replace when grooves are less the 0.031" [0.79 mm].					

* Under normal operating conditions, the shaft should last for many years. When the shaft is subjected to dry running, thermal stress cracks may develop. If cracks are found, a replacement shaft is necessary to prevent damage to other pump components.

7-d. PARTS REPLACEMENT PROCEDURES

K+ Bushing Installation/Removal Tool

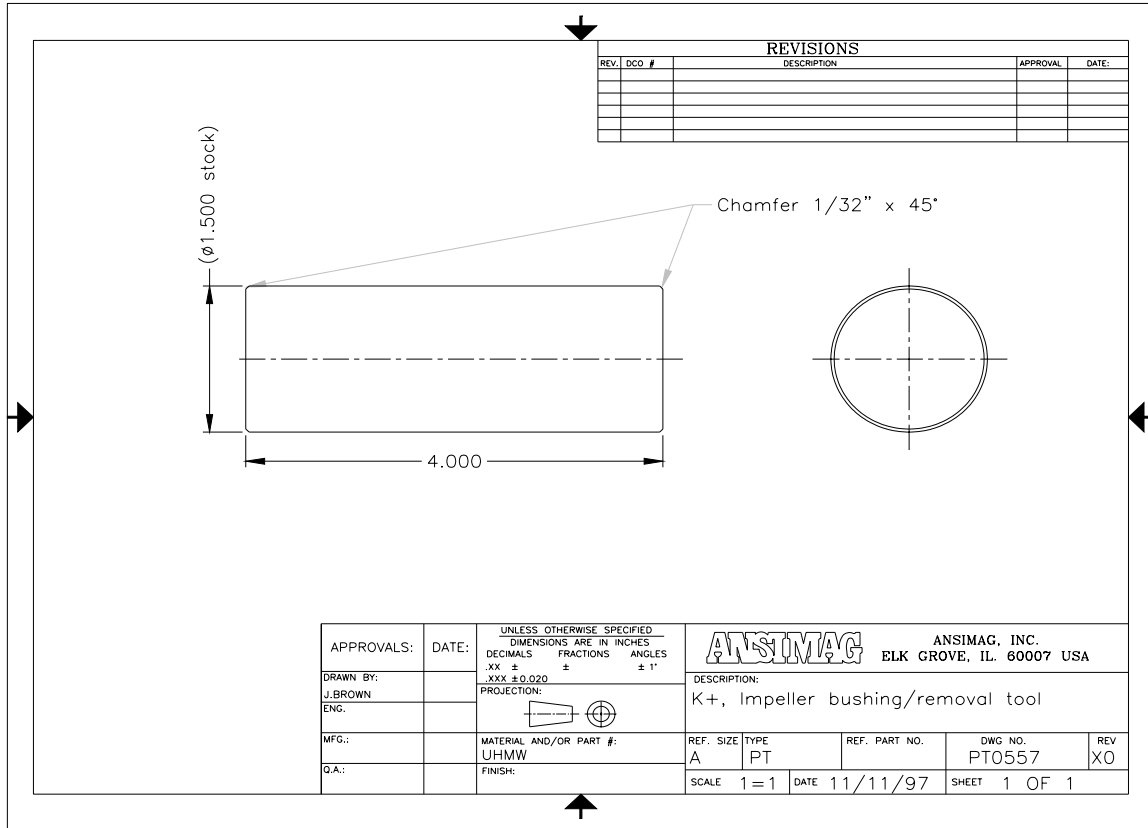

Figure 7-12: K+ Bushing/Installation Tool Drawing

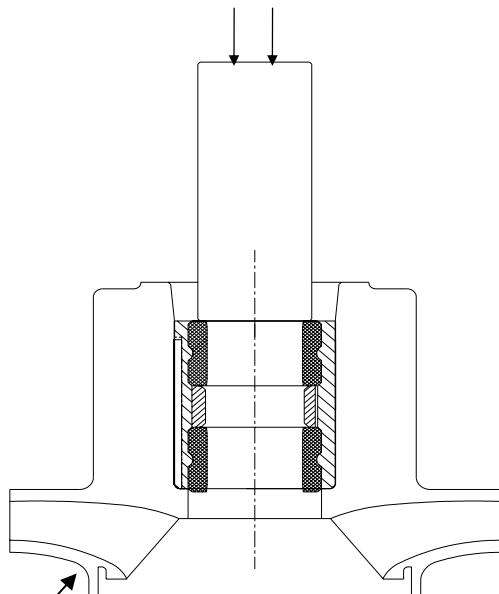

Figure 7-13a: K+ Bushing Installation

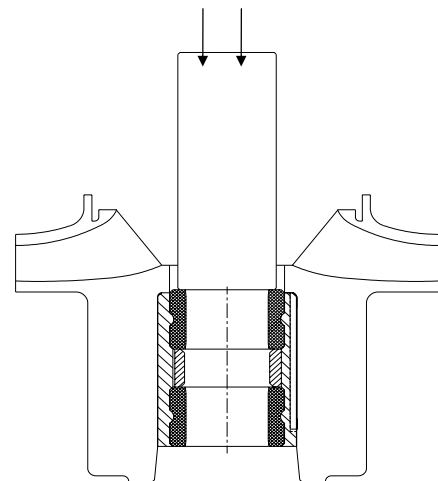

Figure 7-13b: K+ Bushing Removal

***CAUTION:** Outer diameter of impeller must be supported to avoid damage to mouth ring area during bushing installation.

1. After removing the bushing from the impeller, insert the inner drive removal tool (PT0820) into the bushing bore of the impeller. Then while holding the tool in place, drop the tool and the impeller assembly on to a hard surface from a height of approximately six inches. The gap will allow the weight of the inner drive to separate the snap fit tabs while ensuring the inner drive does not contact the hard surface. Caution: Proper use of the tool allows convenient and safe separation of the parts. (Do not pry parts apart. Prying causes damage to the plastic surfaces.)



Figure 7-14: Separation of the impeller and inner drive

2. To remove the **mouth ring** from the impeller eye use a screwdriver or other flat bladed tool. **Note:** The silicon carbide mouth rings should be removed only if inspection shows that replacement is required. **Removal is likely to damage the SiC mouth ring.**

K+ mouth ring removal



1. Cut exposed TFE O-ring.
2. Pull out the O-ring sections with pliers.
3. Carefully use screwdriver to loosen and remove.



Figure 7-15: Remove Mouth Ring

2. Removing the containment shell from the rear support is a simple process. The two components easily pull apart. Occasionally the stainless steel ring in the containment shell may stick into the rear support. If this happens, rest the rear support bolt lugs on some blocks and gently tap on the stainless steel ring using a long arbor. This will release the containment shell from the rear support **Note: 8" K+ models must be removed by tapping gently on the dome with a soft hammer.**

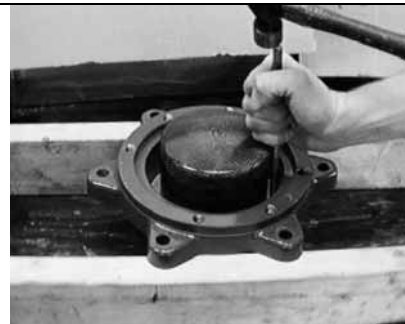

Figure 7-16: Remove Containment Shell

8. WET END ASSEMBLY (ANSI & ISO PUMPS)

8-a. SHAFT/CONTAINMENT SHELL ASSEMBLY

1. Align the two flats on the shaft with the mating flats in the containment shell. Carefully guide the SiC shaft into the containment shell. If necessary, gently drive the shaft into its socket with a soft hammer.

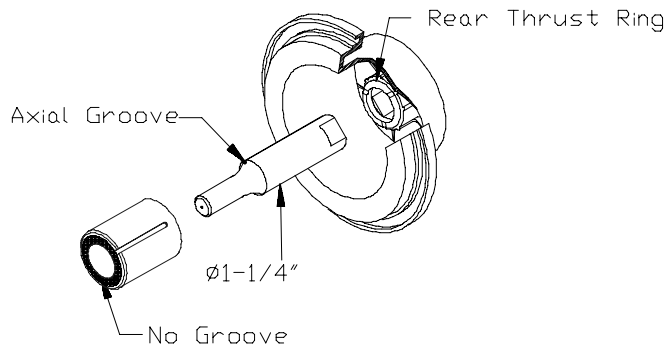

Fig. 8-1: SiC Shaft/Containment Shell Assembly

8-b. IMPELLER ASSEMBLY

1. For Impeller and Inner Drive: Align the drive lugs of the Impeller and Inner Drive and press / snap together. Use arbor press with mouth ring circular riser and flat plate, as needed. Figure 8-2. Then insert main bushing; no keyway exists.

For Impeller Assembly: Align the molded key in the impeller bore with the keyway on the main bushing. Rotate the bushing slightly until it has started onto the key. Figure 8-3.

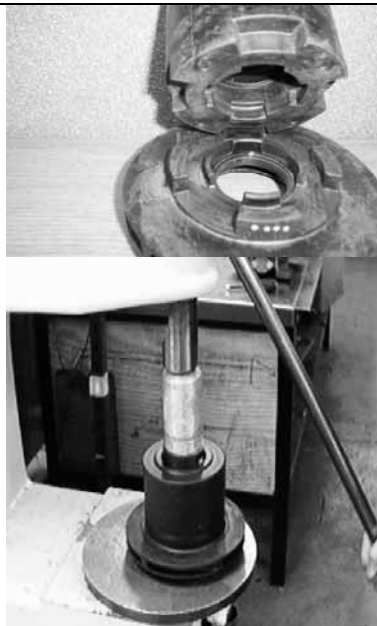

Fig. 8-2: Impeller and Inner Drive Assembly



Fig. 8-3: Line up Bushing with Keyway

2. Place the supported impeller on to the bed of an arbor press or drill press. Using tool (PT0557) press the main bushing into the impeller bore. Press until firm resistance is felt. This will position the end of the bushing approximately 0.6" [15 mm] deep.

Caution: Place impeller shroud on a circular riser to protect the lip of the mouth ring support while pressing in bushing.



Fig.8-4: Insert Bushing into Impeller with Arbor Press

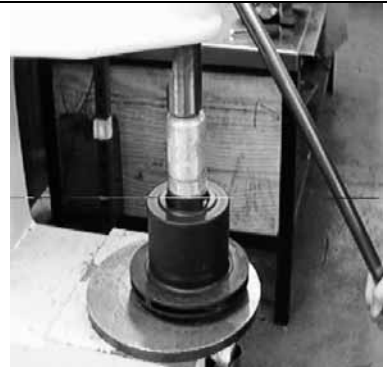

Fig.8-5: Insert Bushing into Impeller with Arbor Press

Caution: Do not use a hydraulic press, since you can not feel when the bushing hits the bottom of the bore!

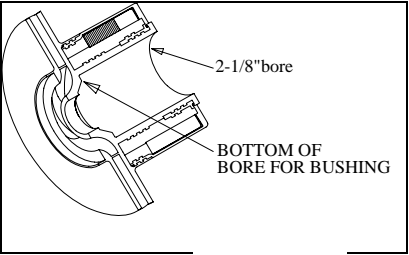

Fig. 8-6

NOTE: OLD IMPELLER MODELS have a separate key for the bushing. Place the flat side of the key into the keyway of the main bushing and line it up with the groove inside the impeller. The cone-shaped side of the main bushing fits inside the bore.

3. Align the notches on the backside of the mouth ring with the driving "dogs" on the impeller and press-fit mouth ring with O-ring attached into the mouth ring seat in the eye of the impeller. The O-ring is used as a locking ring. Model K+436, K+i65160 and K+j65160 do not require an O-ring.



Fig.8-7: Press-Fit Mouth Ring into Impeller

8-c. WET-END ASSEMBLY

1. Insert the containment shell into the rear support. It is necessary to properly align the containment shell such that the groove in the shaft is “clocked” at the 11:00 O’clock position, when viewed from the front. (On 8” models there is an arrow cast onto the backside of the rear support, to indicate the “Up” or 12:00 O’clock position. On 6” models, the rear support is clocked with the two “grooved” ears horizontal. Either of the points perpendicular to the horizontal may be chosen as the top.) If necessary tap the containment shell into place with a soft hammer until it is evenly seated.

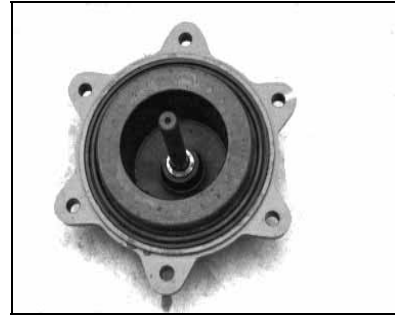

Figure 8-8: Shaft and Containment Shell in Rear Support

2. Place the impeller assembly onto the shaft. (Make sure that the main bushing and mouth ring are already installed in the impeller.)
3. Place the casing O-ring into the groove of the containment shell.
4. While holding the O-ring in place, line up the end of the shaft with the bore of the shaft- support in the pump casing and fit the two casings together.

Caution!: Ensure that the rear support is properly clocked so the shaft groove is at the 11:00 O’clock position.

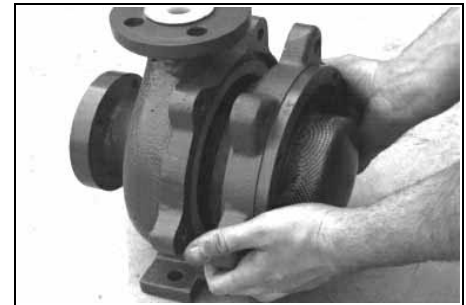

Fig. 8-9: Fit Casings Together

6. ANSI PUMPS are assembled using six 1/2"-13 x 1-3/4" hex bolts with a 3/4" wrench. Bolt the rear support onto the pump casing. Tighten the bolts to just snug at this time.
7. ISO PUMPS are assembled using six M12-1.75 x 45mm hex bolts. Bolt the rear support onto the pump casing. Tighten the bolts to just snug at this time.
8. Confirm that the impeller has some axial endplay inside the casing of about 1/16" to 1/8" [1.6mm to 3.2mm] by rocking the assembled wet end back and forth. You should hear the impeller moving inside.

Caution: If pump shaft is dropped on a hard surface such as concrete, the impact may cause to break..

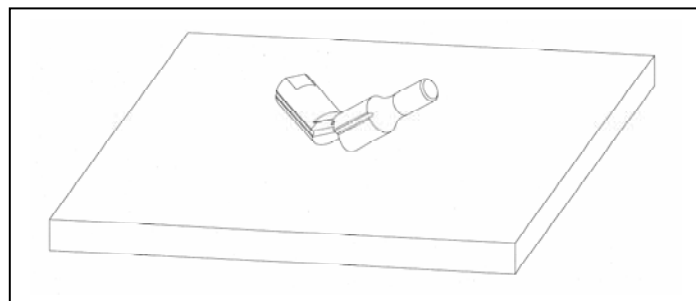

Fig. 8-10

9. DRIVE END ASSEMBLY (ANSI Pumps with NEMA Motors)

9-a. MOUNTING OUTER DRIVE TO MOTOR OR BEARING FRAME SHAFT

1. Place the motor vertically on the worktable or floor so that the shaft is pointing upwards. Be sure to cover the work surface with corrugated cardboard or similar material to prevent damage to the fan cover.
2. Place motor mounting plate(s), if required, onto the C-face of motor. Align the holes with the threaded holes on the motor. (On motor frames 143/145TC and 284TSC, the motor mounting plates bolt to the motor face holes.) See figure 9-1.
3. Place the bracket onto the motor mounting plate (or motor C face) and line up the bracket holes with holes on the motor C-face and motor mounting plate(s). Use four (1/2"-13 UNC) socket cap screws with lock washers to secure the bracket to the motor mounting plate. Tighten bolts to snug only. Note that the holes on the motor mounting plate(s) are not tapped. The plates are actually sandwiched between the bracket and the motor.
4. Back-out the two set screws on the hub of the outer drive magnet, and place the outer drive onto the motor shaft. Position the outer drive so that the groove in the outer drive lines up with the end of the bracket +1/16", -0" [+1.6 mm, -0 mm]. See Figure 9-1. Figure 9-2 shows the outer drive position with respect to the motor mounting plate for reference. Tighten the set screws to 10 ft-lb (13.6 N-m.) Install the 3/8" NPT pipe plug into the hole on top of the bracket or bearing frame. This is to keep dirt out of the motor shaft area.

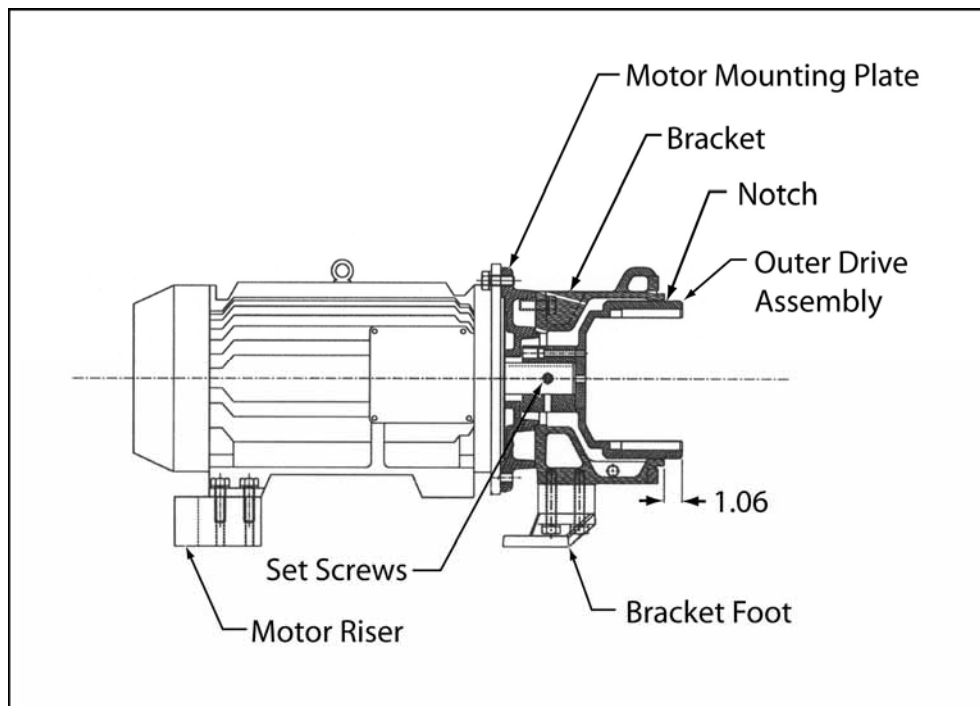

Fig. 9-1 Outer Drive Position with Respect to Bracket

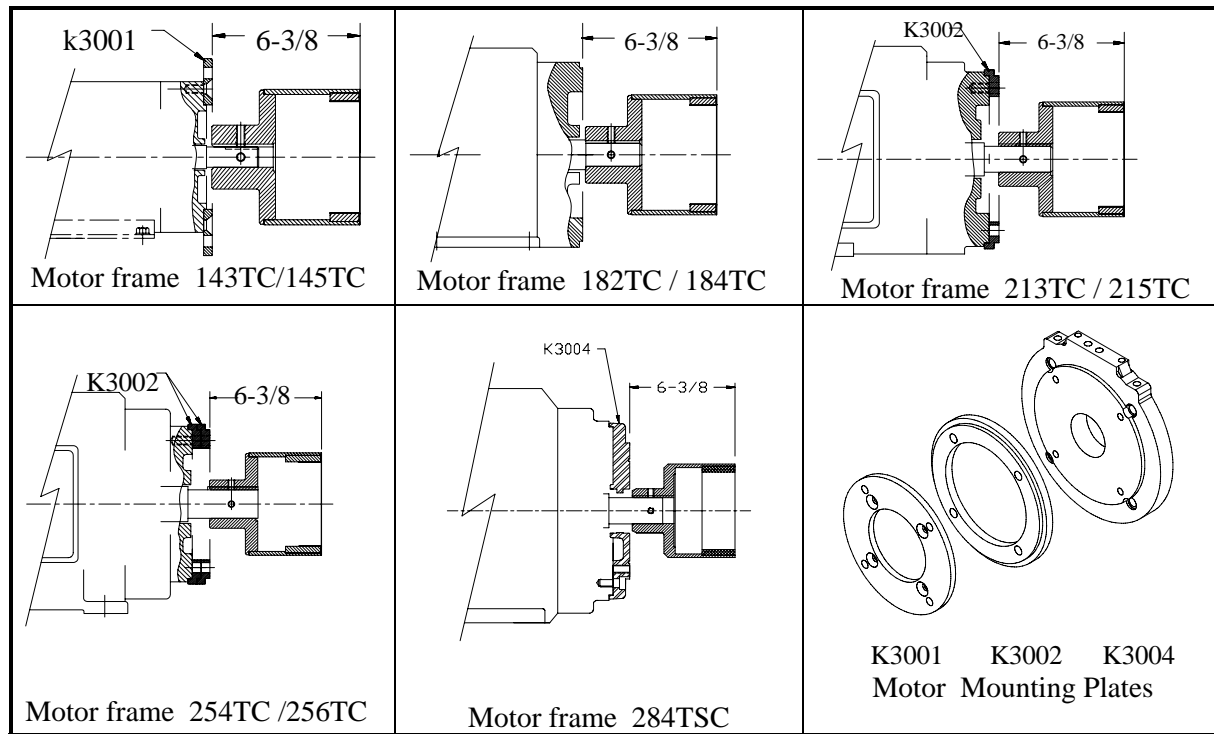

Fig. 9-2: NEMA Outer Drive Mounting Positions (Reference)

- The outer magnet ring, OMR, (P4091X) is interchangeable to maintain the outer drive mounting positions without removing the adapter hub (P4069X). After the initial installation, the outer magnet ring of the outer drive assembly can be attached to the initial adapter hub position using the two countersunk screws (02-414DJ). Tighten the screws to 60-70 in-lb using a long T handle 5/32" allen wrench. Ensure the polygon drive and mounting surfaces of the adapter hub and OMR are clean and smooth; a light oil may be used for preservation.

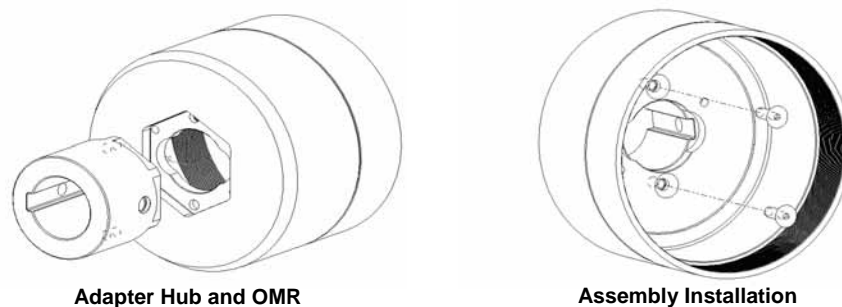
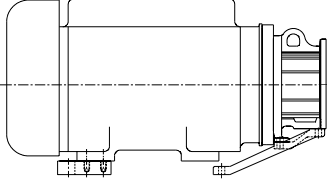
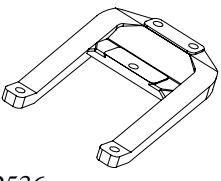

Fig. 9-3 Outer Drive Assembly

9-b. MOUNTING THE MOTOR RISERS OR FOOT

<ol style="list-style-type: none"> 1. If your pump is Group 2 ANSI (K+326, K+436 or K+3158) mount the foot to the bracket. Bolt the appropriate foot to the bottom of the bracket with 3 stainless steel bolts (1/2-13 UNC.) Torque to 40 ft-lb. Motor frames 213/215TC and larger require motor risers. 2. Group 1 ANSI pumps (K+1516, K+3156, K+326S or K+1518) do not use the bracket foot or motor risers except on 284/286TSC frames. 		 <p>P2536</p>
	<p>Fig. 9-4 Group 2 Pump</p>	<p>Fig.9-5 Motor Foot</p>

9-c. MOUNTING DRIVE END TO WET END



<ol style="list-style-type: none"> 1. Thread the two jack screws through the front flange of the bracket until they protrude as far forward as possible. 2. Line up the wet end with front of the bracket. 3. While firmly grasping the inlet and outlet flanges or the outside of the casing, carefully guide the wet end into the bracket. Retract the jack screws a few turns at a time. The strong magnetic attraction will grab the wet end when you get close enough, pulling it into the bracket forcefully. 	 <p>RECOMMENDED</p>	 <p>NOT RECOMMENDED DANGEROUS</p>
--	--	---

Fig. 9-6

CAUTION!: Be very careful to keep fingers away from mating faces to avoid injury!

9-d. Aligning Pump Mounting Feet

Set the complete pump assembly on its feet on a flat surface. Ensure that all feet are flat on the surface. This may require slightly loosening the bolts at the three piloted joints – the rear support to pump case, the bracket to rear support and the bracket to motor mounting plate. Adjust the clocking of the parts at these joints as required to get all feet to sit flat. This may require lightly tapping on any foot not in contact with the flat surface, or tapping on the parts adjacent to the joints. Re-snug all bolts. Then torque all bolts in increasing torque values in a star pattern at each joint. Final torque at all three joints is 40 ft-lb (54N-m.)

10. DRIVE END ASSEMBLY (ANSI OR ISO PUMPS WITH IEC MOTORS) (-B5 FLANGE ONLY)

10-a. MOUNTING ADAPTER, OUTER DRIVE AND FOOT

1. Place the motor vertically on worktable or floor so that shaft is pointing upwards. Be sure to cover the work surface with corrugated cardboard or similar material to prevent damage to the fan cover.
Caution!: Motors with plastic fan covers may be damaged in the vertical orientation. Perform the following assembly in the horizontal orientation.
2. Place the motor mounting plate on the motor flange. The motor mounting plate for 80 and 90 frame motors has the rectangular boss facing upwards. For the 100/112, 132 and 160 frame motors have the rectangular boss facing downwards. Bolt the motor mounting plate to the motor flange with the appropriate four bolts. See figure 10-1.
3. Place the round end of the IEC bracket onto the motor mounting plate and line up the holes. Use four 12mm X 35mm hex head bolts with lock washers to secure the bracket to the motor mounting plate. Tighten bolts to snug only.
4. Back out both of the set screws on the outer drive hub so they do not protrude into the bore. Slide the outer drive onto the motor shaft making sure that the shaft key is in place. Position the outer drive so that the groove in the outer drive lines up with the end of the bracket +1/16", -0" (+1.6mm, -0mm.) Tighten the two set screws to 10 ft-lb (13.6 N-m.) See Figure 9-1. Figure 10-1 shows the outer drive position with respect to the motor mounting plate for reference. Install the 3/8" NPT pipe plug into the hole on top of the adapter plate. This is to keep dirt out of the motor shaft area.

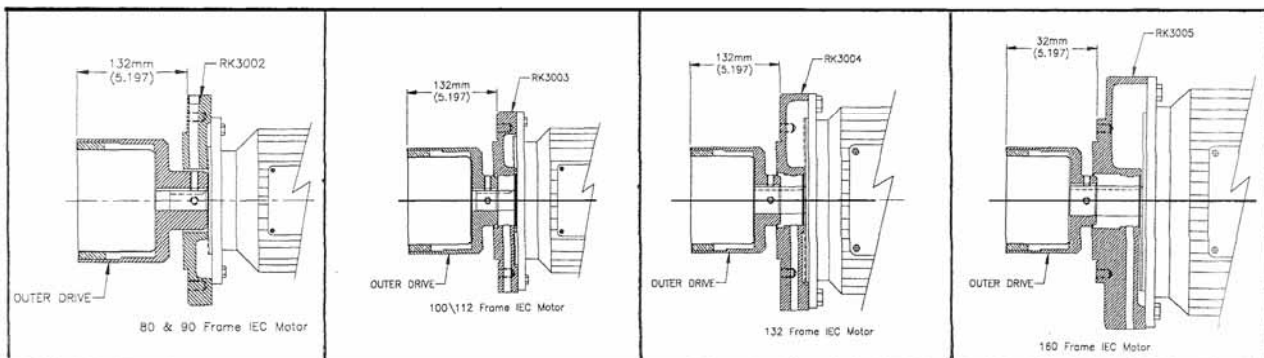

Fig. 10-1: IEC Outer Drive Mounting Positions (Reference)

- The outer magnet ring, OMR, (P4091X) is interchangeable to maintain the outer drive mounting positions without removing the adapter hub (P4069X). After the initial installation, the outer magnet ring of the outer drive assembly can be attached to the initial adapter hub position using the two countersunk screws (02-414DJ). Tighten the screws to 60-70 in-lb using a long T handle 5/32" allen wrench. Ensure the polygon drive and mounting surfaces of the adapter hub and OMR are clean and smooth; a light oil may be used for preservation.

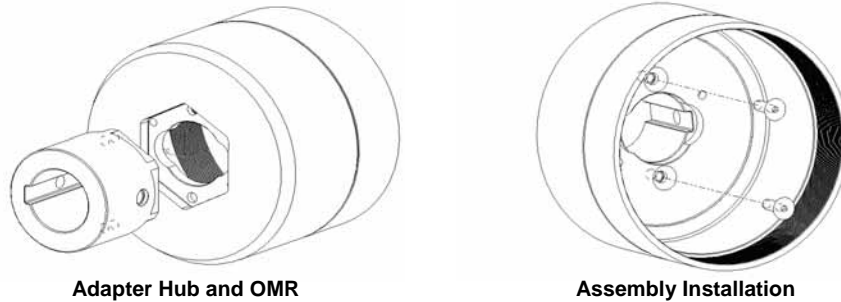

Fig. 10-2. Outer Drive Assembly

- Mount the IEC foot to the bottom of the IEC close-coupled bracket using 3, M12-1.75 hex head screws.
- Verify that the outer drive is protruding 41.5 (+1.5/-0.0) mm beyond the front edge of the close coupled bracket.

The IEC motor drive end is now ready to mount to either an ANSI or ISO wet-end.
 Note: IEC motors do not require motor risers.

10-b. MOUNTING DRIVE END TO WET END



<ol style="list-style-type: none"> Thread the two jack screws through the front flange of the bracket until they protrude as far forward as possible. Line up the wet end with front of the bracket. While firmly grasping the inlet and outlet flanges or the outside of the casing, carefully guide the wet end into the bracket. Retract the jack screws a few turns at a time. The strong magnetic attraction will grab the wet end when you get close enough, pulling it into the bracket forcefully. 	 <p style="text-align: center;">RECOMMENDED</p>	 <p style="text-align: center;">NOT RECOMMENDED DANGEROUS</p>
---	--	---

Fig. 10-3

CAUTION!: Be very careful to keep fingers away from mating faces to avoid injury!

10-c. Aligning Pump Mounting Feet

Set the complete pump assembly on its feet on a flat surface. Ensure that all feet are flat on the surface. This may require slightly loosening the bolts at the three piloted joints – the rear support to pump case, the bracket to rear support and the bracket to motor mounting plate. Adjust the clocking of the parts at these joints as required to get all feet to sit flat. This may require lightly tapping on any foot not in contact with the flat surface, or tapping on the parts adjacent to the joints. Re-snug all bolts. Then torque all bolts in increasing torque values in a star pattern at each joint. Final torque at all three joints is 40 ft-lb (54N-m.)

11. TRIMMING IMPELLERS

Assembly Instructions



Fig. 11.1



Fig. 11.2

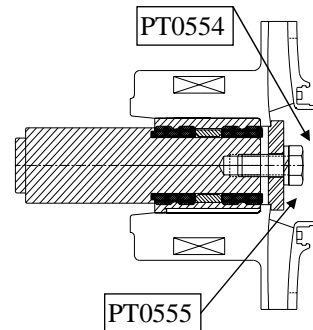

Fig. 11.3

1. Slide impeller and inner drives with lugs on to trimming tool (PT0827) and secure with support and bolt; Figure 11.1 and 11.2. For impeller assemblies, Slide K+ Impeller Trimming Tool, PT0554 (Fig. 11.3) into the bushing and tighten tension disc PT0555 with bolt. This tool will prevent lathe jaws from damaging the impeller.
2. Place the trimming tool and impeller into lathe and tighten gently, making sure to center it.
3. Adjust lathe speed to 700 RPM.
4. Slowly take roughing cuts up to 1/4" [6 mm] diameter at a time across A, B, and C as indicated in Figure 11-1. After each cut across the impeller, carefully remove all trimmed TEFZEL chips for a clean start on the next cutting approach. As you near the desired trimming diameter, take smaller and slower cuts for a smoother finish.

Unless impeller is to be trimmed to smaller than 4.50" [114 mm], proceed to steps 6 and 7.

Trimming Diameters Smaller Than 4.75" [120 mm]

5. If your impeller is to be trimmed smaller than the diameter of the sealed magnet assembly area (i.e. 4.75" [120 mm] or less), leave the back shroud (shown in Figure 11-4) at 4.75" [120 mm] diameter and proceed to trim the front shroud and vanes to desired size.
6. After finalizing diameter, chamfer edges A and C to approximately 0.050" x 45° [1.0 mm x 45°].
7. Remove trimming tool from impeller magnet assembly and clean up any loose material with a knife.

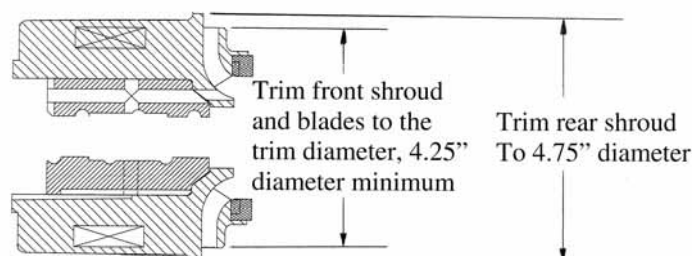
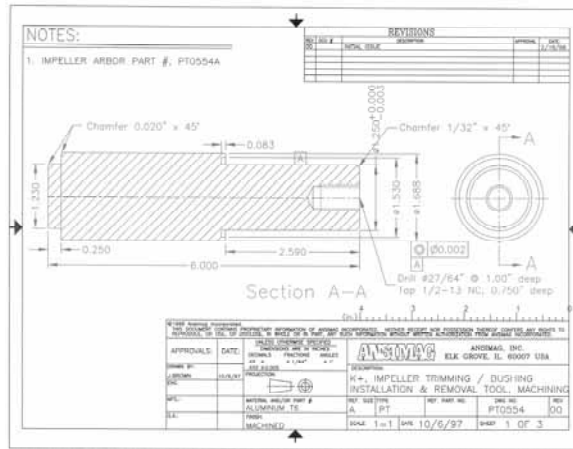

Fig. 11-4

To make your own K+ impeller tools...



GFR / PFA Trimming Tool Fig. 11-6

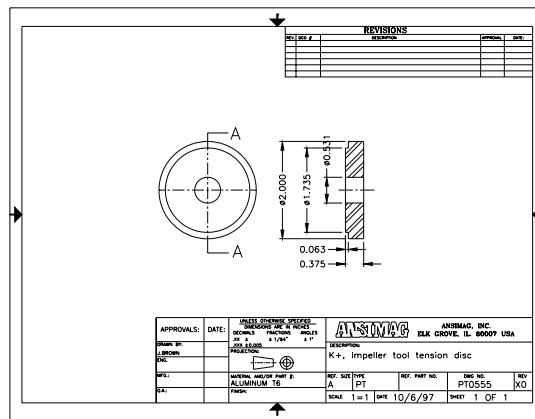
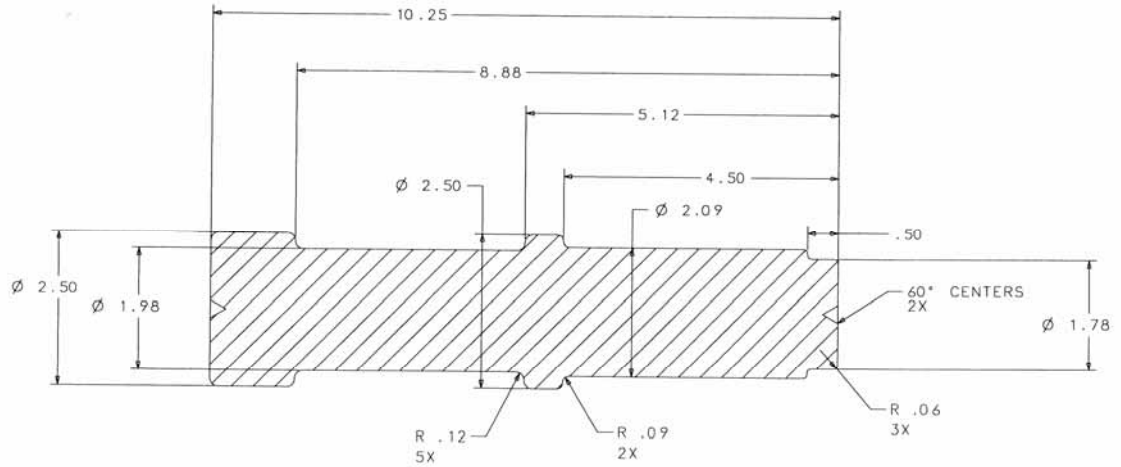
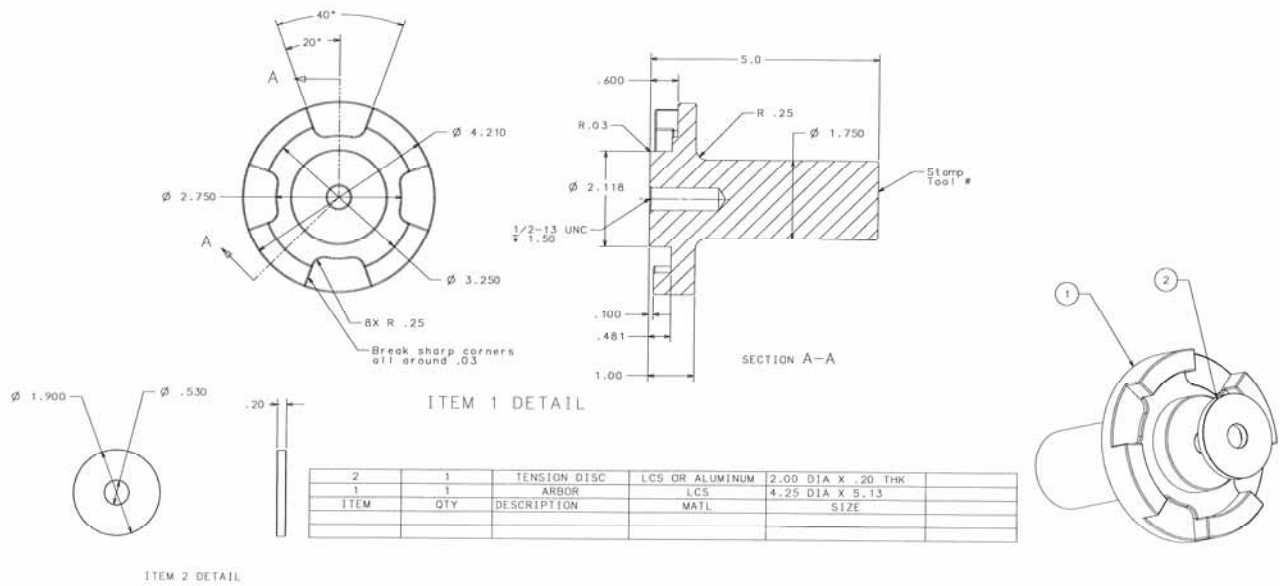

Fig. 11-7



CFR / ETFE Drive Lug Disassembly Tool (PT0820)
Material: UHMW
Fig. 11-8



CFR / ETFE Impeller Trim Arbor (PT0827)
Fig. 11-9

12. BEARING FRAME DISASSEMBLY & MAINTENANCE

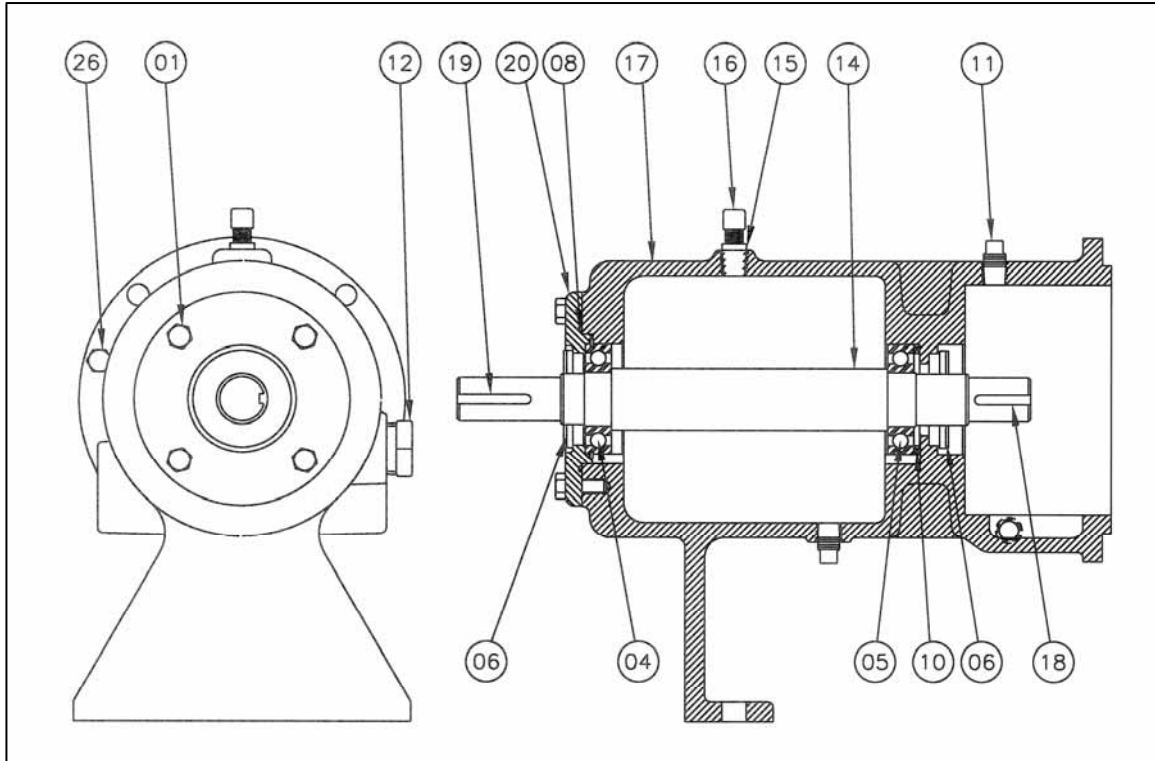

Fig. 12-1: Bearing Frame Assembly

12-a. DISASSEMBLY

Tools Needed:

Adjustable wrench

T handle long 3/16" Allen wrench

1. Remove the coupling guard. Disconnect the flexible coupling between the motor shaft and bearing frame shaft. Drain the oil from the bearing frame using the drain plug on the bottom (8). Unbolt the bearing frame foot from the base plate.

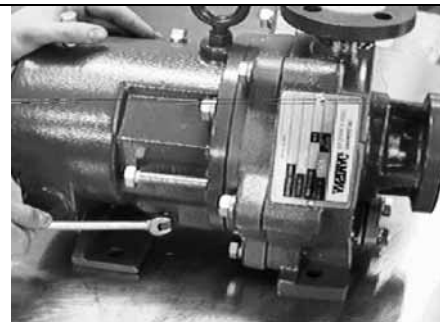

Fig. 12-2: Drain Plug

2. Decouple the bearing frame from the pump by removing the four bolts that connect the bearing frame to the pump rear casing support. Use the jackscrews provided to safely decouple the outer drive from the inner drive. If the bearing frame happens to be an older model without jackscrews, manually pull on the bearing frame to decouple the outer drive from the inner drive.

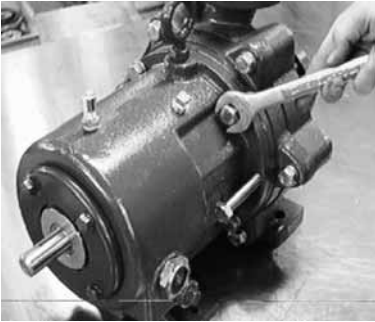

Fig. 12-3: Bolts to Connect Bearing Frame

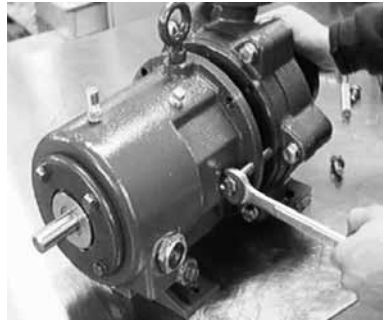

Fig. 12-4: Jackscrews to Decouple Drives

3. Disconnect the outer drive(9) from the shaft by removing the 3/8" NPT plug to expose the two set screws that secure the outer drive to the shaft. Loosen the set screws with the T handle long 3/16" Allen wrench.

Note: When a two-piece outer drive assembly is installed, it is possible to remove only the OMR, leaving the hub mounted to the drive shaft. To remove the OMR, remove the two (2) countersunk, flat mounting screws on the interior bottom surface of the OMR. If needed, 1/4 - 20 UNC jackscrews are available.

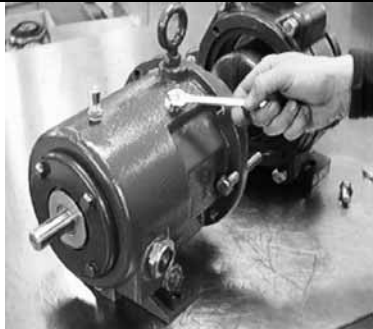

Fig. 12-5: Remove 3/8" Plug to Expose Set Screws

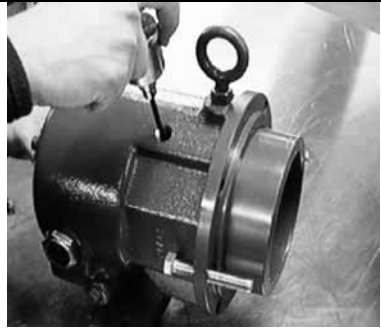

Fig. 12-6: Loosen Set Screws

4. The outer drive or OMR should slide off the shaft by hand. If not there may be oxidation buildup between the outer drive and the shaft. Use a **nonmetallic** mechanical puller and the 1/4-20 UNC holes provided to extract the outer drive. Do not force the outer drive off the shaft since this could damage the bearings or labyrinth seal.

Caution: Use nonmetallic tools to avoid personal injury or damage to the parts.



Fig. 12-7: Slide Outer Drive off Shaft or OMR from Adapter Hub

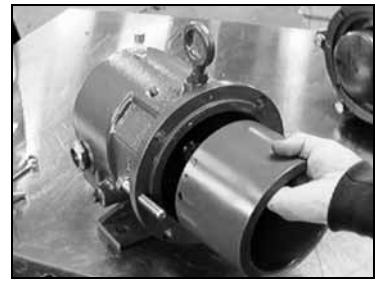





Fig. 12-8: Slide Outer Drive off Shaft or OMR from Adapter Hub

<p>5. Unbolt and remove the bearing cap.</p>		
	<p>Fig. 12-9: Unbolt Bearing Cap</p>	<p>Fig. 12-10: Remove Bearing Cap</p>

<p>6. Extract the shaft by carefully pulling the shaft towards the motor end. It may be necessary to lightly tap the pump side of the shaft with a hammer against a brass rod to unseat the shaft assembly. There is a tight fit between the shaft assembly and the bearing frame.</p>		
	<p>Fig. 12-11: Tap Out Shaft Assembly</p>	<p>Fig. 12-12: Remove Shaft Assembly</p>

12-b. INSPECTION & MAINTENANCE OF BEARING FRAME

The following components should be inspected and replaced as needed:

Bearings: The bearings should be cleaned if they are dirty. If they seem to be noisy or rough when rotated they need to be replaced. Check for pits or grooves in the outer race of the bearings and replace the bearing unit if any are found. The oil should be changed whenever the bearings are replaced.

Shaft Assembly: Check all rotating smooth machined surfaces for wear and scoring, and replace the shaft assembly if necessary.

Labyrinth seals: Replace the labyrinth seals if they are worn or damaged or if the O-rings are worn.

Oil: Ansimag recommends flushing the bearing housing to remove dirt, grit and other impurities that may have entered the bearing housing during shipment or installation. The recommended lubricant is ISO VG 68 synthetic lubricant. Make the first oil change after 400 hours of operation for new bearings if the pump is operating under normal conditions, i.e. experiencing only moderate temperature changes, humidity and dirt. Check the level and condition of the oil through the sight glass on the bearing frame. Check for unusual noise, vibration, and bearing frame oil temperatures.

Oil (Continued):

Amount of oil required: Group I - 17 fl.oz. (.53 qt.)
 Group II - 33 fl.oz. (1.03 qt.)



Schedule for Oil Changes: Oil temps below 160 F = 36 months
 Oil temps between 160 F and 200 F = 24 months
 Oil temps between 200 F and 250 F = 12 months

* Maintenance intervals based on a clean reservoir protected from contamination. Drain if contaminated. Also shorten first drain if added to dirty reservoir.

12-c. ASSEMBLY OF THE BEARING FRAME

[If shaft assembly and labyrinth seals are already assembled skip to Step 5]

<p>1. Start by lightly lubricating the labyrinth seals on the outside O-ring. Install the labyrinth seal with the expulsion port at the 6 o'clock position facing down, since it works by gravity.</p>	 <p>Fig. 12-13: Labyrinth Seal w/ Port at 6 o'clock</p>
--	--

<p>2. Use an arbor press and wide flat arbor (necessary to distribute the load over the entire face) to install the labyrinth seal into the bearing cap. The OD of the seal is stepped - insert the smaller diameter into the bearing cap. Press it in only as far as the first step will allow and avoid angular misalignment. Discard any residual material from the outer O-ring.</p>	 <p>Fig. 12-14: Install Labyrinth Seal in Bearing Cap</p>	 <p>Fig. 12-15: Labyrinth Seal in Bearing Cap</p>
--	--	---

3. Use an arbor press and wide flat arbor (necessary to distribute the load over the entire face) to install the labyrinth seal into the bearing frame housing cavity, facing the pump side. Insert the smaller diameter of the seal into the cavity. Press it in only as far as the first step will allow and avoid angular misalignment. Discard any residual material from the outer O-ring.



Fig. 12-16: Install Labyrinth Seal into Cavity



Fig. 12-17: Labyrinth Seal in Cavity

4. To assemble the shaft assembly, be aware that the bearing with the lock ring is installed on the motor side. Place the bearing with the lock ring facing down, trying to avoid any angular misalignment and insert the shaft with the longer key-way first until the shaft bottoms out in the bearing. Place the other bearing on the other end of the shaft and press the shaft in until the shaft shoulder bottoms out against the bearing inner race.

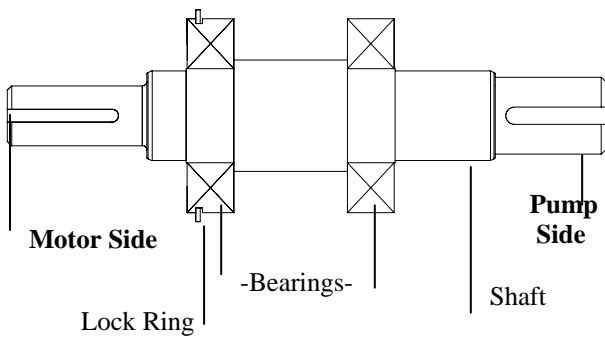

Fig. 12-18: Shaft Assembly

5. To press the shaft assembly into the bearing frame carefully stand the bearing frame upright on the pump side end. Lightly lubricate the first step on both sides of the shaft to allow it to slide through the labyrinth seal bore. Drop in the carbon steel wave washer as shown in the drawing. Insert the shaft assembly (with the shortest key-way first) by aligning the bearing with the bearing seat and lightly tapping the end of the shaft with a brass hammer until the shaft assembly bottoms out in the bearing seat.



Fig. 12-19: Insert Shaft Assembly into Bearing Frame



Fig. 12-20: Tap Shaft Assembly into Place

6. To install the bearing frame cap, lightly apply a small bead of grease in the O-ring groove in the bearing cap. The grease will keep the O-ring from falling out of its seat when the bearing cap is bolted down. Install the bearing cap over the shaft and bolt down with the four supplied 3/8-16 UNC bolts. Rotate the shaft to insure that the shaft spins freely. Make sure that the rotors on both ends of the bearing frame are seated against the stator by pressing them together with hand pressure.

7. Secure the bearing frame on a level plane before filling with oil. Remove the breathing tube and filling until the oil level is in the middle of the bull's eye in the sight glass.
If the bearing frame is filled on an uneven surface or tilted afterward, oil will fill the labyrinth seal. Oil will slowly leak out of the seal port at the 6 o'clock position until the labyrinth seal is fully purged.



Fig. 12-21: Remove Breathing Tube



Fig. 12-22: Fill Bearing Frame with Oil

13. PARTS LIST

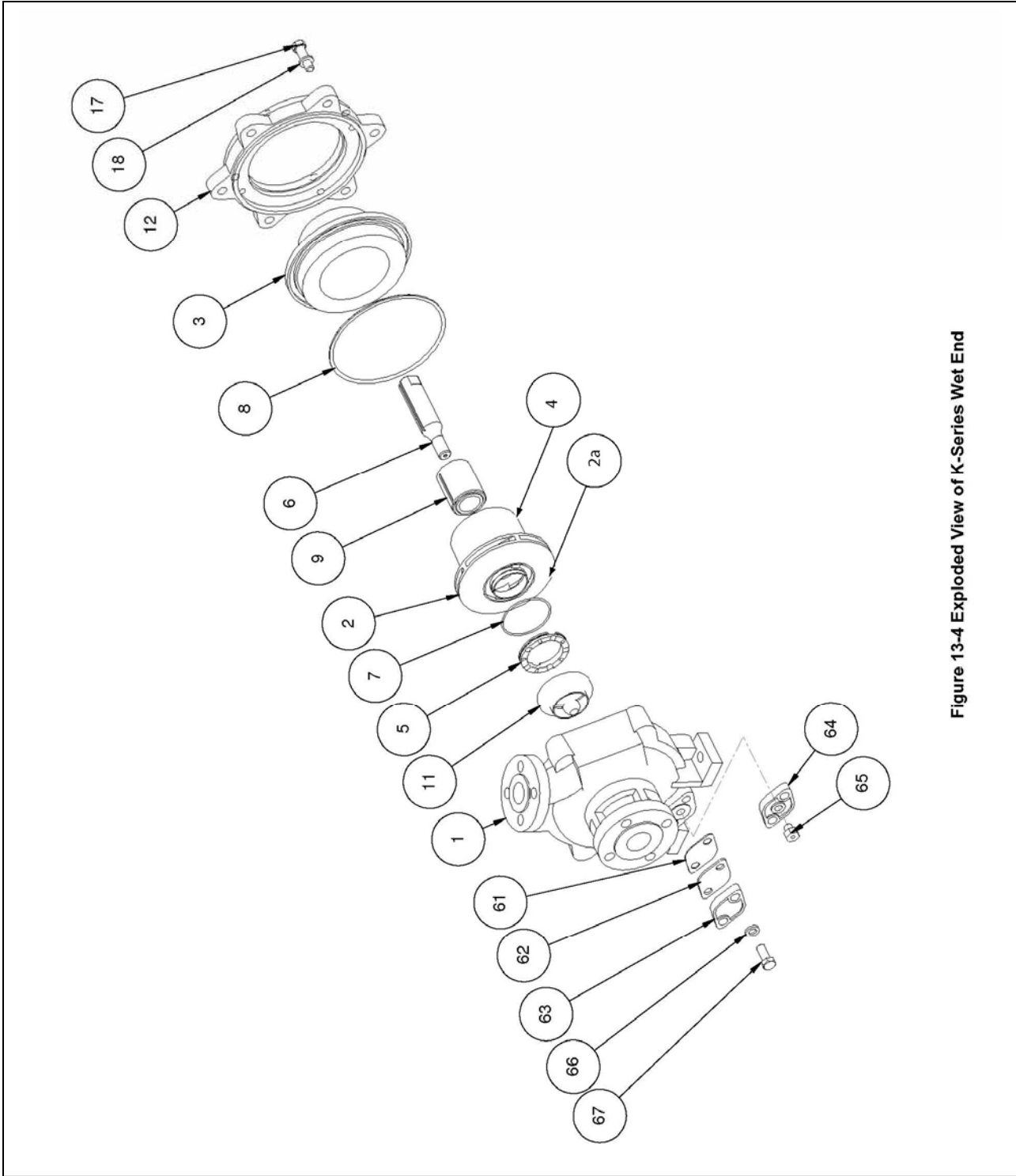
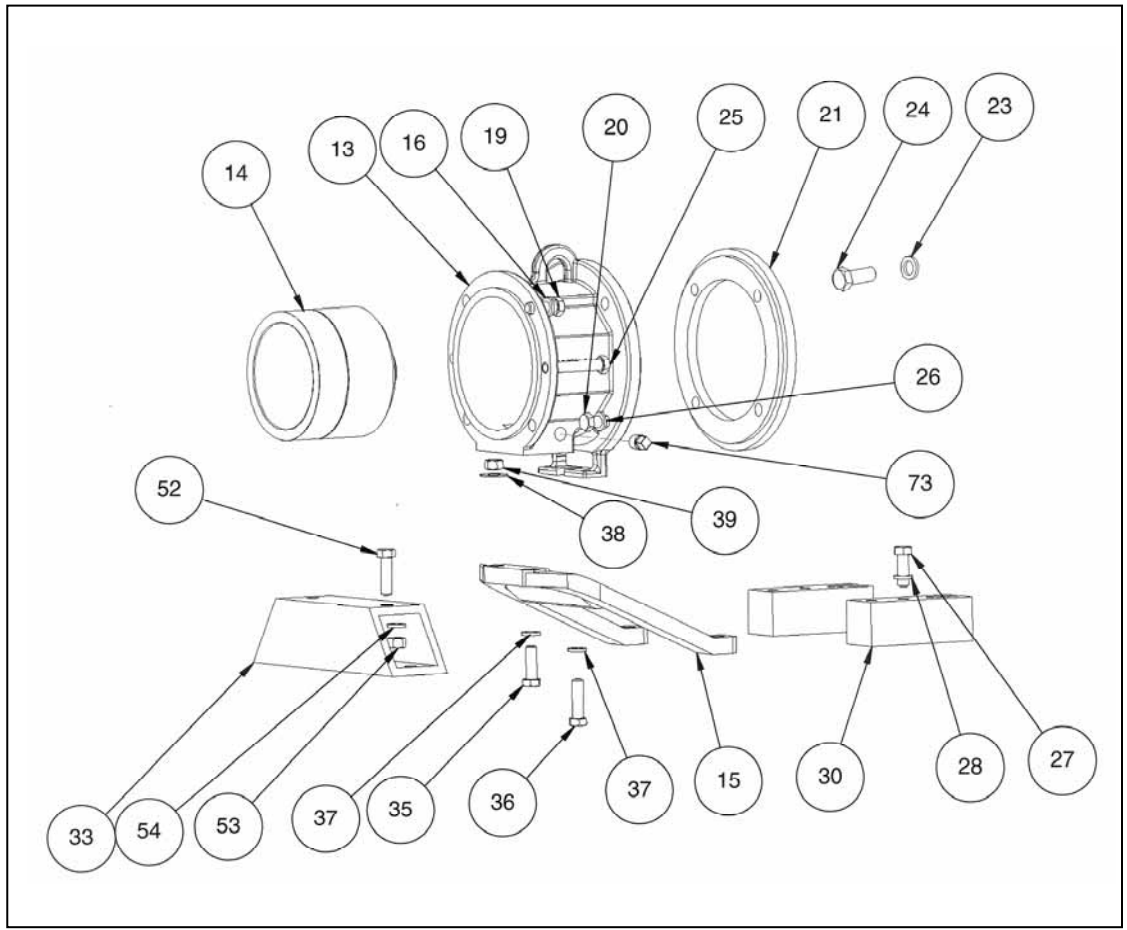
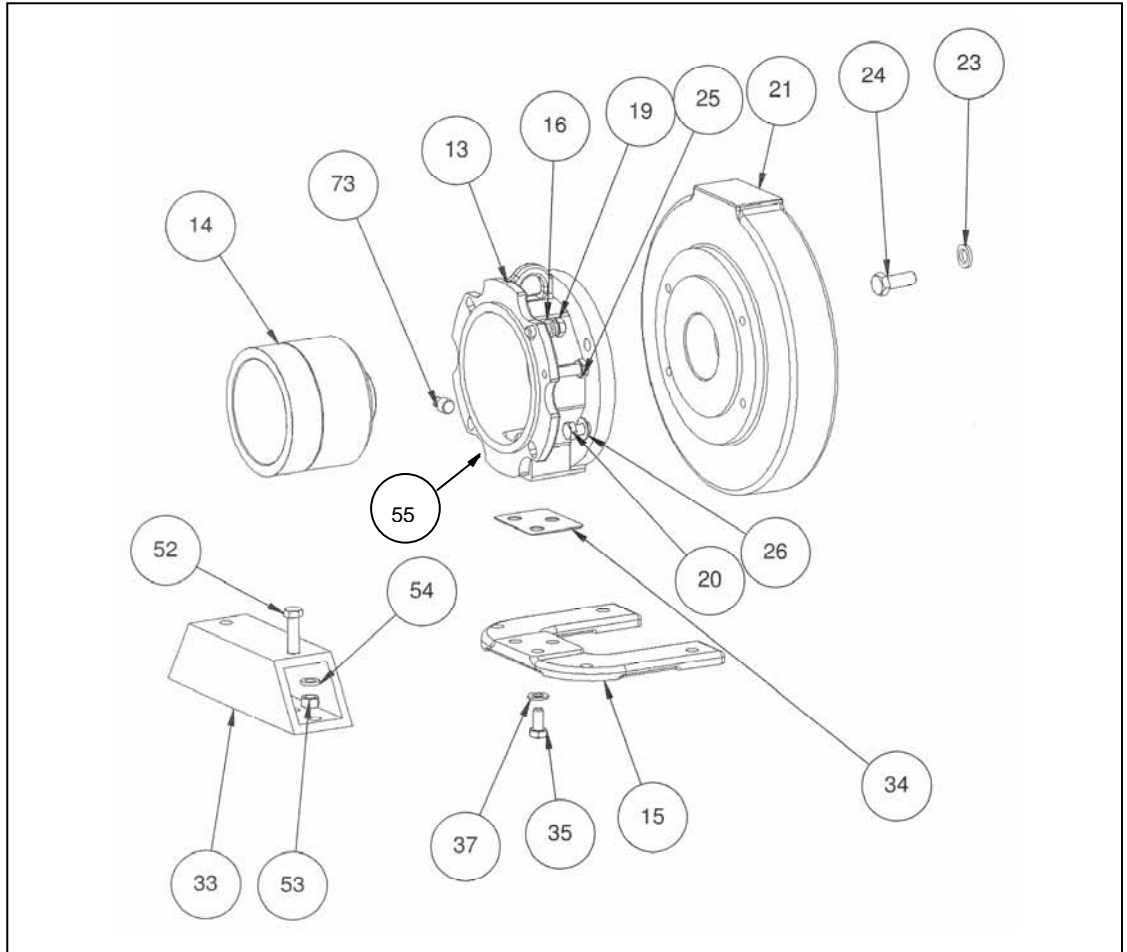

Figure 13-4 Exploded View of K-Series Wet End

**Fig. 13-5:
Exploded
View of
NEMA
Drive
End**



**Fig. 13-6
Exploded
View of IEC
Drive End**



PARTS LIST 1

WET END PARTS ONLY – ANSI PUMPS

Recommended Spare Parts for all levels of service.

	PART NAME	QTY	K+1516	K+3156	K+326s	K+326	K+436	K+1518	K+3158
<input checked="" type="checkbox"/>	1 Casing – 150 LB	1							
	ETFE lined		K0107	P2847	P2846	K0108	K0109	K0110	K0111
	CI PFA Lined		K0107P	N/A	N/A	N/A	N/A	N/A	N/A
	Stainless Steel, 316		K0107B	N/A	N/A	K0108 B	K0109B	K0110B	K0111B
	Hastelloy® B		K0107E	N/A	N/A	K0108 E	K0109E	K0110E	K0111E
	Hastelloy® C		K0107G	N/A	N/A	K0108 G	K0109G	K0110G	K0111G
<i>I</i>	Casing – 300 LB								
	Stainless Steel, 316		K0107C	N/A	N/A	K0108 C	K0109C	K0110C	K0111C
	Hastelloy® B		K0107F	N/A	N/A	K0108F	K0109F	K0110F	K0111F
	Hastelloy® C		K0107H	N/A	N/A	K0108 H	K0109H	K0110H	K0111H
<input checked="" type="checkbox"/>	2 Fully Encapsulated Drive – CFR/ETFE	1							
	A-drive, 10hp/3600, 5hp/1800		P2842AE	P2843AE			P2844AE	K0211E	K0214E
	B-drive, 15hp/3600, 7.5hp/1800		P2842BE	P2843BE			P2844BE	K0212E	K0215E
	C-drive, 30hp/3600, 15hp/1800		P2842CE	P2843CE			P2844CE	K0213E	K0216E
	Impeller Assembly – GFR/PFA								
	A-drive 10hp/3600, 5hp/1800		P2842D	P2843D			P2844D	K0211P	K0214P
	B-drive 15hp/3600, 7.5hp/1800		P2842E	P2843E			P2844E	K0212P	K0215P
	C-drive 30hp/3600, 15hp/1800		P2842F	P2843F			P2844F	K0213P	K0216P
	2a Impeller Only (CFR /ETFE)	1	P4110	P4161			P4162	P4163	P4106
<input checked="" type="checkbox"/>	3 Containment Shell	1							
	CFR/ETFE w/CFR/Teflon®			P2912A				P2913A	
	GFR/PFA w/CFR/Teflon®			P2912B				P2913B	
	4 Inner Drive Only – CFR/ETFE A-drive 10hp/3600, 5hp/1800 B-drive 15hp/3600, 7.5hp/1800 C-drive 30hp/3600, 15hp/1800	1				P4172A P4172B P4172C			
<input checked="" type="checkbox"/>	5 Mouth Ring Assembly	1							
	CFR-Teflon®		K0501	K0503			K0505	K0501	K0510
	SiC		K0506	K0507			K0508	K0506	K0509
<input checked="" type="checkbox"/>	6 Pump Shaft –SiC	1	K0607						
**	7 O-Ring, Mouth Ring	1	K0705	K0706			K0707	K0705	K0707

PART LIST 1, continued
WET END PARTS ONLY - ANSI PUMPS

	PART NAME	QTY	K+1516	K+3156	K+326s	K+326	K+436	K+1518	K+3158
✓	8 O-Ring, Casing	1							
	Viton®				K0801			K0810	
	EPDM				K0802			K0811	
	Teflon® coated Viton®				K0803			K0812	
	Gore-Tex® wrapped Teflon®/Viton®				P2343			P2344	
	Silicone				K0804			Consult Factory	
✓	9 Main Bushing	1							
	CFR-ETFE, SiC (Ribbed, Keyless) CFR-ETFE, SiC					P4175 K0907			
	GFR-PFA, SiC					K0907P			
	Carbon (Ribbed, Keyless) Carbon					P4175A K0908			
✓	11 Shaft Support/Thrust Ring	1							
	CFR-ETFE / SiC		K1102		K1104		P2915A	K1102	K1107
	GFR-PFA / SiC		K1102P		K1104P		P2915B	K1102P	K1107P
	12 Rear Support	1							
	Ductile Iron					K1201		P2363A	
	Stainless Steel					K1206		P2363B	
	17 Lock Washer 1/2" (Rear Support – Casing)					HL1/2 6 REQ		HL1/2 8 REQ	
	18 Hex bolts 1/2"-13 (Rear Support – Casing)					HH1/2X1.50 6 REQ		HH1/2X1.75 8 REQ	
*	61 Teflon Gasket (Drain)	1				K4903			
*	62 Neoprene Gasket (Drain)	1				K4904			
*	63 Drain Cover	1				K4902			
	64 Threaded Drain Cover (1/4" NPT)	1				P2034			
	65 Drain Plug	1				P2035			
*	66 Lock Washers 1/2" (Drain Cover- Casing)	2				HL1/2			
*	67 Hexbolts 1/2"- 13 (Drain Cover- Casing)	2				HH1/2X1.25			

Notes: 1. ANSI 300# flanges are available only on unlined 316 stainless steel or Hastelloy® pump cases.

* These items are included when ordering casings

** These items are included when ordering mouth rings

PART LIST 2

DRIVE END PARTS ONLY - ANSI PUMPS WITH NEMA MOTORS

	PART NAME	Qty	K+1516	K+3156	K+326s	K+326	K+436	K+1518	K+3158	
13	Close-Coupled Bracket, NEMA	1	P2562							
14	Outer Drive	1								
	A-drive, 56C frame		K1400							
	A-drive, 143/145TC		K1402							
	A-drive, 182/184TC		K1401							
	A-drive, 213/215TC		K1408							
	A-drive, long coupled		K1411							
	B-drive, 56C		P2236D							
	B-drive, 143/145TC		P2236E							
	B-drive, 182/184TC		K1404							
	B-drive, 213/215TC		K1403							
	B-drive, 254/256TC & 284/286TSC		K1409							
	B-drive, long coupled		K1412							
	C-drive, 182/184TC		P2236Z							
	C-drive, 213/215TC		P2236F							
	C-drive, 254/256TC & 284/286TSC		P2236G							
	C-drive, 324/326TSC		P2236N							
	C-drive, long coupled		P2236L							
14a	Outer Magnet Ring	1								
	A Drive		P4091A							
	B Drive		P4091B							
	C Drive		P4091C							
14b	Adapter Hub	1								
	56C		P4069M							
	143/145TC		P4069P							
	182/184TC		P4069W							
	213/215TC		P4069U							
	254/256TC & 284/286TSC		P4069J							
	324/326TC Contact ANSIMAG Representative		P4069F							
	Long Coupled		P4069F							
14c	Flat Head Countersunk Cap Screws	2	02-414DJ							
15	Bracket Foot, close coupled	1	N/A			P2536		N/A		P2536
16	Lock Washers 1/2", Rear Support – Bracket	4	HL1/2							
19	Hex Bolts 1/2"-13, Rear Support – Bracket	4	HH1/2X1.5							

PART LIST 2

DRIVE END PARTS ONLY - ANSI PUMPS WITH NEMA MOTORS

	PART NAME	Qty	K+1516	K+3156	K+326s	K+326	K+436	K+1518	K+3158
20	Hex Bolts 1/2"-13, Bracket-Motor Mounting Plate 56C & 143/145TC 182/184TC 213/215TC 254/256TC 284/286TSC	4				HH1/2X1.25 HH1/2X1.50 HH1/2X2.00 HH1/2X2.50 HH1/2X1.25			
21	Motor Mounting Plate 56C & 143/145TC 182/184TC 213/215TC 254/256TC 284/286TSC long coupled	1 N/A 1 2 1 N/A				K3001 N/A K3002 K3002 K3004 N/A			
24	Bolt, Motor Mounting Plate/Motor 56C & 143/145TC 182/184TC 213/215TC 254/256TC 284/286TSC	4 4				HF 3/8X.75 N/A N/A N/A HSL1/2X1.00			
25	Jack Screws	2				HH1/2X3.00, full thread FT			
26	Lock Washers 1/2", Bracket-Motor Mounting Plate	4				HL1/2			
27	Hexbolts (Motor- Motor Riser) 56C & 143/145TC 182/184TC 213/215TC 254/256TC 284/286TSC	N/A N/A 4 4 4	N/A N/A N/A N/A HH1/2X1.75	N/A N/A N/A N/A	N/A N/A HH3/8X1.25 HH1/2X2.0 HH1/2X1.75	N/A N/A N/A N/A HH1/2X1.75	N/A N/A HH3/8X1.25 HH1/2X2.0 HH1/2X1.75		
28	Lock Washers S.S. (Motor – Motor Riser) 56C & 143/145TC 182/184TC 213/215TC 254/256TC 284/286TSC	N/A N/A 4 4 4	N/A N/A N/A N/A HL1/2	N/A N/A HL3/8 HL1/2 HL1/2	N/A N/A HL3/8 HL1/2 HL1/2	N/A N/A N/A N/A HL1/2	N/A N/A HL/38 HL1/2 HL1/2		
30	Motor Risers, Close-Coupled 56C & 143/145TC (pair) 182/184TC (pair) 213/215TC (pair) 254/256TC (pair) 284/286TSC (pair)	1 1 1 1 1	N/A N/A N/A N/A P2816	N/A N/A P2852 P2815 P2816	N/A N/A P2852 P2815 P2816	N/A N/A N/A N/A P2816	N/A N/A P2852 P2815 P2816		
	Motor Risers, Long-Coupled 56C & 143/145TC (pair) 182/184TC (pair) 213/215TC (pair) 254/256TC (pair) 284/286TSC (pair)	1 1 1 1 1	K2103 K2201 N/A N/A K2305	K2103/K2303 K2201/K2303 K2303 K2302 P2543	K2103 K2201 N/A N/A P2305	K2103/K2303 K2201/K2303 K2303 K2302 P2543			
33	Pump Casing Riser 56C & 143/145TC 182/184TC 213/215TC 254/256TC 284/286TSC	N/A N/A N/A N/A N/A	N/A N/A N/A K2307 K2306	N/A N/A N/A N/A N/A	N/A N/A N/A K2307 K2306	N/A N/A N/A K2307 K2306	N/A N/A N/A N/A N/A		
35	Hexbolts 1/2" – 13 (Bracket – Bracket Riser, front)	2	N/A		HH1/2X1.50	N/A	HH1/2X1.50		

PART LIST 2

DRIVE END PARTS ONLY - ANSI PUMPS WITH NEMA MOTORS

	PART NAME	Qty	K+1516	K+3156	K+326s	K+326	K+436	K+1518	K+3158
36	Hexbolt 1/2" – 13 (Bracket – Bracket Riser, rear)	1	N/A			HH1/2X1.75	N/A	HH1/2X1.75	
37	Lock Washers 1/2" ³ (Bracket – Bracket Riser)	3	N/A			HL1/2	N/A	HL1/2	
38	Flat Washer 1/2" (Bracket – Bracket Riser, rear)	1	N/A			HW1/2	N/A	HW1/2	
39	Hexnut 1/2 (Bracket- Bracket Foot, rear)	1	N/A			HN1/2	N/A	HN1/2	
52	Hexbolt, Casing- Casing Riser	2							
	56C & 143/145TC		N/A			N/A	N/A	N/A	
	182/184TC		N/A			N/A	N/A	N/A	
	213/215TC		N/A			N/A	N/A	N/A	
	254/256TC	2	HH1/2X1.50			N/A	HH1/2X1.50	N/A	
	284/286TSC	2	HH1/2X1.50			N/A	HH1/2X1.50	N/A	
53	Hexnut, Casing- Casing Riser								
	56C & 143/145TC		N/A			N/A	N/A	N/A	
	182/184TC		N/A			N/A	N/A	N/A	
	213/215TC		N/A			N/A	N/A	N/A	
	254/256TC		N/A			N/A	N/A	N/A	
	284/286TSC		HN1/2			N/A	HN1/2	N/A	
54	Lock Washer, Casing- Casing Riser								
	56C & 143/145TC		N/A			N/A	N/A	N/A	
	182/184TC		N/A			N/A	N/A	N/A	
	213/215TC		N/A			N/A	N/A	N/A	
	254/256TC	2	HL1/2			N/A	HL1/2	N/A	
	284/286TSC	2	HL1/2			N/A	HL1/2	N/A	
73	Bracket Plug, Drain	1	K3902			K3902	K3902	K3902	
74	Bracket Plug, Setscrew	1	K3902			K3902	K3902	K3902	

Notes:

1. With 28 frame mounting, all models require Item 15, P2536 bracket foot and hardware items 35, 36 and 38.

PARTS LIST 3
DRIVE END PARTS ONLY - ANSI PUMPS WITH IEC MOTORS

	PART NAME	Qty	K+1516	K+3156	K+326s	K+326	K+436	K+1518	K+3158
14	Outer Drive	1							
	A-drive, IEC B5 80 frame			RK1400		RK1400			
	A-drive, IEC B5 90 frame					RK1401			
	A-drive, IEC B5 100/112 frame					RK1402			
	A-drive, IEC B5 132 frame					RK1403			
	B-drive, IEC 80 frame					P2236H			
	B-drive, IEC B5 90 frame					RK1404			
	B-drive, IEC B5 100/112 frame					RK1405			
	B-drive, IEC B5 132 frame					RK1406			
	B-drive, IEC B5 160 frame					RK1407			
	C-drive, IEC B5 132 frame					P2236V			
	C-drive, IEC B5 160 frame					P2236U			
14a	Outer Magnet Ring	1							
	A – Drive					P4091A			
	B – Drive					P4091B			
	C – Drive					P4091C			
14b	Adapter Hub	1							
	IEC B5 80					P4069N			
	IEC B5 90					P4069R			
	IEC B5 100/112					P4069S			
	IEC B5 132					P4069V			
	IEC B5 160					P4069K			
14c	Flat Head Counter sunk	2				02-414DJ			
15	Bracket Foot - Close-Coupled	1							
	80, 90, 100/112 frame			P1942		RK4507	P1942	RK4507	
	132 frame			RK4507		RK4507	RK4507	RK4507	
	160 frame			RK4507		RK4507	RK4507	RK4507	
16	Lock Washers, ½” (Rear Casing Support – Bracket)	4				HL1/2			
19	Hex Bolts ½” (Rear Support –Bracket)	4				HH1/2X1.5			
20	Hex Bolts 304SS (Bracket – Motor Mounting Plate)	4				HHM12X35			
21	Motor Mounting Plate	1							
	80, 90 Frame					RK3002			
	100/112 Frame					RK3003			
	132 Frame					RK3004			
	160 Frame					RK3005			
23	Lock Washers (Motor Mounting Plate/Motor)	4							
	80, 90 frame					HLM10			
	100/112 frame					HLM12			
	132 frame					HLM12			
	160 frame					HLM16			

PARTS LIST 3 (Cont'd)

DRIVE END PARTS ONLY – ANSI PUMPS WITH IEC MOTORS

	PART NAME	Qty	K+1516	K+3156	K+326s	K+326	K+436	K+1518	K+3158
24	Hex Bolts (Motor Mounting Plate/Motor)	4							
	80, 90 frame					HHM10X25			
	100,112 frame					HHM12X25			
	132 frame					HHM12X30			
	160 frame					HHM16X40			
25	Jack Screws M12	2				HHM12X40FT			
26	Lock Washers M12 (Bracket – Motor Mounting Plate)	4				HLM12			
33	Pump Casing Riser	1							
	80, 90, 100, 112 frame					N/A			
	132 frame			K2306		N/A	K2306		N/A
	160 frame			K2306		N/A	K2306		N/A
34	Foot Riser	1							
	80, 90, 100/112 frame			RK5000		N/A	RK5000		N/A
	132, 160 frame			N/A		N/A	N/A		N/A
35	Hex Bolts M12 (Bracket-Bracket Foot)	3							
	89, 90, 100/112 frame			HHM12X25		HHM12X40	HHM12X25		HHM12X40
	132, 160 frame			HHM12X40		HHM12X40	HHM12X40		HHM12X40
37	Lock Washers M12 (Bracket-Bracket Foot)	3				HLM12			
52	Hex Bolts 1/2" (Casing – Casing Riser)	2							
	80, 90, 100/112 frame			N/A		N/A	N/A		N/A
	132 frame			HH1/xX1.5		N/A	HH1/2X1.5		N/A
	160 frame			HH1/2X1.5		N/A	HH1/2X1.5		N/A
53	Hex Bolts 1/2" (Casing – Casing Riser)								
	132 frame			HN1/2		N/A	HN1/2		N/A
	160 frame					N/A	HH1/2X1.5		N/A
54	Lock Washers M12 (Casing – Casing Riser)	2				HL1/2			
73	Bracket Plug, Drain	1					K3902		

PART LIST 4

WET END PARTS ONLY – ISO PUMPS

Recommended Spare Parts for all levels of service

		PART NAME - ISO Pumps	QTY	K+i32160	K+i50160	K+i65160	K+i32200	K+i40200
		- JIS Pumps	QTY	K+j40160	K+j50160	K+j65160	K+j40200	K+j50200
<input checked="" type="checkbox"/>	1	Casing – ISO 2084, 16 Bar, ETFE Lined Ductile Iron	1	RK0107	RK0108	RK0109	RK0110	RK0111
		Casing – JIS 10KG/CM², ETFE Lined Ductile Iron	1	JK0107	JK0108	JK0109	JK0110	JK0111
<input checked="" type="checkbox"/>	2	Fully Encapsulated Drive – CFR/ETFE	1					
		A-drive, 7.5 KW/3500, 3.75KW/1750, 5.5KW/2900, 3.0KW/1450		P2842AE	P2843AE	P2844AE	K0211E	K0214E
		B-drive, 11KW/3500, 5.5KW/1750, 7.5KW/2900, 4.0KW/1450		P2842BE	P2843BE	P2844BE	K0212E	K0215E
		C-drive, 22KW/3500, 11KW/1750, 18.5KW/2900, 9KW/1450 ¹		P2842CE	P2843CE	P2844CE	K0213E	K0216E
		Impeller Assembly - GFR/PFA	1					
		A-drive, 7.5 KW/3500, 3.75KW/1750, 5.5KW/2900, 3.0KW/1450		P2842D	P2843D	P2844D	K0211P	K0214P
		B-drive, 11KW/3500, 5.5KW/1750, 7.5KW/2900, 4.0KW/1450		P2842E	P2843E	P2844E	K0212P	K0215P
		C-drive, 22KW/3500, 11KW/1750, 18.5KW/2900, 9KW/1450 ¹		P2842F	P2843F	P2844F	K0213P	K0216P
	2a	Impeller Only – CFR /ETFE	1	P4110	P4161	P4162	P4163	P4106
<input checked="" type="checkbox"/>	3	Containment Shell	1					
		CFR/ETFE w/CFR/Teflon			P2912A		P2913A	
		GFR/PFA w/CFR/Teflon			P2912B		P2913B	
	4	Inner Drive Only – CFR/ETFE A-drive, 7.5 KW/3500, 3.75KW/1750, 5.5KW/2900, 3.0KW/1450 B-drive, 11KW/3500, 5.5KW/1750, 7.5KW/2900, 4.0KW/1450 C-drive, 22KW/3500, 11KW/1750, 18.5KW/2900, 9KW/1450 ¹	1		P4172A P4172B P4172C		P4172A P4172B P4172C	
<input checked="" type="checkbox"/>	5	Mouth Ring	1					
		CFR-Teflon		K0501	K0503	K0505	K0501	K0510
		SiC		K0506	K0507	K0508	K0506	K0509
<input checked="" type="checkbox"/>	6	Pump Shaft – SiC	1			K0607		
**	7	O-Ring (Mouth Ring)	1	K0705	K0706	K0707	K0705	K0707
<input checked="" type="checkbox"/>	8	O-Ring (Casing)	1					
		Viton®			K0801		K0810	
		EPDM			K0802		K0811	
		Teflon® Coated Viton®			K0803		K0812	
		Gore-Tex® wrapped Teflon® Viton®			P2343		P2344	
		Silicone			K0804		Consult Factory	

PART LIST 4 - continued

WET END PARTS ONLY – ISO PUMPS

Recommended Spare Parts for all levels of service

<input checked="" type="checkbox"/>	9	Main Bushing	1					
		CFR-ETFE, SiC (Keyless Ribbed) CFR / ETFE Sic (Keyed)		P4175 K0907				
		CFR-PFA, SiC		K0907P				
		Carbon (Keyless Ribbed) Carbon		P4175A K0908				
<input checked="" type="checkbox"/>	11	Shaft Support/Thrust Ring	1					
		CFR-ETFE / SiC		K1102	K1104	P2915A	K1102	K1107
		GFR-PFA / SiC		K1102P	K1104P	P2915B	K1102P	K1107P
PART NAME - ISO Pumps								
		PART NAME - ISO Pumps	QTY	K+i32160	K+i50160	K+i65160	K+i32200	K+i40200
		- JIS Pumps	QTY	K+j40160	K+j50160	K+j65160	K+j40200	K+j50200
	12	Rear Support	1					
		Ductile Iron		K1201			P2363A	
		Stainless Steel		K1206			P2363B	
	17	Lock Washer 12MM – Rear Support/Casing		HLM12 6 REQ			HLM12 8 REQ	
	18	Hex Bolts 12MM – Rear Support/Casing		HHM12X40 6 REQ			HHM12X45 8 REQ	
*	61	Teflon Gasket, Drain	1	K4903				
*	62	Neoprene Gasket, Drain	1	K4904				
*	63	Drain Cover	1	K4902				
	64	Threaded Drain Cover (1/4" NPT)	1	P2034				
	65	Drain Plug	1	P2035				
*	66	Lock Washers M12, Drain Cover/Casing	2	HLM12				
*	67	Hexbolts 12MM, Drain Cover/Casing	2	HHM12X30				

* These items are included when ordering casings.

** These items are included when ordering mouth rings.

PARTS LIST 5

DRIVE END PARTS ONLY – ISO PUMPS WITH IEC MOTORS

	PART NAME - ISO Pumps	QTY	K+i32160	K+i50160	K+i65160	K+i32200	K+i40200
	- JIS Pumps	QTY	K+j40160	K+j50160	K+j65160	K+j40200	K+j50200
13	Bracket, Close-coupled, IEC	1			RK1302		
14	Outer Drive	1					
	A-drive, IEC B5 80 frame				RK1400		
	A-drive, IEC B5 90 frame				RK1401		
	A-drive, IEC B5 100/112 frame				RK1402		
	A-drive, IEC B5 132 frame				RK1403		
	B-drive, IEC B5 90 frame				RK1404		
	B-drive, IEC 80 frame				P2236H		
	B-drive, IEC B5 100/112 frame				RK1405		
	B-drive, IEC B5 132 frame				RK1406		
	B-drive, IEC B5 160 frame				RK1407		
	C-drive, IEC B5 132 frame				P2236V		
	C-drive, IEC B5 160 frame				P2236U		
14a	Outer Magnet Ring	1					
	A – Drive				P4091A		
	B – Drive				P4091B		
	C – Drive				P4091C		
14b	Adapter Hub	1					
	IEC B5 80				P4069N		
	IEC B5 90				P4069R		
	IEC B5 100/112				P4069S		
	IEC B5 132				P4069V		
	IEC B5 160				P4069K		
14c	Flat Head Counter sunk	2			02-414DJ		
15	Bracket Foot – Close Coupled	1					
	80, 90, 100/112 frame		P1942		RK4506	RK4506	RK4506
	132 frame		RK4507		RK4507	RK4507	RK4507
	160 frame		RK4507		RK4507	RK4507	RK4507
16	Lock Washers 12MM, Rear Support/Bracket	4	HLM12				
19	Hex Bolts 1/2” Rear Support/Bracket	4	HHM12X30				
20	Hex Bolts 304SS, Bracket Motor Mounting Plate		HHM12X35				
21	Motor Mounting Plate	1					
	80, 90 frame				RK3002		
	100/112 frame				RK3003		
	132 frame				RK3004		
	160 frame				RK3005		

PARTS LIST 5 – continued

DRIVE END PARTS ONLY – ISO PUMPS WITH IEC MOTORS

	PART NAME - ISO Pumps	QTY	K+i32160	K+i50160	K+i65160	K+i32200	K+i40200	
	- JIS Pumps	QTY	K+j40160	K+j50160	K+j65160	K+j40200	K+j50200	
23	Lock Washers Motor Mounting Plate/Motor	4						
	80, 90 frame		HLM10					
	100/112 frame		HLM12					
	132 frame		HLM12					
	160 frame		HLM16					
24	Hex Bolts Motor Mounting Plate/Motor	4						
	80, 90 frame		HHM10X25					
	100/112 frame		HHM12X25					
	132 frame		HHM12X30					
	160 frame		HHM16X40					
25	Jack Screws M12	2	HHM12X40FT					
26	Lock Washers M12, Bracket Motor Mounting Plate	4	HLM12					
33	Pump Casing Riser	1						
	80, 90, 100/112 frame		N/A					
	132 frame		RK5001		RK5003	RK5003	RK5003	
	160 frame		RK5001		RK5003	RK5003	RK5003	
34	Foot Riser							
	80, 90, 100/112 frame		N/A					
	132, 160 frame		N/A					
35	Hex Bolts M12 Bracket/Bracket Foot	3						
	80, 90, 100/112 frame		HHM12X25	HHM12X40	HHM12X25	HHM12X40	HHM12X40	
	132, 160 frame		HHM12X40	HHM12X40	HHM12X40	HHM12X40	HHM12X40	
37	Lock Washers M12 Bracket/Bracket Foot	3	HLM12					
51	Name Plate, ATEX/CE	1	P4071					
52	Hex Bolts 1/2" Casing – Casing Riser	2						
	80, 90, 100/112 frame		N/A					
	132 frame		HHM12X35	HHM12X40				
	160 frame		HHM12X40					
54	Lock Washers M12 – Casing – Casing Riser)	2	HLM12					
55	Earthing Kit, Grounding Lug	1	P4107					
73	Bracket Plug, 3/8 NPT	1	K3902					

PART LIST 6
BEARING FRAME ONLY

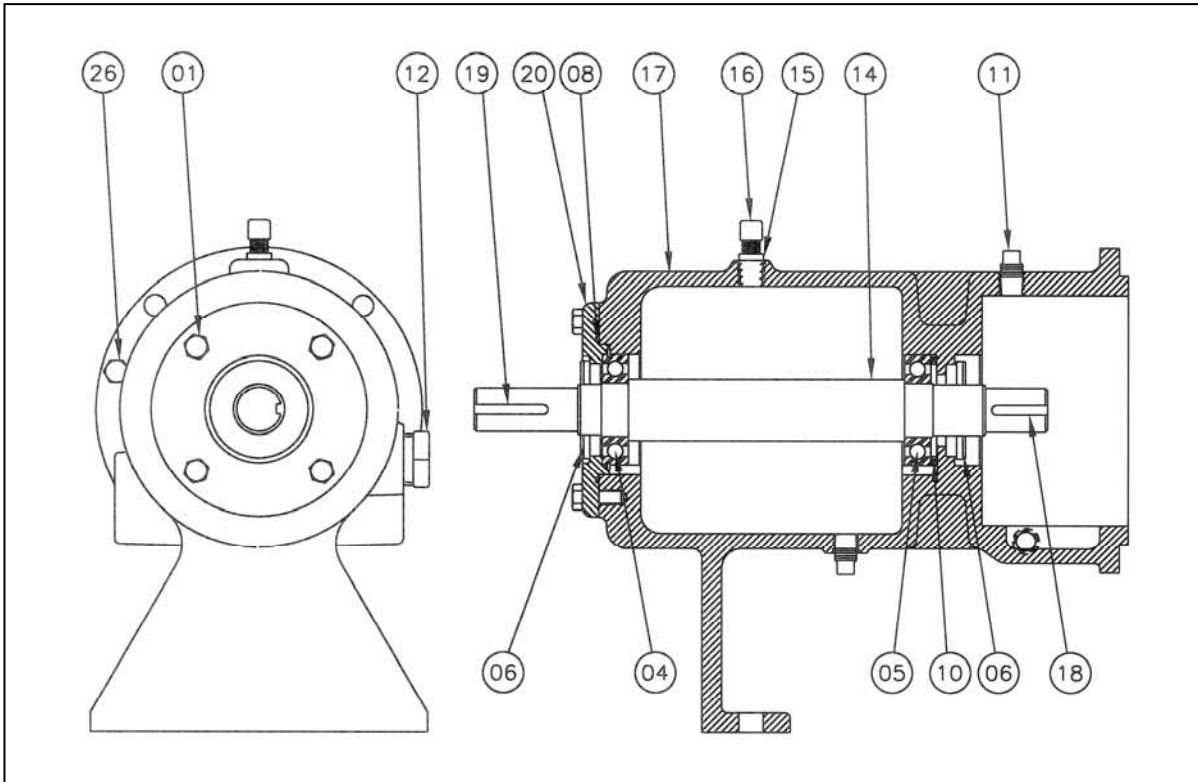

Item #	Part Name	Qty	Group 1	Group 2
			K1516, K326s, K3156, K1518 P2349	K3158, K326, K436 P2350
	Bearing Frame Assembly			
01	Hex Bolt, 3/8-16X7/8	4	HH3/8X0.88	
04	SKF Ball Bearing #6207NRJ	1	K3502	
05	SKF Ball Bearing #6207	1	K3501	
06	Inpro Bearing Isolator 1518-A-09944-0	2	P2434	
08	O-Ring #153	1	K3603	
10	Wave Spring Washer	1	K3702	
11	3/8" NPT Plug	3	K3902	
12	1" NPT Sight Window	1	K4002	
14	Bearing Frame Shaft	1	P2565	P2010
15	1/4" X 1/8" Reducing Bushing	1	K3802	
16	1/8" Breathing Tube	1	K3801	
17	Bearing Frame Housing	1	P1846	P2015
18	Key, 1/4 X 1/4 X 1-1/4	1	P1632E	
19	Key, 3/16 X 3/16 X 1-1/2	1	P1632A	
20	Bearing Frame Cap	1	P2564	
21	Bearing Frame Oil	1	P2501	
26	Hex Bolt, 1/2-13 X 3.00, Fully Threaded	2	HH1/2X3.00FT	
27	Eyebolt	1	N/A	K4701

14. APPROXIMATE SHIPPING WEIGHTS of PUMP & MOTOR MOUNTING

14-a. ANSI Pumps with NEMA Motor Mounting [lbs(kg)]

	K1516	K326, K326s, K3156	K436	K1518	K3158
NEMA T/TC frame size (Drive)	close coupled	close coupled	close coupled	close coupled	close coupled
143 - 145 (A)	90 (41)	118 (54)	128 (58)	93 (42)	119 (54)
182 - 184 (A)	87 (39)	115 (52)	124 (56)	90 (41)	116 (53)
182 - 184 (B)	86 (39)	115 (52)	124 (56)	89 (40)	116 (53)
213 - 215 (A)	90 (41)	121 (55)	131 (59)	93 (42)	123 (56)
213 - 215 (B)	90 (41)	122 (55)	132 (60)	94 (43)	123 (56)
213 - 215 (C)	91 (41)	123 (56)	132 (60)	94 (43)	123 (56)
254 - 256 (B)	97 (44)	133 (60)	143 (65)	100 (45)	134 (61)
254 - 256 (C)	97 (44)	134 (61)	144 (65)	101 (46)	135 (61)
284 TSC (C)	130 (59)	140 (64)	150 (68)	134 (61)	141 (64)
Long coupled	117 (53)	141 (64)	152 (69)	134 (61)	154 (70)

14-b. ANSI Pumps with IEC Motor Mounting [lb(kg)]

	K1516	K326	K436	K1518	K3158
IEC frame size	close coupled	close coupled	close coupled	close coupled	close coupled
80	122(55)	156(71)	167(76)	139(63)	168(76)
90	121(55)	155(70)	166(75)	138(63)	167(76)
100/112	120(54)	153(69)	164(74)	136(62)	166(75)
132	150(68)	163(74)	174(79)	167(76)	175(79)
160	180(82)	193(88)	204(93)	196(89)	206(94)

14-c. ISO Pumps with IEC Motor Mounting [lb(kg)]

	Ki32160	Ki50160	Ki65160	Ki32200	Ki40200
IEC frame size	close coupled	close coupled	close coupled	close coupled	close coupled
80	134(61)	136(62)	159(72)	149(68)	161(73)
90	132(60)	133(60)	158(72)	149(68)	160(73)
100/112	130(59)	132(60)	157(71)	147(67)	159(72)
132	186(84)	187(85)	166(75)	157(71)	169(77)
160	216(98)	271(123)	183(83)	219(99)	230(104)

14-d. Motor weight

Refer to motor manufacturer's catalog for motor weights.

15. SPECIFICATIONS

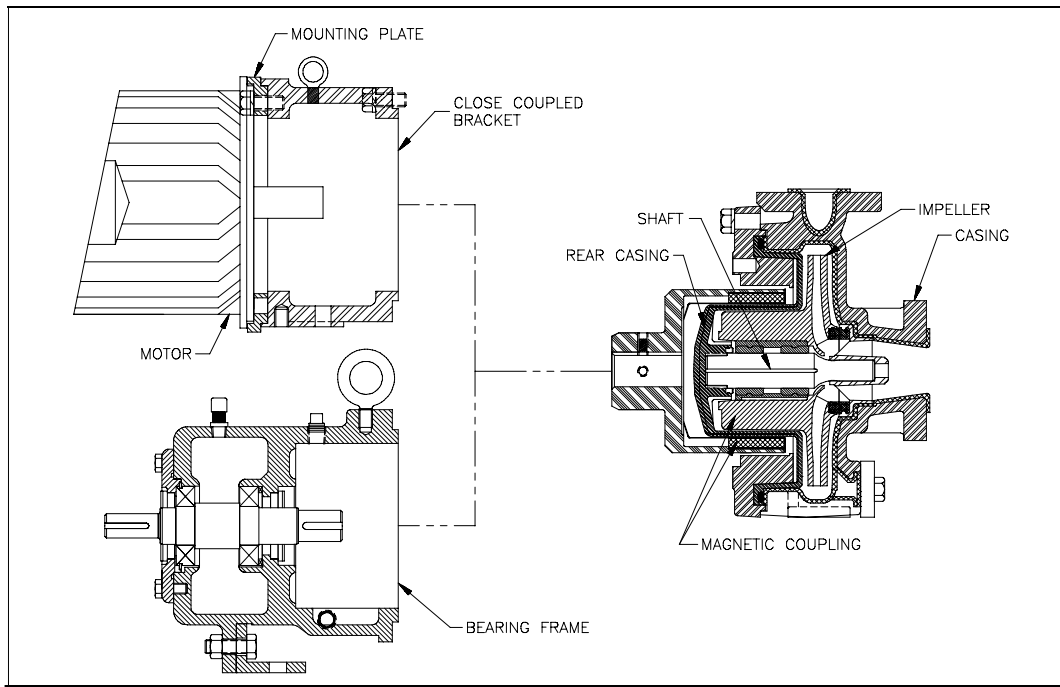

PUMP

- Horizontal End-Suction, Centerline discharge, Mag-drive Centrifugal pump.
- Synchronous drive, magnetically coupled for zero leakage applications.
- Non-metallic wetted parts.
- Meets ASME/ANSI B73.3 dimensional specification for flange and foot position (close and long coupled).
- Meets ISO 2858 dimensional specifications for flange and foot position (long coupled, only).
- Meets JIS B8313 dimensional specifications for flange position and foot position (long coupled, only).
- Maximum power, 30 hp (22 kW) at 3500 rpm.
- Back pull out design.
- Exterior protection: polyamide epoxy primer with polyurethane top coat (green).
- Slurry: 5% wt. 0.005 inch (150 microns) max.
- Maximum diameter solids: 1/32 inch (0.8 mm) max.
- Max. vapor pressure: consult factory for liquids with vapor pressure curve that passes above 8 psia (0.54 Bar) @ 90°F (32°C).
- Maximum viscosity: *

K1516	(Ki32160)	(Kj40160)	700 SSU	(150 centistokes)
K3156/K326s/K326	(Ki50160)	(Kj50160)	1200 SSU	(260 centistokes)
K436	(Ki65160)	(Kj65160)	1700 SSU	(365 centistokes)
K1518	(Ki32200)	(Kj40200)	750 SSU	(160 centistokes)
K3158	(Ki40200)	(Kj50200)	750 SSU	(160 centistokes)

- Minimum flow: **

K1516	(Ki32160)	(Kj40160)	3 gpm at 3600 rpm	(.68 m ³ /h at 2900 rpm)
K3156/ K326s/K326	(Ki50160)	(Kj50160)	5 gpm at 3600 rpm	(1.13 m ³ /h at 2900 rpm)
K436	(Ki65160)	(Kj65160)	5 gpm at 3600 rpm	(1.13 m ³ /h at 2900 rpm)
K1518	(Ki32200)	(Kj40200)	5 gpm at 3600 rpm	(1.13 m ³ /h at 2900 rpm)
K3158	(Ki40200)	(Kj50200)	5 gpm at 3600 rpm	(1.13 m ³ /h at 2900 rpm)

* Note: Pump performance (flow, head and efficiency) will be greatly affected by the viscosity of liquid pumped. Maximum viscosities given above are approximate numbers. Please refer to the Hydraulic Institute's "Viscosity Correction" chart. A pump should not be used or should be used with caution if efficiency with viscous liquid is less than 50% of efficiency with water.

** Note: Minimum flow data based on water. Consult factory for other liquids.

PRESSURE & TEMPERATURE CAPABILITY

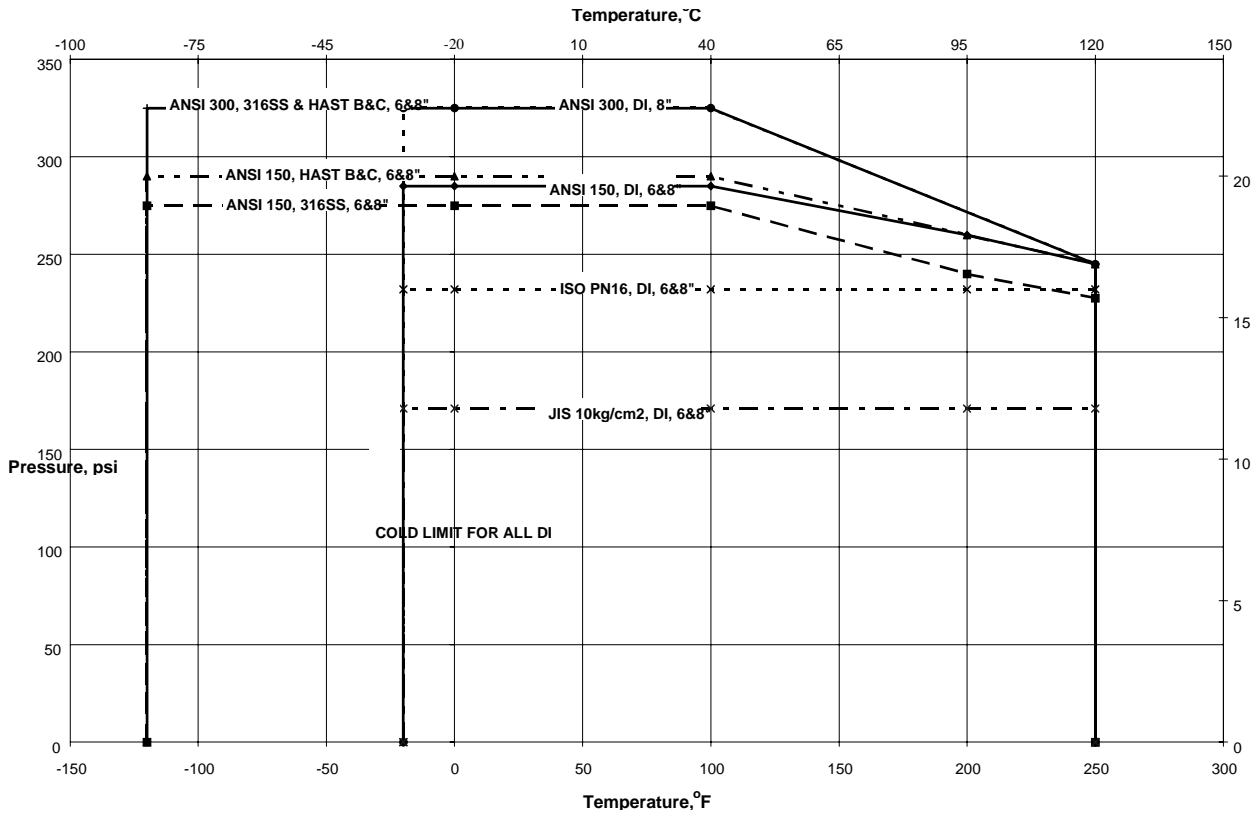

CASING

- Meets ANSI B73.3 or ISO 2858 or JIS B8313 foot and flange position and size standard
- Self-venting and top centerline discharge.
- Material: One piece solid ductile iron casing, lined with rotomolded ETFE fluoropolymer 1/8 in. (3 mm) min.
Optional (ANSI models, only): Alloy casing in 316 SS, Hastelloy® B or Hastelloy® C (no lining).
- Foot supported for maximum resistance to distortion from pipe loads.
- Pure sintered silicon carbide thrust ring integral with front shaft support.
- Flanges: ANSI/ASME B16.5 Class 150 or ISO 2084 Class NP 16 flanges standard.
Optional: ANSI/ASME B16.5 Class 300 on alloy casings, only.
- Casing drain connection standard.

IMPELLER

- Closed type, one piece construction
- Manufactured with carbon fiber filled ETFE fluoropolymer.
- Magnets fully encapsulated by ETFE fluoropolymer.
- Replaceable, press fit main bushing, either carbon/graphite or sintered silicon carbide.
- Replaceable, mouth ring, either carbon fiber filled PTFE or sintered silicon carbide.
- Optional glass fiber filled PFA.

SHAFT

- Non-rotating, 1.25" (32 mm) diameter.
- One piece, solid construction, sintered silicon carbide (SiC).
- Fully supported at both ends utilizing front shaft support and containment shell.
- Axial groove for improved lubrication and particulate bypass. U.S. Patented.

CONTAINMENT SHELL

- Exceeds ANSI/ASME B73.3 Pressure and Temperature Ratings for Class 150 flanges.
- Injection molded carbon fiber filled ETFE fluoropolymer backed by non-metallic reinforcement.
- Integral carbon fiber filled PTFE back thrust ring standard, optional sintered silicon carbide.
- No energy losses due to eddy currents from magnetic coupling.
- Fully confined casing O-ring.
- Burst pressure, 1800 psi (124 bar) & 2000 psi (138 bar) for 6" and 8" models, respectively.
- Optional glass fiber filled PFA.

MAGNETIC COUPLING

- Neodymium Iron Boron for maximum torque.
- Designed for zero slippage and zero losses.
- Utilizes standard NEMA or IEC motors.
- Eliminates soft start devices.
- Ratings:

A-drive: 10 HP / 7.5 kW max @ 3500 rpm; 5 HP / 3.75 kW max @ 1750 rpm
A-drive: 5.5kW / 7.5 HP max @ 2900 rpm; 3.0 kW / 4 HP max @ 1450 rpm
B-drive: 15 HP / 11 kW max @ 3500 rpm; 7.5 HP / 5.5kW max @ 1750 rpm
B-drive: 7.5 kW / 10 HP max @ 2900 rpm; 4.0 kW / 5 HP max @ 1450 rpm
C-drive: 30 HP / 22 kW max @ 3500 rpm; 15 HP / 11kW max @ 1750 rpm
C-drive: 18 kW / 24 HP max @ 2900 rpm; 9 kW / 12 HP max @ 1450 rpm

Note: Limit max. temperature to 200°F (93°C) above 25 hp @ 3500 rpm

CLOSE COUPLED BRACKET

- Provides metal-to-metal fit to casing and motor.
- No alignment between motor flange and pump.
- Eliminates the flexible coupling and bearing frame.
- Drilled and tapped for leak monitoring sensor (3/8 NPT).

BEARING FRAME

- Group 1 ASME/ANSI B73.1-1991 dimensional.
- L₁₀ life of 30,000 hours.
- Large oil reservoir for cool operation and long oil life.
- Sight window for direct oil level indication.
- Sealed enclosure provides secondary containment (optional).
- Drilled and tapped for leak monitoring sensor (3/8 NPT).

16. COMMON CONVERSIONS

Flow (capacity)

gpm (US)	m ³ /h	l/min	gpm (UK)
1	0.2271	3.785	0.8327
4.403	1	16.6	3.666
0.2642	0.06	1	0.2200
1.201	0.2727	4.5458	1

$$\text{GPM (US)} \times 0.2271 = \text{m}^3/\text{h}$$

$$\text{l/min} \times 0.2642 = \text{GPM (US)}$$

$$\text{m}^3/\text{h} \times 4.403 = \text{GPM (US)}$$

$$\text{GPM (US)} \times 3.785 = \text{l/min}$$

$$\text{m}^3/\text{h} \times 16.6 = \text{l/min}$$

$$\text{l/min} \times 0.06 = \text{m}^3/\text{h}$$

Head (pressure / vacuum)

Ft (H ₂ O)	m (H ₂ O)	PSI	Kg/cm ²	KPa	inch Hg	mmHg	bar
1	0.3048	0.4335	0.03048	2.989	0.8851	22.48	0.02987
3.281	1	1.422	0.100	9.807	2.904	73.76	0.3685
2.307	0.7031	1	0.07031	6.895	2.042	51.87	0.0690
32.83	10.01	14.23	1	98.07	29.04	737.6	3.685
0.3349	0.1020	0.1450	0.01020	1	0.2961	7.521	0.01
1.132	0.3450	0.491	0.03443	3.377	1	25.4	0.0339
0.04457	0.5339	0.01933	0.001356	0.1330	0.03937	1	0.005
33.5	2.714	14.50	0.2714	100	29.5	200	1

$$\text{Ft (in water)} \times 0.3048 = \text{m (in water)}$$

$$\text{PSI} \times 2.307 = \text{Ft (in water)}$$

$$\text{m (in water)} \times 3.2808 = \text{Ft (in water)}$$

$$\text{Ft (in water)} \times .433 = \text{PSI}$$

$$\text{Kg/cm}^2 \times 0.328 = \text{Ft (in water)}$$

$$\text{PSI} \times 6.895 = \text{KPa}$$

$$\text{Ft (in water)} \times 3.049 = \text{Kg/cm}^2$$

$$\text{KPa} \times 0.1450 = \text{PSI}$$

Volume

Ft ³	m ³	liter	gallon (US)	gallon (UK)	Lbs of water
1	0.02832	28.32	7.481	6.229	62.44
35.31	1	1000	264.2	220.00	2205
0.03531	0.001	1	0.2642	0.2200	2.204
0.1337	0.003785	3.785	1	0.8327	8.347
0.1606	0.004545	4.548	1.201	1	10.025
0.01620	0.0004537	0.4537	.1198	0.09975	1

Temperature Conversions

°F	°C	°F	°C	°F	°C	°F	°C	°F	°C	°F	°C	°F	°C	°F	°C	Δ°F	Δ°C
-60	-51	0	-18	60	15.6	120	48.9	180	82.2	240	116	300	149	360	182	1	0.6
-55	-48	5	-15	65	18.3	125	51.7	185	85.0	245	118	305	152	365	185	2	1.1
-50	-46	10	-12	70	21.1	130	54.4	190	87.8	250	121	310	154	370	188	3	1.7
-45	-43	15	-9.4	75	23.9	135	57.2	195	90.6	255	124	315	157	375	191	4	2.2
-40	-40	20	-6.7	80	26.7	140	60.0	200	93.3	260	127	320	160	380	193	5	2.8
-35	-37	25	-3.9	85	29.4	145	62.8	205	96.1	265	129	325	163	385	196	6	3.3
-30	-34	30	-1.1	90	32.2	150	65.6	210	98.9	270	132	330	166	390	199	7	3.9
-25	-32	35	1.67	95	35.0	155	68.3	215	102	275	135	335	168	395	202	8	4.4
-20	-29	40	4.44	100	37.8	160	71.1	220	104	280	138	340	171	400	204	9	5.0
-15	-26	45	7.22	105	40.6	165	73.9	225	107	285	141	345	174	405	207	10	5.6
-10	-23	50	10.0	110	43.3	170	76.7	230	110	290	143	350	177	410	210	11	6.1
-5	-21	55	12.8	115	46.1	175	79.4	235	113	295	146	355	179	415	213	12	6.7

$$^{\circ}\text{F} = (9/5) \text{C} + 32$$

$$^{\circ}\text{C} = (5/9) \times (^{\circ}\text{F} - 32)$$

ADDENDUM 1 - VERSA-TOOL FOR SHAFT SUPPORT

VERSA-TOOL INSTRUCTION MANUAL

1. ASSEMBLING THE SHAFT SUPPORT

Insert the threaded shaft of Item 4 into the center hole of Item 2. Turning clockwise, screw Item 4 onto Item 2 until it protrudes approximately 1" from the other side of Item 2. Screw on the 5/8" acorn nut (1 pc.) onto Item 4. Select the shaft support adapter which corresponds to the shaft support to be installed. Push Item 1 onto the unthreaded end of Item 4. Insert the shaft support thrust ring side first onto Item 4 until it rests against Item 1. Bolt the Versa-tool into the casing. To press in the shaft support, turn the acorn nut (Item 3) clockwise. Continue to turn until the shaft support is resting against the shoulder in the casing.

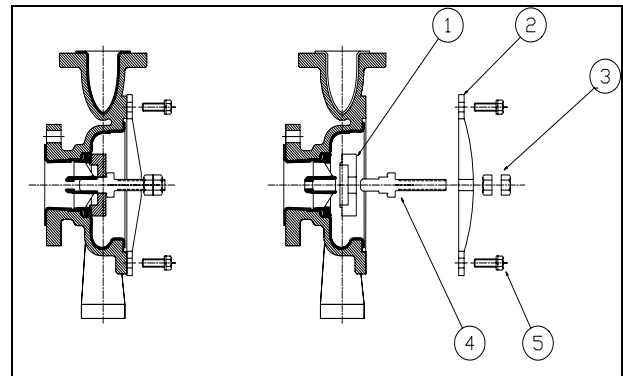

Fig. A2-1

2. EXTRACTING THE SHAFT SUPPORT

Slide Item 6 into the shaft support. Turn clockwise and pull back to engage the claws against the spokes on the shaft support. **Warning: To prevent damage to the shaft support, make sure Item 6 is fully engaged with the spokes on the shaft support.** Item 2 is designed to be used on 6" and 8" K Series and KM casings. Determine the type of casing and assemble Item 2 onto the threaded shaft of Item 6 until it rests flush against the back of the pump casing. (Note: these parts do not thread together as in Section 1, but should slide freely.) Align the bolt holes on Item 2 with any threaded holes in the casing and secure using Item 5 (2 pieces). Screw Item 7 onto Item 6 clockwise until it rests against Item 2. To extract the shaft support, continue turning Item 7. Item 6 will begin to pull forward, removing the shaft support with it. Continue turning until the shaft support is fully out from the casing.

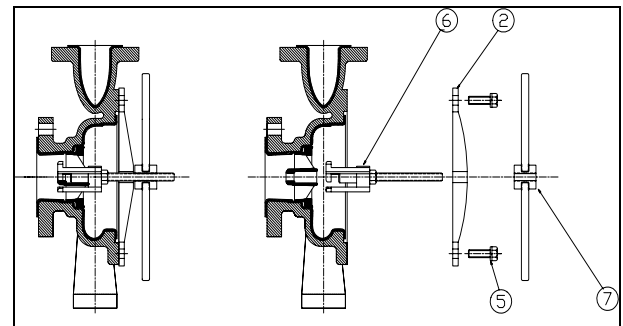

Fig. A2-2

3. MEASURE THE DEPTH OF THRUST RING

After assembling the shaft support, measure the depth between the thrust ring in the shaft support and the end of casing. Refer to Fig.A2-3 and the table below for the correct dimension. Measurements should be taken on at least (4) locations to ensure that the thrust ring is parallel with the face of the casing.

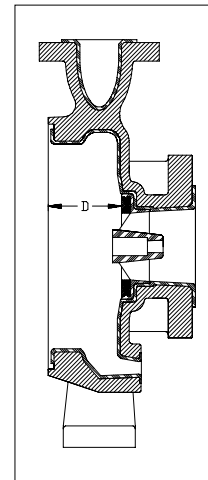

Fig. A2-3

K1516 1.5" x 1" x 6" D=2.425" +/- 0.015	K326 3" x 2" 6" D=2.563" +/-0.015	K436 4" x 3" x 6" D=3.000" +/-0.015	K1518 1.5" x 1" x 8" D=2.850" +/-0.015	K3158 3" x 1.5" x 8" D=3.057" +/-0.015
--	--	--	---	---

Ki32160 50mm x 32mm x 160mm D=74.3mm +/-0.38	Ki50160 65mm x 50mm x 160mm D=77.8mm +/-0.38	Ki65160 100mm x 65mm x 160mm D=89.7mm +/-0.38	Ki32200 50mm x 32mm x 200mm D=72.4mm +/-0.38	Ki40200 65mm x 40mm x 200mm D=77.6mm +/-0.38
--	--	---	--	--

ADDENDUM 2 – Inactive Parts

(Inactive) A-drive, 10hp/3600, 5hp/1800		P2842A	P2843A	P2844A	K0211	K0214
(Inactive) B-drive, 15hp/3600, 7.5hp/1800		P2842B	P2843B	P2844B	K0212	K0215
(Inactive) C-drive, 30hp/3600, 15hp/1800		P2842C	P2843C	P2844C	K0213	K0216
(Inactive) A-drive, 7.5 KW/3500, 3.75KW/1750, 5.5KW/2900, 3.0KW/1450		P2842A	P2843A	P2844A	K0211	K0214
(Inactive) B-drive, 11KW/3500, 5.5KW/1750, 7.5KW/2900, 4.0KW/1450		P2842B	P2843B	P2844B	K0212	K0215
(Inactive) C-drive, 22KW/3500, 11KW/1750, 18.5KW/2900, 9KW/1450 ¹		P2842C	P2843C	P2844C	K0213	K0216

ANSIMAG, 14845 W. 64th Avenue, Arvada, CO 80007, USA
Phone: (303)425-0800 Fax: (303)425-0896
www.Sundyne.com
K+ Installation&Maintenance, January 2007