

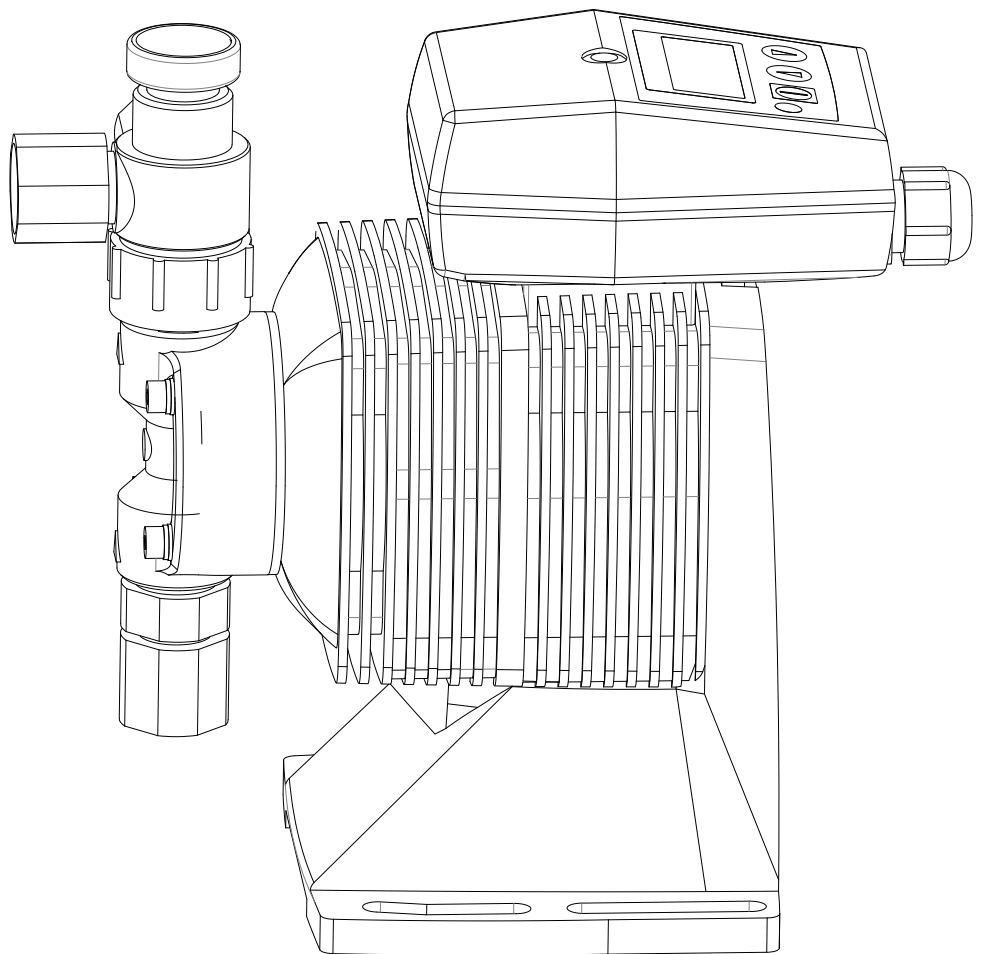

EZ Series Electronic Metering Pump Instruction Manual



Five Boynton Road Hopping Brook Park Holliston, MA 01746 USA

TEL: 508-429-1110 WEB: www.walchem.com

Notice

© 2016 WALCHEM, Iwaki America Inc. (hereinafter “Walchem”)
Five Boynton Road, Holliston, MA 01746 USA
tel (508) 429-1110 fax (508) 429-7433
All Rights Reserved
Printed in USA

Proprietary Material

The information and descriptions contained herein are the property of WALCHEM. Such information and descriptions may not be copied or reproduced by any means, or disseminated or distributed without the express prior written permission of WALCHEM.

This document is for information purposes only and is subject to change without notice.

Statement of Limited Warranty

WALCHEM warrants equipment of its manufacture and bearing its identification to be free from defects in workmanship and material for a period of two years from date of delivery from the factory or authorized distributor under normal use and service and otherwise when such equipment is used in accordance with instructions furnished by WALCHEM and for the purposes disclosed in writing at the time purchased, if any. WALCHEM’s liability under this warranty shall be limited to replacement or repair, F.O.B. Holliston, MA U.S.A. of any defective equipment or part which, having been returned to WALCHEM, transportation charges prepaid, has been inspected and determined by WALCHEM to be defective.

THIS WARRANTY IS IN LIEU OF ANY OTHER WARRANTY, EITHER EXPRESS OR IMPLIED, AS TO DESCRIPTION, QUALITY, MERCHANT-ABILITY, FITNESS FOR ANY PARTICULAR PURPOSE OR USE, OR ANY OTHER MATTER.

P/N E00159.M
January 2017

TABLE OF CONTENTS

Thank you for choosing a Walchem EZ Series metering pump. This instruction manual deals with the correct installation, operation, maintenance and troubleshooting procedures for the EZ metering pumps. Please read through it carefully to ensure the optimum performance, safety and service of your pump.

Contents

1.0 INTRODUCTION	1
1.1 Safety and Caution Notes	1
1.2 Principle of Operation	1
1.3 Model Code	2
1.4 Specifications	2
1.4.1 Electrical	2
1.4.2 Operating Conditions	2
1.4.3 Capacity/Pressure Rating	3
1.4.4 Adjustment Range	3
1.4.5 Materials of Construction	3
1.5 Dimensions	4
2.0 INSTALLATION	6
2.1 Unpacking	6
2.2 Location	6
2.3 Supply Tubing	7
2.4 Discharge Tubing	8
2.5 Installing Injection/BackPressure Valve	8
2.6 Interlocking Pump	9
2.7 Electrical	9
3.0 OPERATION	9
3.1 Priming	9
3.2 Adjustment and Control	10
3.3 Calibration	13
3.4 STOP Function	13
3.5 AC Power Interruption	13
3.6 Auto Air Vent Valve Operation	14
3.7 MultiFunction Valve Operation	14
4.0 MAINTENANCE	16
4.1 Diaphragm Replacement	16
4.2 Valve Replacement	16
4.3 Tubing	16
5.0 EXPLODED VIEW & PARTS GUIDE	17
6.0 TROUBLESHOOTING	27
7.0 SERVICE POLICY	27

1.0 INTRODUCTION

1.1 Safety and Caution Notes



Always wear protective clothing, eye protection and gloves before working on or near a metering pump. Follow all recommendations of the supplier of the solution being pumped. Refer to the MSDS from the solution supplier for additional precautions.

Walchem EZ Series metering pumps should be installed where ambient temperatures do not exceed 122°F (50°C) or do not fall below 32°F (0°C). Pumps should always be shielded from direct exposure to the elements. Black UV resistant tubing should be used if the tubing is exposed to strong UV radiation (sunlight/lamps).



WARNING Risk of electrical shock! This pump is supplied with a grounding conductor and grounding-type attachment plug. To reduce the risk of electrical shock, be certain that it is connected only to a properly grounded, grounding type receptacle with ratings conforming to the data on the pump data plate. Prior to performing any maintenance on a pump, disconnect the pump from the electrical power source.

Plumbing Precautions

All tubing must be securely attached to the fittings prior to starting the pump (see Section 2.3). Only use Walchem tubing with your pump. Tubing should be shielded to prevent possible injury in case of rupture or damage. UV resistant tubing should be used if the tubing is exposed to UV light. Always adhere to local plumbing codes and requirements. Be sure that the installation does not constitute a cross connection. Walchem is not responsible for improper installations. Prior to performing any maintenance on a pump, depressurize the discharge tubing.

In flooded suction, pumping downhill, or pumping into little or no system pressure installations, a back pressure/anti-syphon device must be installed to prevent over-pumping or siphoning. Contact your Walchem distributor for additional information.

Solution Compatibility

CAUTION! This pump has been evaluated for use with water only. The suitability of this pump for use with liquids other than water (such as acids or alkalines) is the responsibility of the user. For liquids other than water, select the best-suited liquid end material combination using a chemical compatibility chart.

1.2 Principle of Operation

The EZ series electronic metering pumps consist of a pump unit, a drive unit, and a control unit. The drive unit is an electromagnetic solenoid. When the solenoid coil is energized by the control unit the armature shaft moves forward due to the magnetic force of the solenoid. The shaft is attached to a PTFE faced diaphragm which is part of the pump unit. The diaphragm is forced into the pump head cavity decreasing volume and increasing pressure which forces liquid in the pump head out through the discharge check valves. When the solenoid coil is de-energized, a spring returns the armature to its starting position. This action pulls the diaphragm out of the head cavity increasing volume and decreasing pressure. Atmospheric pressure then pushes liquid from the supply tank through the suction check valves to refill the pump head.

1.3 Model Code

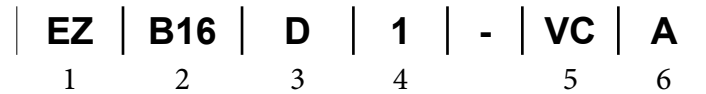

1 Pump Series

EZ: Electronic metering pump with manual speed control (adjustable to 360 strokes per minute)

2 Capacity/Pressure Rating (See Section 1.4 for detailed chart.)

3 Control Module

D: For use on all EZ models, features digitally adjustable speed and fixed stroke length

T: Timer module allows daily, weekly, or 2 week operation with digitally adjustable speed and external stop control. Available on 115V EZB models.

4 Voltage

1: 115 VAC, 50/60 Hz

2: 230 VAC, 50/60 Hz (not available on EZB pumps)

5 Liquid End (See Section 1.45 for detailed chart.)

6 Options

M: Multifunction Valve is supplied in place of the manual air vent valve. Available for the EZ series pumps in all sizes and liquid ends except FC. Not available with the ADV feature.

A Auto Degassing Valve is supplied under the manual air vent valve. Available for the EZ Series in B11/16/21 and C16/21 sizes with -VC/-VE liquid ends only.

1.4 Specifications

1.4.1 Electrical

(50/60 Hz, single phase)

EZB	115 VAC±10%	0.9 Amp max.	16 watt avg.
EZC	115 VAC±10%	1.4 Amp max.	24 watt avg.
	230 VAC±10%	0.6 Amp max.	24 watt avg.

1.4.2 Operating Conditions

Ambient temperature	32°F to 122°F (0°C to 50°C)
Relative humidity	30% to 90% non-condensing
Liquid temperature	32° to 104°F (0 to 40°C) for PVC based liquid ends 32° to 140°F (0 to 60°C) for PP, PVDF, SS based liquid ends

1.4.3 Capacity/Pressure Rating

Size	Maximum Output Capacity		Max Output per Stroke (mL)	Maximum Pressure ¹		Connection Size (in) Tubing O.D
	(Gal/hr)	(mL/min)		PSI	MPa	
B11	0.6	38	0.11	150	1.0	3/8
B16	1.0	65	0.18	105	0.7	3/8
B21	1.5	95	0.26	60	0.4	3/8
B31	3.2	200	0.56	30	0.2	1/2
C16	1.3	80	0.22	150	1.0	3/8
C21	2.0	130	0.36	105	0.7	3/8
C31	4.3	270	0.75	50	0.35	1/2
C36	6.3	400	1.17	30	0.2	1/2

¹ Auto Degassing valve reduces output by approx. 20%

1.4.4 Adjustment Range

Frequency adjustment range: 0 to 360 strokes per minute

1.4.5 Materials of Construction

Liquid End Code	Pump Head & Fittings	Diaphragm	Valve Balls	Valve Seat	Valve Seals	Gasket	Tubing
PA	GFRPP	PTFE (bonded to EPDM)	CE	PCTFE	AFLAS®	PTFE	PE
PC	GFRPP		CE	FKM	FKM		
PE	GFRPP		CE	EPDM	EPDM		
VC	PVC		CE	FKM	FKM		
VE	PVC		CE	EPDM	EPDM		
VF	PVC		PTFE	EPDM	EPDM		
TA	PVDF		CE	PCTFE	AFLAS®		
TC	PVDF		CE	FKM	FKM		
FC	PVDF		CE	PCTFE	PTFE		

CE Alumina ceramic
 EPDM Ethylene propylene diene monomer
 FKM Fluoroelastomer
 GFRPP Glass fiber reinforced polypropylene
 PCTFE Polychlorotrifluoroethylene

PE Polyethylene
 PTFE Polytetrafluoroethylene
 PVC Polyvinylchloride (translucent)
 PVDF Polyvinylidene fluoride

1.5 Dimensions

EZB Models with thermoplastic liquid end materials (except -FC)

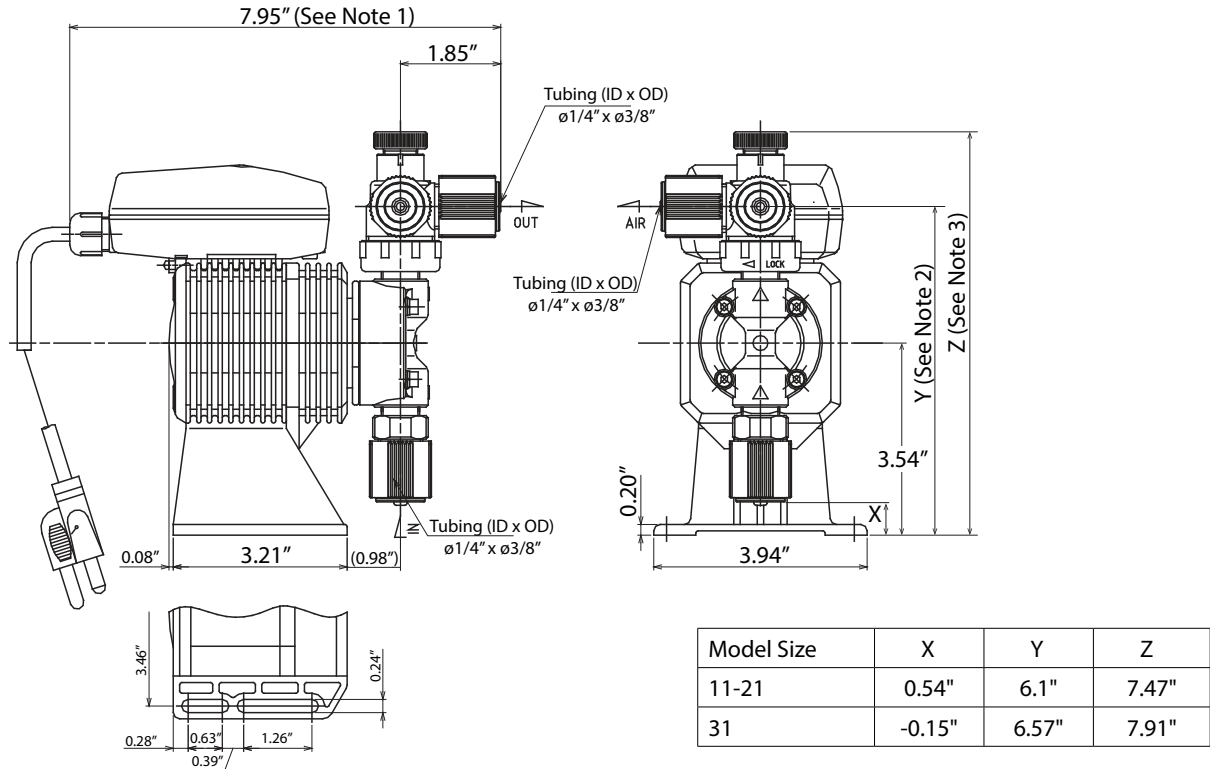

Notes:

1. Addition of a Multifunction valve increases overall length by 0.10".
2. Addition of a Multifunction Valve increases discharge height by 2.62". The Auto Degassing Valve increases discharge height by 1.82".
3. Addition of a Multifunction Valve increases overall liquid end height by 1.25". The Auto Degassing Valve increases height by 1.82".

EZB Models with FC liquid end materials

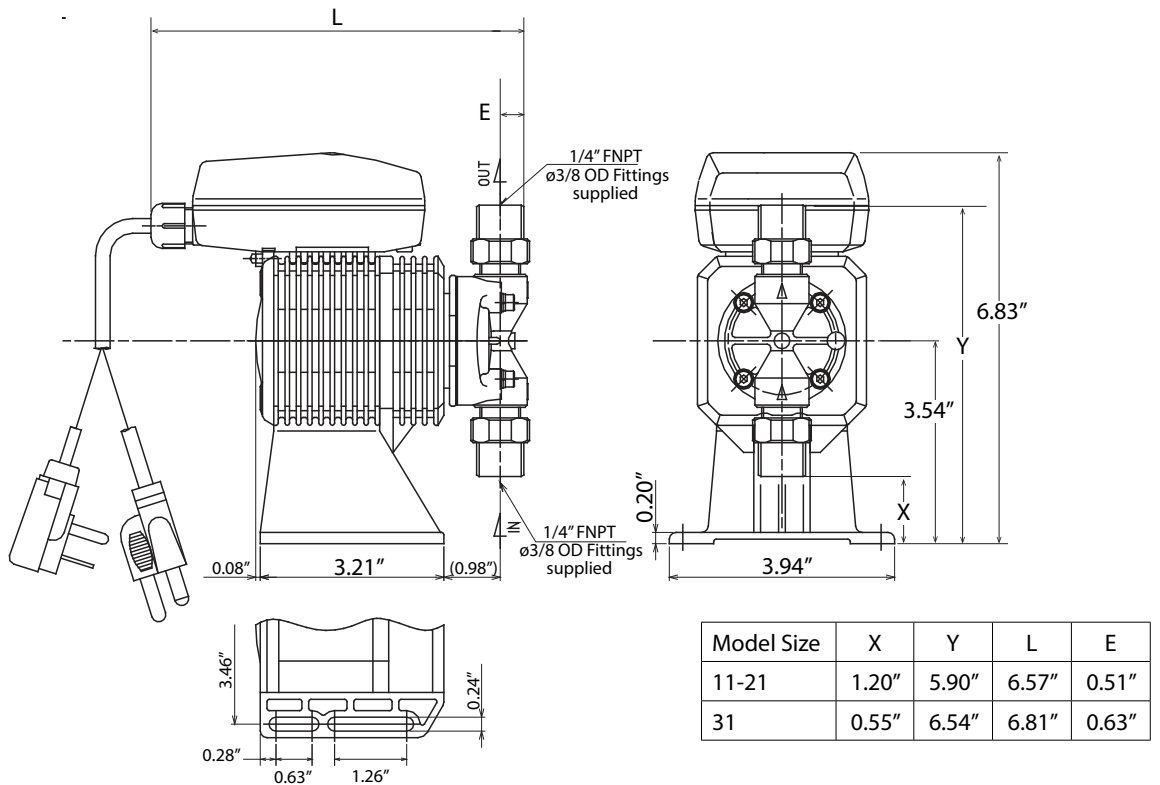

EZC Models with thermoplastic liquid end materials (except FC)

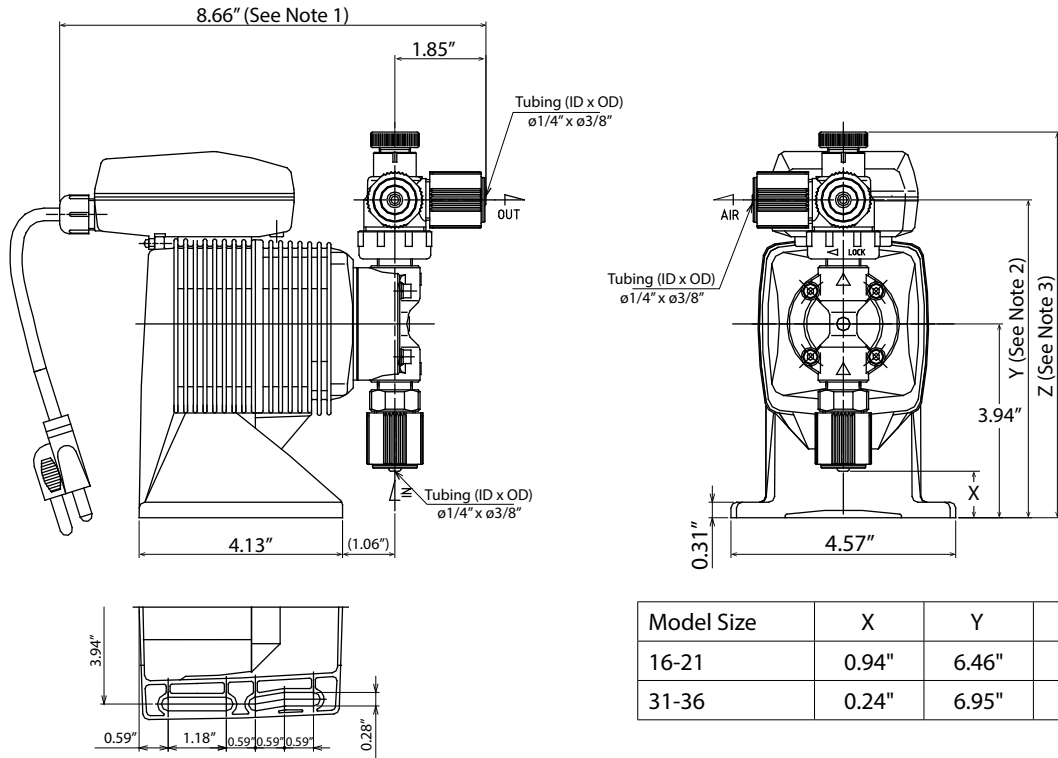

Notes:

1. Addition of a Multifunction valve increases overall length by 0.10".
2. Addition of a Multifunction Valve increases discharge height by 2.62". The Auto Degassing Valve increases discharge height by 1.82".
3. Addition of a Multifunction Valve increases overall liquid end height by 1.25". The Auto Degassing Valve increases height by 1.82"

EZC Models with FC liquid end materials

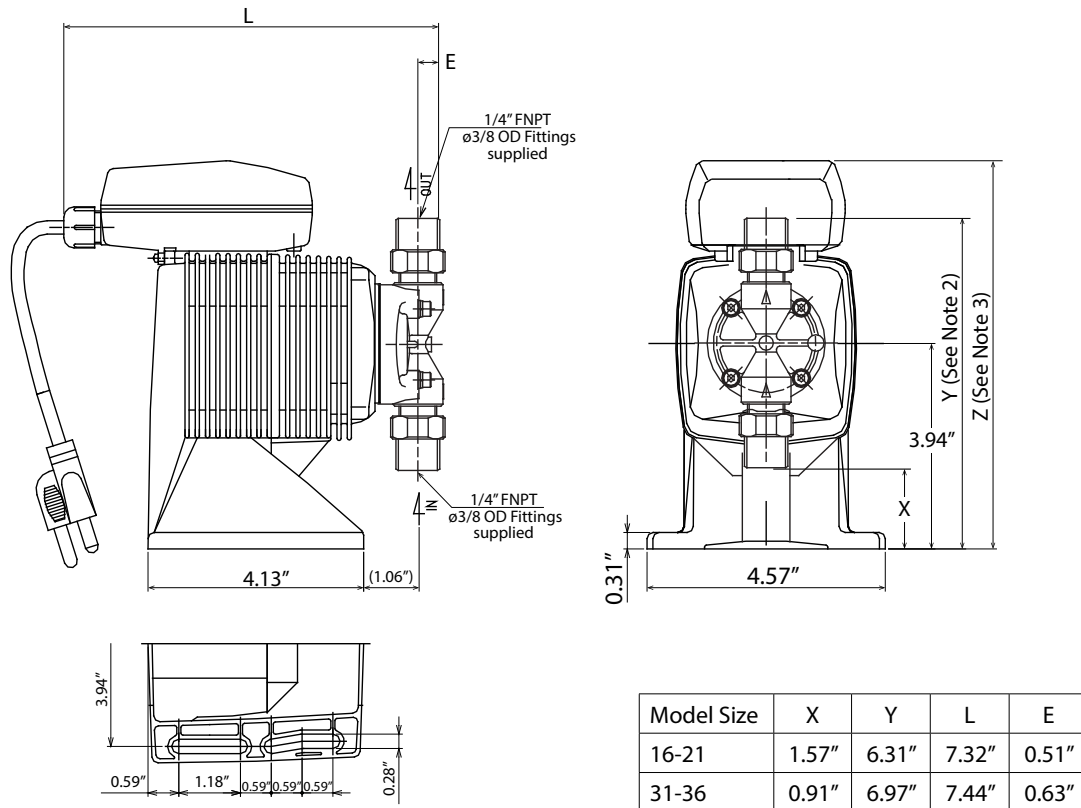

2.0 INSTALLATION

2.1 Unpacking

Open the shipping carton and inspect contents for damage. If any items are missing or damaged contact your local distributor.



Pumps are pre-primed with water at the factory. If the application is not compatible with water, drain and dry before use. Be sure to remove caps from fittings before attaching tubing.

CAUTION: Head bolts may have loosened during storage or shipment. Be sure to check and tighten to 19 lb-in torque, if necessary.

Do not handle or move the pumps using the Control Module only. The pump should be supported by the base or drive unit during handling

2.2 Location

Choose a location for the pump which is clean, dry, vibration-free, close to an electrical outlet, and allows convenient access to stroke length control, frequency control, and tubing connections. Avoid areas where ambient temperature exceeds 122°F (50°C) or falls below 32°F (0°C). Pumps should always be shielded from direct exposure to the elements. Black UV resistant tubing should be used if the tubing is exposed to strong UV radiation (sunlight/lamps).

This pump is cord connected and not intended for permanent mounting to a building structure. However, temporary mounting to stabilize the pump during operation may be necessary as long as tools are not required for the installation or removal of the pump.

Flooded suction (mounting the pump below the level of liquid in the supply tank) is strongly recommended, especially when pumping liquids that readily generate gas bubbles. Sodium hypochlorite and hydrogen peroxide are common examples of such liquids. (See Figure 1.)

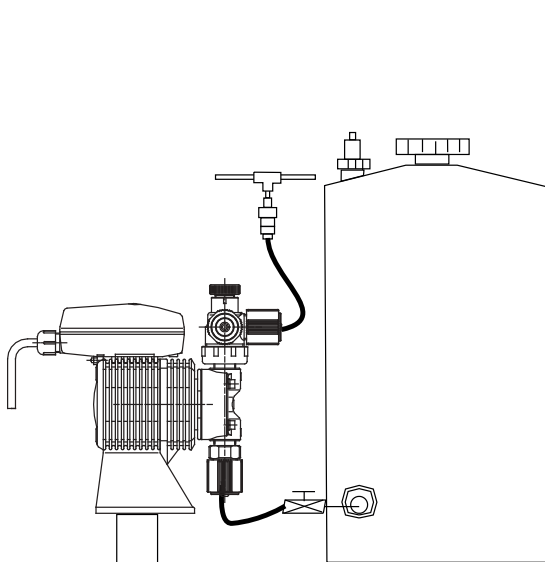

Figure 1 Flooded suction
Recommended for liquids
that out-gas

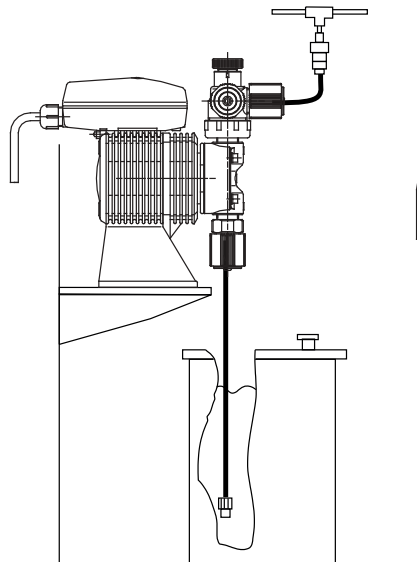

Figure 2 Shelf mount

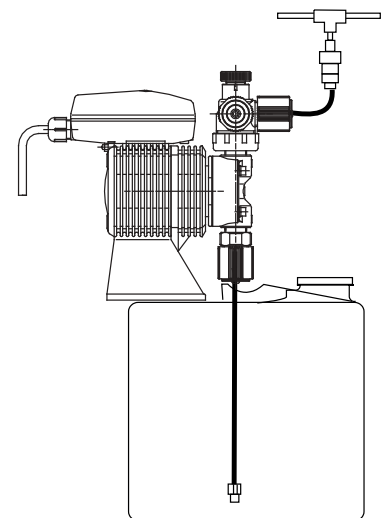

Figure 3 Tank mount

If flooded suction mounting is not possible, a shelf adjacent to (but not directly above) the supply tank often works well. (See Figure 2.) The supply tank or cover can also be used if it has provisions for mounting a pump. (See Figure 3.) In any case, the total suction lift should not exceed 5 ft (1.5m).

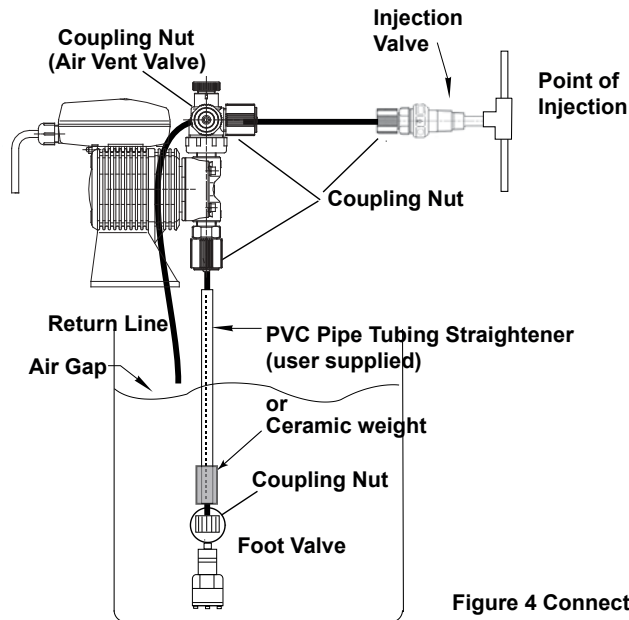

Figure 4 Connection Tubing

2.3 Supply Tubing

The supply tubing run should be as short as possible. For flooded suction mounting, install a shut-off valve with an appropriate tubing connector at the tank outlet. Cut a length of tubing from the coil supplied and install between the shut-off valve and the pump inlet fitting. For suction lift applications, slide on the ceramic weight, then install a foot valve on one end of suction tubing. Cut the tubing to a length such that the foot valve hangs vertically about 1 in (25mm) above the bottom of the tank. Avoid any loops in the tubing run that could form a vapor trap. Running the tubing through a length of pipe will help to keep tubing straight. Total vertical suction lift should be no more than 5ft. (1.5m). Reference Figure 4.

Attach tubing as shown in Figure 5. First slide the coupling nut, small end first, then the tubing clamp onto the tubing. Push the tubing over the tubing adapter tip all the way to the valve housing shoulder. (Tip: if the tubing is stiff from cold, dip the tubing end in hot tap water for a few minutes so it will slide on and flare out more easily. Push the tubing adapter into the fitting on the pump and coupling nut onto the threads. Apply some pressure on the coupling nut and tubing while tightening the nut, making sure the tubing has not backed off of the shoulder of the valve housing.

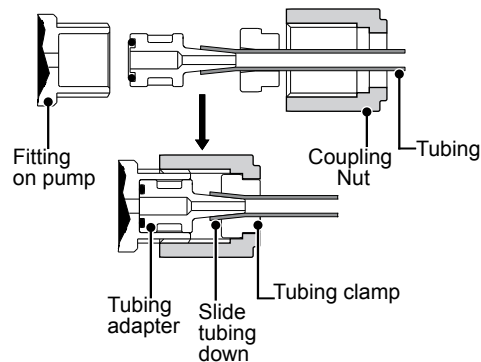

Figure 5

WARNING: All fittings and coupling nuts should be tightened by hand only. If necessary, a small tool may be used to make it snug. DO NOT use excessive force or large wrenches.

The coupling nut should not bottom out completely against the fitting. If this happens during connection, check the tubing and tubing clamp connection. Remove the coupling nut, re-cut the tubing and re-connect if necessary.

WARNING: If there is any leakage around the coupling nut and it appears to have been installed correctly, DO NOT TIGHTEN the coupling further! Release pressure in the line, disconnect tubing, re-cut and re-connect. Tightening of misinstalled tubing may cause the tubing to be cut off under pressure.

2.4 Discharge Tubing

Cut a length of tubing long enough to go from the pump to the application (injection) point. Additional tubing can be ordered from your distributor. Avoid sharp turns or bends and hot surfaces. Routing tubing through rigid pipe such as PVC pipe is recommended for long runs and/or as protective shielding against corrosive chemicals. If applicable, install the injection valve in 1/2" NPT thread at the injection point (see section 2.5) and connect the discharge tubing to the injection valve.

Attach tubing as described in section 2.3 and as shown in Figures 5 and 6. Note: Some models have an air vent valve with two outlet connections. The connection marked 'OUT' is the discharge side to the application point. (Fig 6). Attach a second length of tubing to the air vent side marked ('AIR') and route back to the chemical solution tank or drum. On the larger pumps (31 & 36 sizes), the air vent valve connections are not marked, however, the discharge side is the vertical (UP) connection and the air vent connection is on the side of the valve.

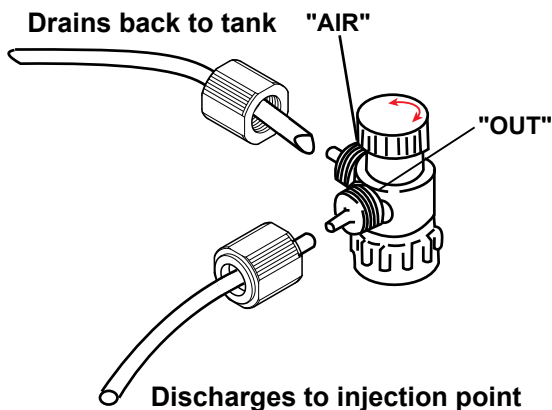

Figure 6 Air Vent Valve Tubing

2.5 Installing Injection/BackPressure Valve

A fitting or tee with 3/8" or 1/2" NPTF threads and with sufficient depth will accept the injection valve assembly. If required, trim off an amount of the extension tip until it fits your fitting or tee. (Fig. 7.)

The position of the injection/back pressure valve can be at any orientation as long as the spring is retained in the valve. **DO NOT REMOVE THE SPRING.** Be sure to check and replace the spring as needed. Attach the tubing following the same instructions in section 2.3, connecting the supply tubing.



CAUTION: Some chemicals may have reactions as they are injected into the main flow. For example, sulfuric acid may react with water causing excess heat. If the chemical is heavier than water, mount the injection valve as close as possible to vertical coming into the bottom of the pipe. This will keep the injection nozzle facing up and keep the heavier chemistry from draining into the pipe and causing adverse reactions within the injection valve and pipe.

In addition to preventing backflow from pressurized lines, the injection valve acts as a back pressure valve when pumping into atmosphere or low pressure applications. However, the back pressure by the injection valve can vary and the valve does NOT act as an anti-siphon valve. If siphoning is a possibility, or if pumping downhill into open atmosphere (open tank), a Walchem MultiFunction valve or a separate back pressure/anti-siphon valve must be installed.

Note: Siphoning can also occur at the tip of the injection valve because of the high flow rate in the main pipe flowing past the small injection nozzle (venturi effect). In this case, an anti-siphon device must be installed to avoid over feeding or siphoning of chemistry. See Section 5.0 for complete liquid ends parts list and exploded view.

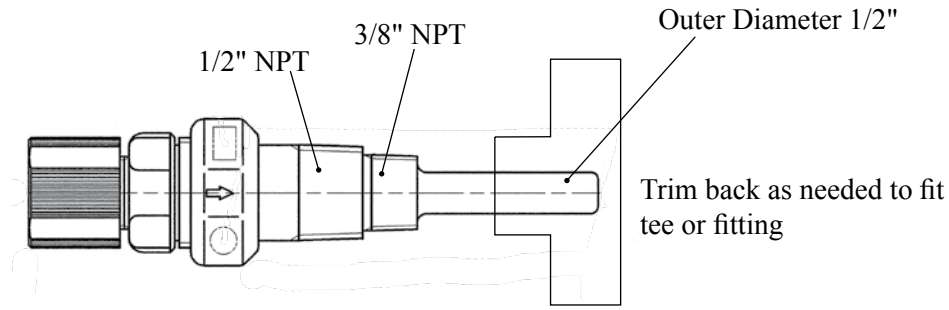

Figure 7 Injection Valve

2.6 Interlocking Pump



CAUTION! Control of pump operation is critical. Operation and chemical addition during no flow situations can create hazardous situations from elevated chemical concentrations and chemical gasses trapped in the line.

Ensure that during no flow conditions such as when the well pump, main line or recirculation pump is off, and for pools/spas, in times of backwash, that the metering pump is not allowed to operate. If using a controller (pH/ORP/pool) for automated control and flow indication is tied into it, pump operation can be interlocked to the controller.

Interlocking the pump operation can also be done directly using a flow switch located in the water, main or pool/spa recirculation lines. The flow switch can be tied directly into the pumps to stop operation during no flow conditions.

2.7 Electrical



WARNING Risk of electrical shock! This pump is supplied with a grounding conductor and ground-ing-type attachment plug. To reduce the risk of electrical shock, be certain that it is connected only to a properly grounded, grounding type receptacle.



CAUTION! The electronics within the pump can be damaged by excessive surges in voltage. Do not install the pump near high-power electrical equipment that generate high surge voltages. Avoid branch circuits that also supply power to heavy or other equipment that could generate electrical interference. If necessary, install a surge suppression device (such as a varistor with a resistance greater than 2000A) or a noise reducing transformer at the pump's power connection.

3.0 OPERATION

3.1 Priming

Install the pump as described above. With the pump turned on, set frequency at 100%. If the pump is equipped with an air vent valve, open the knob 1/2 turn. Liquid should move through the suction tubing and into the pump head. When liquid starts running through the vent side tubing, close the air vent knob and continue with output adjustment described below. If the pump has no air vent valve, disconnect the discharge tubing from the injection valve. When liquid enters the discharge tubing at the pump head, stop the pump. Then reconnect the discharge tubing to the injection valve.

If the pump does not self prime, remove the check valve housing on discharge & suction sides to make sure valve cartridges and gaskets are in correct positions (see section 4.2 for correct orientation).

Note: It is recommended that pumps with FC liquid ends use flooded suction when priming, due to the hard valve seat material.

3.2 Adjustment and Control

3.2.1 EZ Pumps using the 'D' Control Module

If less than full output is required, set the frequency to the appropriate percentage of maximum desired.

Example: Model EZB21D1-VE has maximum output of 1.5 GPH.

Desired output is 1.2 GPH. $1.2 \div 1.5 = 0.8$ or 80%

Set the frequency of the pump to $0.8 \times 360 = 288$ spm by pushing the UP or DOWN arrow keys.

3.2.2 EZ Pumps using the 'T' Control Module

The EZB-Timer Series is able to operate in Daily, Weekly and 2-Week modes. An external stop input and 12VDC output are also available.

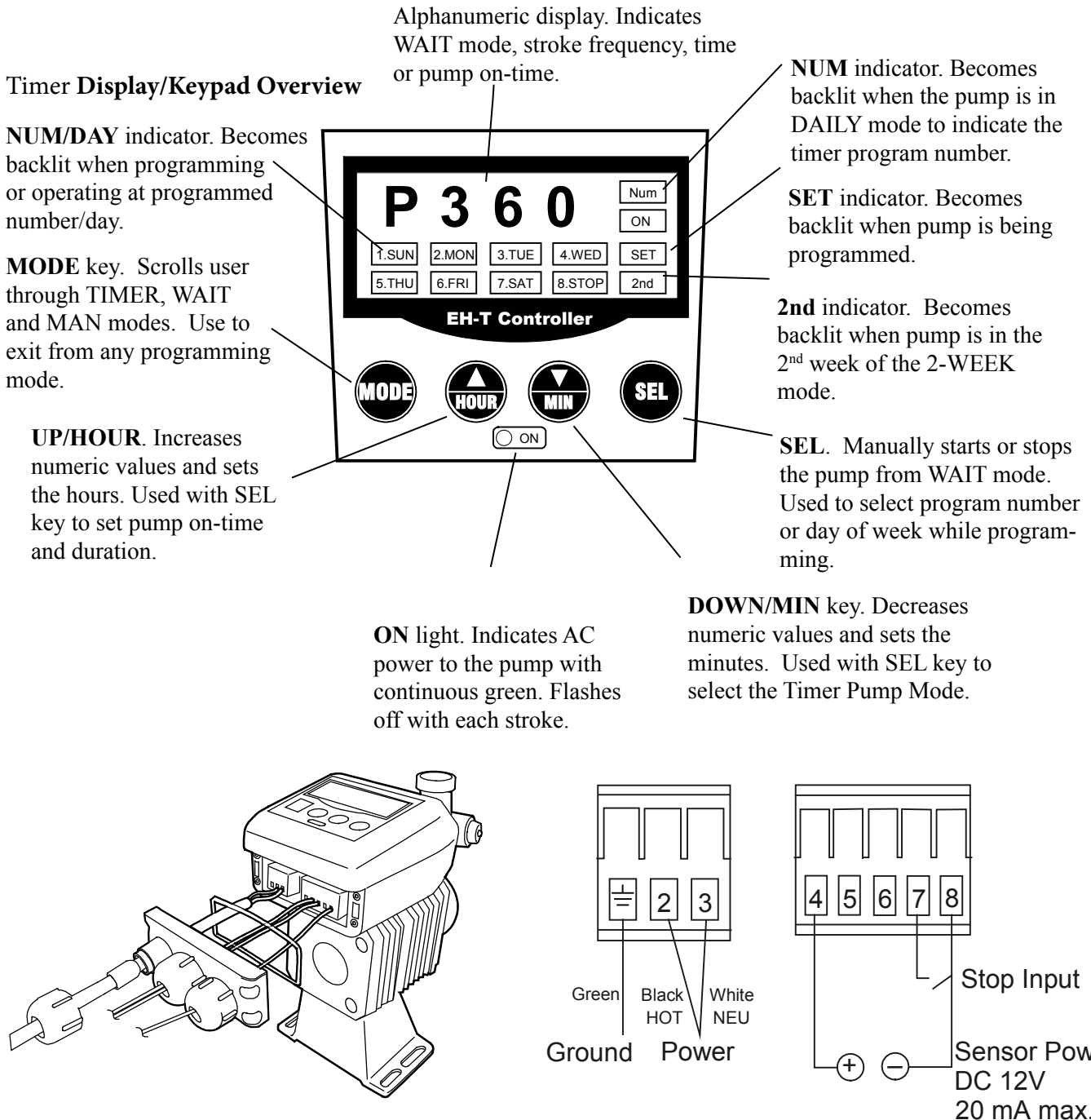

Figure 8

EZ-T Quick Reference Guide

(MODE) Mode Key

(SEL) Select Key

FROM:	PRESS:	TO:
TIMER RUN MENU	(MODE)	Move to WAIT menu
WAIT MENU	(MODE)	Move to MANUAL menu
	(SEL) (Hold for 3 seconds)	Move to TIME / DATE setting menu
	(SEL) + (▲) HOUR	Move to TIMER programming menu
	(SEL) + (▼) MIN	Move to TIMER MODE selection menu
MANUAL MENU	(MODE)	Move to TIMER RUN mode (shows TIME)
	(SEL)	Starts and stops manual operation
	(▼) MIN OR (▲) HOUR	Changes pump frequency (1 to 360 SPM)
TIME / DATE MENU (24 Hour Clock)	(▲) HOUR	Sets the Hour (incrementing only)
	(▼) MIN	Sets the Minutes (incrementing only)
	(SEL)	Selects the Day of the week
	(MODE)	Exits back to WAIT menu
TIMER MODE MENU	(▲) HOUR OR (▼) MIN	Scrolls between DAILY, WEEK or 2-WEEK Timer modes
	(MODE)	Exits back to WAIT menu
TIMER PROGRAMMING MENU	(▲) HOUR	Sets the Hour / Sets On-Time Minutes
	(▼) MIN	Sets the Minutes / Sets On-Time Minutes
	(SEL)	Scrolls through the week days / program #
	(MODE)	Exits back to WAIT menu

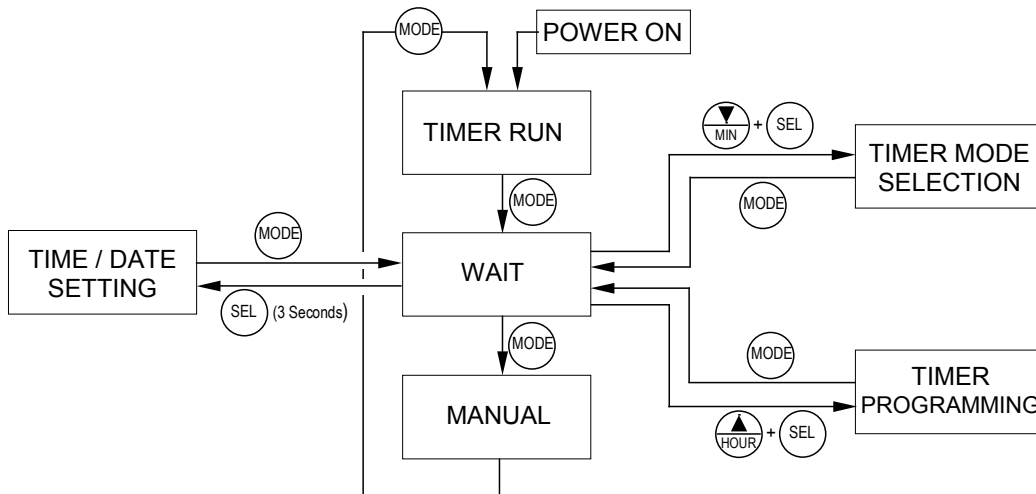

Programming and Timer Use



CAUTION! Before use, check the time and date. Set to the local time and date before programming. Incorrect time/date can result in incorrect operation.

1. Manual Operation

From the WAIT menu, pressing the MODE key will enter the manual mode. Pressing SEL will toggle the pump on and off manually. The speed can be changed with the UP and DOWN arrows both running and waiting. NOTE: The pump speed set in this menu will be the speed that the pump will run during timed operations.

2. Time/Date Setting

From the WAIT menu, holding the SEL key down for 3 seconds will enter into the Time/Date SET menu. Using the HOUR and MIN keys, the time can be set using a 24-hour clock. The SEL key will cycle through the days of the week.

Once the correct time and day of the week are set, pressing the MODE key will go back to the WAIT menu.

3. Timer Mode Selection

Pressing the MIN and SEL keys at the same time will bring up the Mode Selection menu. This menu is where the Timer module is set to control in daily, weekly, or in 2-week modes. Use the UP and DOWN keys to cycle through the three options and MODE to get back to the WAIT menu. Daily mode allows a max of up to 8 timed operations repeated every day. Weekly and 2-week modes allow a max of one timed operation per day.

4. Timer Operation Programming

Pressing the HOUR and SEL keys at the same time will bring up the Timer Programming menu. This menu is where the individual operations are set – both start time and run time.

DAILY MODE:

Initially, the 1-SUN and NUM will both be backlit. NUM is backlit to signal that the number backlit is used – i.e. program 1 in this case. Using the HOUR and MIN keys, the time for the first program can be set (24-hour clock). Pressing the SEL key will change the menu to program the on-time to run the pump (initially shows “ 0M”). Use the UP and DOWN keys to program the # of minutes for the pump to run. Pressing SEL again will then move to program the second program and the backlight will move from 1-SUN to 2-MON. The clock and on-time settings are set in the same manner. Pressing MODE will go back to the WAIT menu.

WEEKLY MODE:

Initially, the 1-SUN will be backlit signifying that Sunday is being programmed. If a program is desired for Sunday, use the HOUR and MIN keys to set the time of the program. If no program is desired for Sunday, pressing the SEL key will scroll through each day's two programmed settings – the time to start and the run time. Pressing MODE will go back to the WAIT menu at any point in the programming.

2-WEEK MODE:

Two week mode is similar and set just as the weekly mode, only after the first 7-SAT is programmed or passed by and 1-SUN is again backlit, the “2nd” will also become backlit showing that the day is in the 2nd week. All programming functions are the same and SEL will scroll through each setting. Pressing MODE will go back to the WAIT menu at any point in the programming.

From the WAIT mode, pressing MODE will move to the MANUAL menu. Check to make sure that the pump speed is set at the rate desired during the timed operations. If not, use the UP and DOWN keys to change the pump speed.

Pressing MODE again will display the current time and date. The pump is now operating in the TIMER mode and will come on at the next programmed timer operation.

3.3 Calibration

If exact output calibration is required, first prime and adjust the pump as above. Then connect a calibration column to the suction side of the pump. Turn the pump on for one minute and read the amount of liquid pumped from the column. Adjust the frequency up or down as necessary and check the output again. When the desired output is reached, disconnect the calibration column and reconnect the suction tubing. (See Figure 9) Calibration must be performed with application equivalent back pressure for accurate results. Published flow rates are based on maximum pressures. Lower back pressures may result in slightly higher pump flow rates.

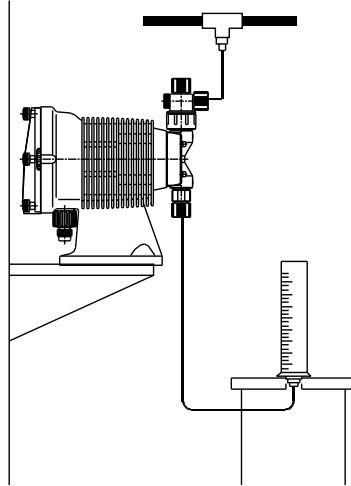

Figure 9 Calibration

3.4 STOP Function

Additionally, EZ pumps with a Timer Module can be controlled in start-stop mode. In this mode, AC power is applied continuously and pump operation is stopped by completing the circuit between the positive 'stop' and common terminals inside the T Control Module: 7 (positive) and 8 (common). A switch or solid state device capable of switching 5VDC at 2 mA should be used. Switch closed = pump stopped, switch open = pump running at the speed determined by the frequency setting. This feature eliminates the need for a high voltage, high current AC relay to start and stop the pump. (See Figure 8)

3.5 AC Power Interruption

If AC power is interrupted, the pump will power up as shown below:

State preceding power OFF	State following power ON
WAIT	WAIT
Running in Manual Operation	Running in Manual Operation
Running in Timer Operation	Running in Timer Operation
Setting Time	WAIT
Programming Timer Set points	WAIT

3.6 Auto Degassing Valve Operation

The Auto Degassing Valve (ADV) is an option on select EZ pumps and is added under the standard Manual Air Vent Valve when ordered. It is used primarily in applications where gassing is a problem and pumps can lose prime.

Unlike the Manual Air Vent Valve, the Auto Degassing Valve constantly bleeds a controlled amount of volume out of the “Air” vent. Therefore, the “Air” vent should always be plumbed back to the source tank. During priming, the access knob does not have to be loosened as with a manual air vent valve as pressure is relieved through the vent. The check valve assembly in the ADV uses a bottom seat to ensure that air is not introduced into the discharge media and utilizes a second top seat that allows air to be quickly purged but limits the amount of liquid returned to the tank. Moving the pump check valves above the ADV maintains back pressure within the pump discharge, but allows the pump head to bleed, helping to speed the purging of air and auto re-priming the pump.

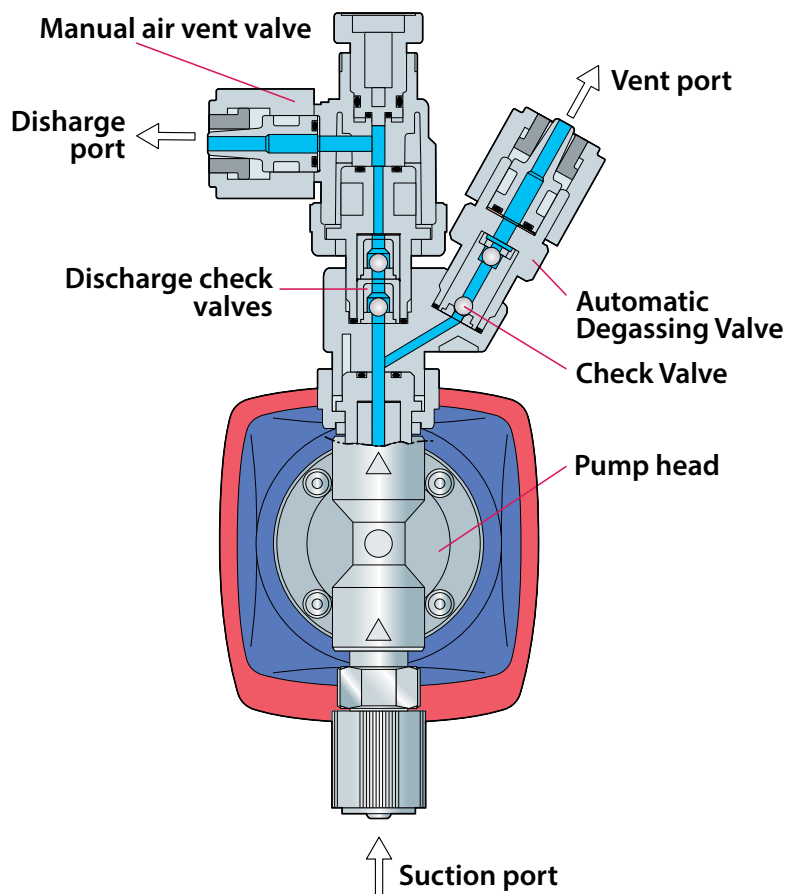

AAVV – Cross Sectional View

3.7 MultiFunction Valve Operation

The MultiFunction Valve is optional on select E-Series pumps and replaces the standard Manual Air Vent Valve when ordered. It integrates the air venting/bleeding functions with a back pressure, anti-siphon, and pressure relief valve. For more detailed specifications of the MultiFunction Valve, see its separate instruction sheet at walchem.com.

Air Vent / Bleed Function

1. Open the air vent by turning the relief valve knob 90 degrees to the “AV” position.
2. Operate the pump until all of the air is purged and only liquid is discharged from the air vent drain.
3. Turn the relief valve knob back 90 degrees to the “RV” position to set pressure relief.

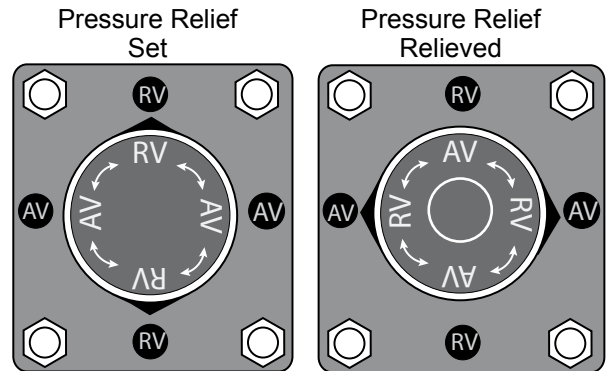
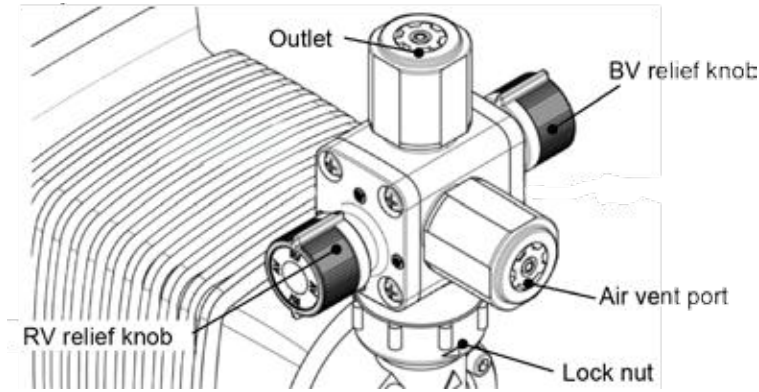

Pressure Relief

1. In the “RV” position, the diaphragm under the relief valve knob provides a safety relief if the discharge line pressure gets too high.

Line Pressure Relief

1. By rotating both the Relief valve knob to “AV” and the back pressure valve knob to “PF”, both the discharge line and the pump head pressures are released out the air vent for full line pressure release.

Back Pressure / Anti-Siphon Valve

1. A spring-loaded diaphragm under the back pressure knob automatically adds approximately 36PSI (15 PSI for low pressure versions) of back pressure to the discharge side of the pump when the knob is set to the “BP” position.
2. The diaphragm also prevents siphoning of chemical through the pump.

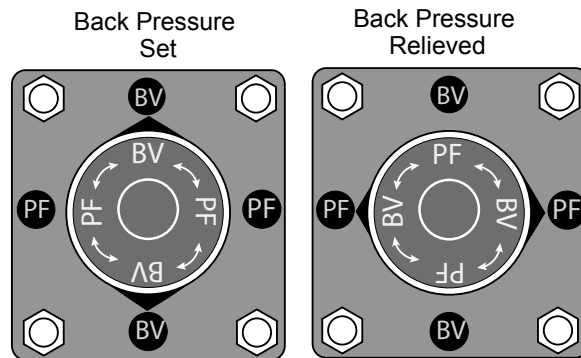

CAUTION: Confirm that liquid is discharged from the air vent drain. If the liquid is not discharged, the pressure may not be released. If this is the case, repeat the Pressure Relief procedure.

4.0 MAINTENANCE



CAUTION! Before working on the pump, disconnect the power cord, depressurize the discharge tubing and drain or flush any residual liquid from the pump head and valves. Always wear protective gear when working around chemicals.

4.1 Diaphragm Replacement

Disconnect AC power to the pump and disconnect the suction tubing, discharge tubing, and air vent tubing. Remove the four head bolts with a 4mm hex wrench. Unscrew the diaphragm and remove its retainer (small disk behind the diaphragm). **CAUTION: There may be small brass spacers between the retainer and the armature shaft. These spacers need to be reused when replacing the diaphragm.** Install the new retainer and diaphragm on the shaft. Turn the diaphragm clockwise until it bottoms on the shaft. Use caution when handling the diaphragm – the PTFE surface can be damaged by tools, nails or any sharp objects. Replace the pump head and tighten the head bolts to a torque of 19 lb-in (2.16 N-m).

4.2 Valve Replacement

Remove the suction and discharge tubing making sure discharge side has been depressurized. Remove the suction fitting, two valve cartridges, o-ring and gasket(s). Install the new o-ring, gasket(s) and valve cartridges. Be sure both valve seats are in the same orientation. Refer to Figure below. Tighten the suction fitting. Similarly remove and replace the discharge valve cartridges, o-ring and gasket(s). For a more detailed drawing, refer to the Section 6.0.



CAUTION: There are many small parts in the liquid end. These parts must be installed correctly for proper operation of the pump.

4.3 Tubing

Check ends of tubing for splits, cracks, or thin spots. Examine the full length of tubing for damage due to chafing, abrasion, stress cracks, excessive temperature or exposure to ultraviolet light (direct sunlight or mercury vapor lamps). If any signs of deterioration exist, replace the entire length of tubing. It is a good idea to replace discharge tubing on a regular preventive maintenance schedule every 12 months.

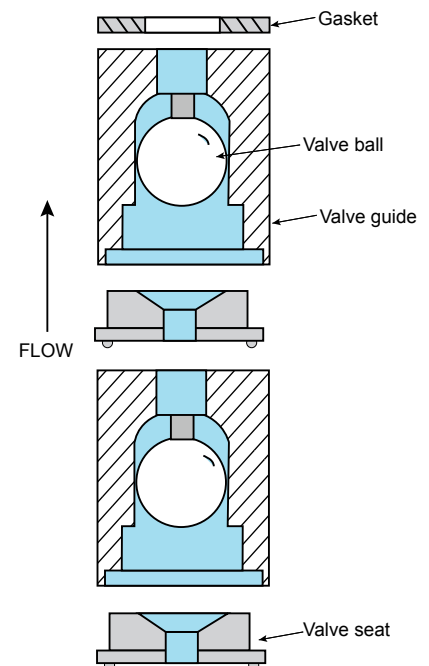

5.0 EXPLODED VIEW & PARTS GUIDE

PVC/GFRPP Liquid End Exploded View

For EZ pump model sizes 11-36

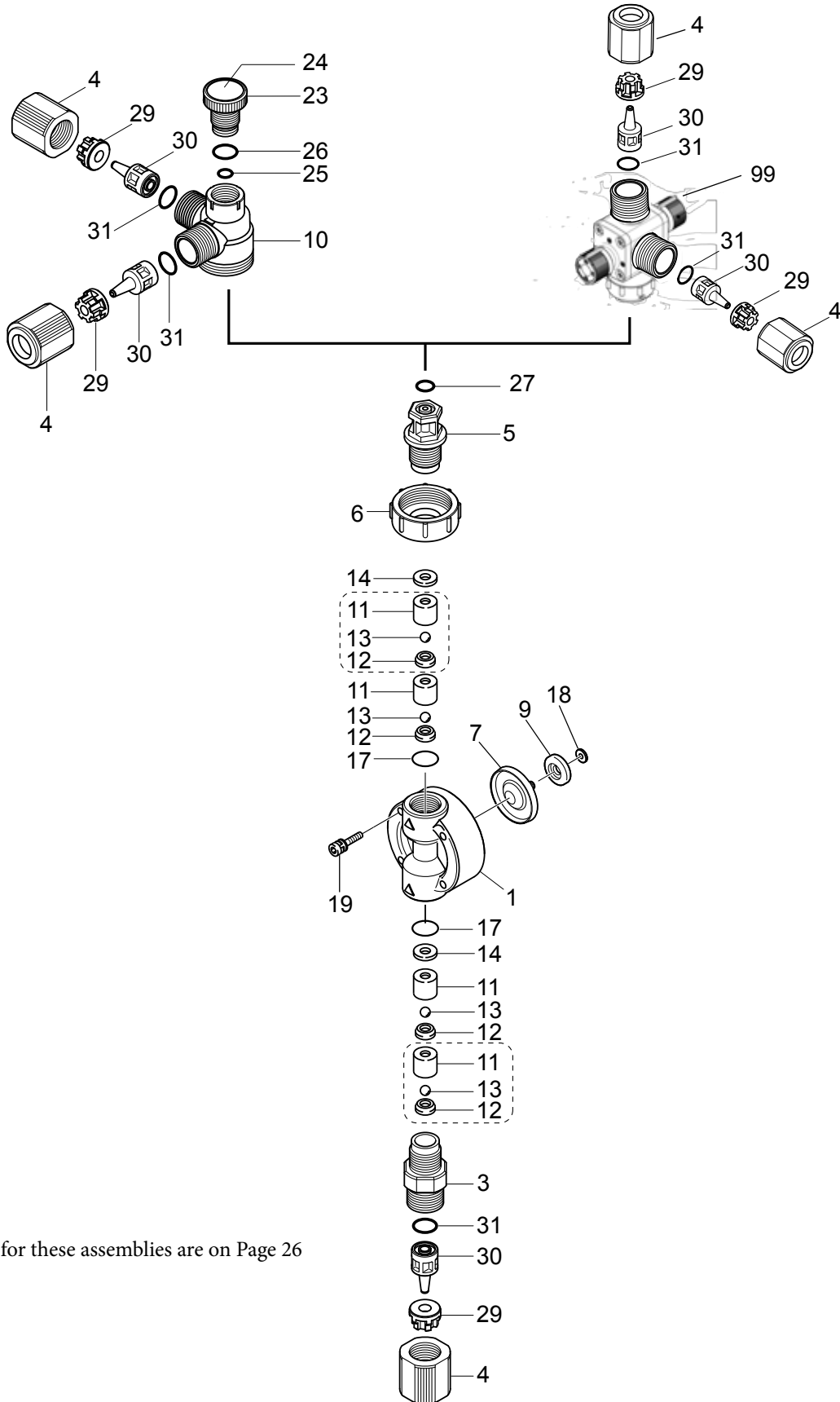

Part numbers for these assemblies are on Page 26

PVC/GFRPP Sizes 11-36 Liquid End Components

Item	Part#	Description	Qty	Material	Size	Liquid End Material
1	EH1947	Pump Head	1	PVC	B11	VC, VE, VF
	EH1948		1	PVC	B16	VC, VE, VF
	EH1949		1	PVC	B21	VC, VE, VF
	EH1950		1	PVC	C16	VC, VE, VF
	EH1951		1	PVC	C21	VC, VE, VF,
	EH1952		1	PVC	B36	VC, VE, VF
	EH1960		1	PVC	C31	VC, VE, VF
	EH1953		1	PVC	C36	VC, VE, VF
	EH1954		1	GFRPP	B11	PC, PA, PE
	EH1955		1	GFRPP	B16	PC, PA, PE
	EH1956		1	GFRPP	B21	PC, PA, PE
	EH1957		1	GFRPP	C16	PC, PA, PE
	EH1958		1	GFRPP	C21	PC, PA, PE
	EH1959		1	GFRPP	B31	PC, PA, PE
	EH1961		1	GFRPP	C31	PC, PA, PE
	EH1962		1	GFRPP	C36	PC, PA, PE
3	EH2328	Housing, Valve (Suction)	1	PVC	B11,16,21 / C16,21	VC, VE, VF
	EH2329		1	PVC	B31 / C31,36	VC, VE, VF
	EH2349		1	GFRPP	B11,16,21 / C16,21	PC, PE, PA
	EH2350		1	GFRPP	B31 / C31,36	PC, PE, PA
	EH2330		Coupling Nut	3	PVC	B11,16,21,31 / C16,21,31,36
EH2351	3	GFRPP		B11,16,21,31 / C16,21,31,36	PC, PE, PA	
5	EH2331	Fitting, MAVV	1	PVC	B11,16,21 /C16,21	VC, VE, VF
	EH2332		1	PVC	B31 / C31,36	VC, VE, VF
	EH2352		1	GFRPP	B11,16,21 /C16,21	PC, PE, PA
	EH2353		1	GFRPP	B31 / C31,36	PC, PA, PE
	EH2333		Lock Nut, MAVV	1	PVC	B11,16,21,31 / C16,21,31,36
EH2354	1	GFRPP		B11,16,21,31 / C16,21,31,36	PC, PE, PA	
*7	EH1971	Diaphragm	1	PTFE+EPDM	B11	ALL
	EH1972		1	PTFE+EPDM	B16 / C16	ALL
	EH1973		1	PTFE+EPDM	B21 / C21	ALL
	EH1974		1	PTFE+EPDM	B31 / C31	ALL
	EH1975		1	PTFE+EPDM	C36	ALL
	EH0059		Retainer	1	PPS+GF	B11
EH0083	1	PPS+GF		B16 / C16	ALL	
EH0067	1	PPS+GF		B21 / C21	ALL	
EH0087	1	PPS+GF		B31 / C31	ALL	
EH0158	1	PPS+GF		C36	ALL	
10	EH2334	Body, MAVV	1	PVC	B11,16,21,31 / C16,21,31,36	VC, VE, VF
	EH2355		1	GFRPP	B11,16,21,31 / C16,21,31,36	PC, PE, PA
*11	EH0060	Guide, Valve	4	PVC	B11	VC, VE, VF
	EH0068		4	PVC	B16,21 /C16,21	VC, VE, VF
	EH0118		4	PVC	B31 / C31,36	VC, VE, VF
	EH0318		4	GFRPP	B11	PC, PE, PA
	EH1534		4	GFRPP	B16,21 /C16,21	PC, PE, PA
	EH0332		4	GFRPP	B31 / C31,36	PC, PE, PA

PVC/GFRPP Sizes 11-36 Liquid End Components (continued)

Item	Part#	Description	Qty	Material	Size	Liquid End Material
*12	EH0061	Seat, Valve	4	FKMA	B11	VC, PC
	EH0069		4	FKMA	B16,21 / C16,21	VC, PC
	EH0119		4	FKMA	B31 / C31,36	VC, PC
	EH0048		4	EPDM	B11	VE, VF, PE
	EH0071		4	EPDM	B16,21 / C16,21	VE, VF, PE
	EH0125		4	EPDM	B31 / C31,36	VE, VF, PE
	EH2415		4	PCTFE	B11	PA
	EH2416		4	PCTFE	B16, 21/ C16, 21	PA
	EH0593		4	PCTFE	B31 / C31, 36	PA
	*13	EH0025	Ball, Valve	4	CE	B11
EH0084			4	CE	B16,21 / C16,21	VC, VE, PC, PE, PA
EH0120			4	CE	B31 / C31,36	VC, VE, PC, PE, PA
E00063			4	PTFE	B11	VF
E00064			4	PTFE	B16, 21 / C16, 21	VF
E00062			4	PTFE	B31 / C31, 36	VF
*14	EH0026	Gasket, Valve	2 (6)	PTFE	B11,16, 21 / C16,21	VC, VE, VF (PA)
	EH0121		2 (6)	PTFE	B31 / C31,36	VC, VE, VF, PC, PE (PA)
	EH2178		2	PTFE	B11	PC, PE
	EH0580		2	PTFE	B16, 21 / C16,21	PC, PE
*17	EH0027	O-Ring, S14	2	FKMA	B11,16, 21 / C16,21	VC, PC
	EH0050		2	EPDM	B11,16, 21 / C16,21	VE, VF, PE
	E00179		2	AFLAS™	B11,16, 21 / C16,21	PA
	EH0122	O-Ring, P16	2	FKMA	B31 / C31,36	VC, PC
	EH0127		2	EPDM	B31 / C31,36	VE, VF, PE
	E00201		2	AFLAS™	B31 / C31,36	PA
19	EH1986	Bolt, Hex Soc. w/washers	4	M4x35 316SS	C16,21,31	ALL
	EH1987		4	M4x40 316SS	B11,16,21,31	ALL
	EH1988		4	M5x35 316SS	C36	ALL
23	EH0299	Knob, MAVV	1	PVC	B11,16,21,31 / C16,21,31,36	VC, VE, VF
	EH0321		1	GFRPP	B11,16,21,31 / C16,21,31,36	PC, PE, PA
24	EH1314	Label, MAVV Knob	1		B11,16,21,31 / C16,21,31,36	ALL
*25	EH0300	O-Ring, P4	1	FKMA	B11,16,21,31 / C16,21,31,36	VC, PC
	EH0301		1	EPDM	B11,16,21,31 / C16,21,31,36	VE, VF, PE
	E00176		1	AFLAS™	B11,16,21,31 / C16,21,31,36	PA
*26	EH0302	O-Ring, P10A	1	FKMA	B11,16,21,31 / C16,21,31,36	VC, PC
	EH0303		1	EPDM	B11,16,21,31 / C16,21,31,36	VE, VF, PE
	E00174		1	AFLAS™	B11,16,21,31 / C16,21,31,36	PA
*27	EH2335	O-Ring, P10	1	FKMA	B11,16,21,31 / C16,21,31,36	VC, PC
	EH2336		1	EPDM	B11,16,21,31 / C16,21,31,36	VE, VF, PE
	E00173		1	AFLAS™	B11,16,21,31 / C16,21,31,36	PA
*29	EH2337	Clamp Ring, 3/8" OD	3	PPS+GF	B11,16,21 / C16,21	ALL
	EH2338	Clamp Ring, 1/2" OD	3	PPS+GF	B31 / C31,36	ALL
*30	EH2339	Adapter, Tubing, 3/8"OD	3	PVC	B11,16,21 / C16,21	VC, VE, VF
	EH2356		3	GFRPP	B11,16,21 / C16,21	PC, PE, PA
	EH2340	Adapter, Tubing, 1/2"OD	3	PVC	B31 / C31,36	VC, VE, VF
	EH2357		3	GFRPP	B31 / C31,36	PC, PA, PE
*31	EH2341	O-Ring, P9	3	FKMA	B11,16,21,31 / C16,21,31,36	VC, PC
	EH1585		3	EPDM	B11,16,21,31 / C16,21,31,36	VE, VF, PE
	E00178		3	AFLAS™	B11,16,21,31 / C16,21,31,36	PA
18	-----	Brass Spacers	--	Brass	Drive Specific. Reuse with Dia. change	ALL
99	MFV-HTC-7	Multi-Function Valve	1	PVDF/PTFE/AFLAS	B11,16 / C16,21	xxM
	MFV-MTC-7		1	PVDF/PTFE/AFLAS	B21	xxM
	MFV-MTC-8		1	PVDF/PTFE/AFLAS	C31	xxM
	MFV-LTC-8		1	PVDF/PTFE/AFLAS	B31 / C36	xxM

* Parts Included in the Spart Parts Kits

VCA-VEA Liquid End Exploded View For EZ pump model sizes 11 thru 21

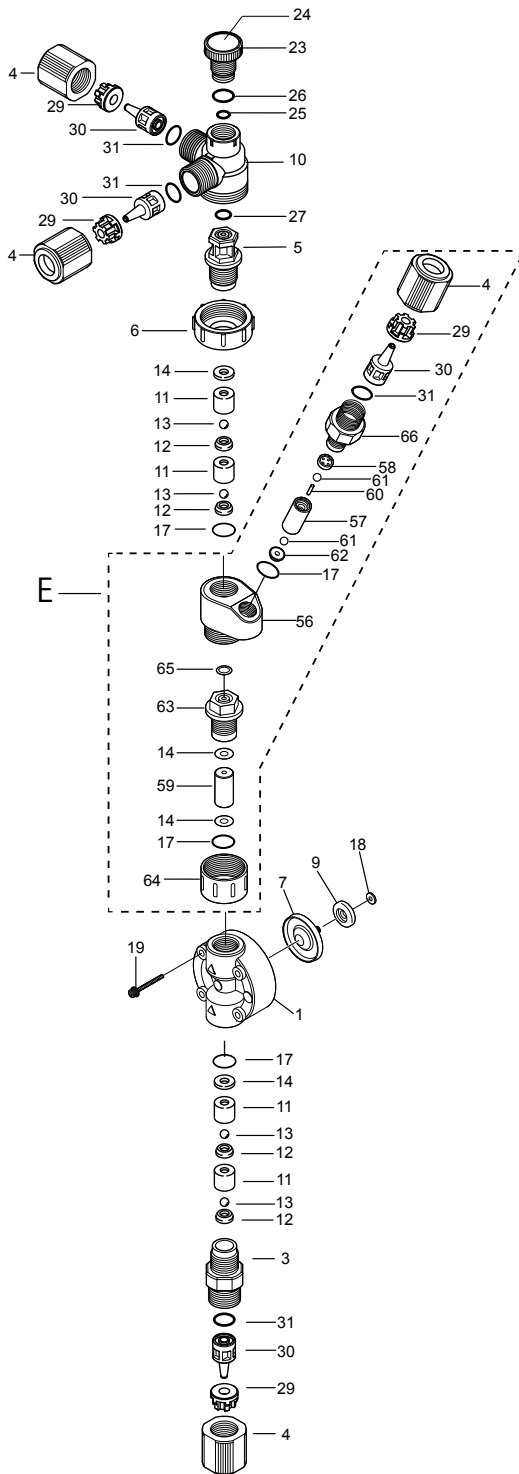

E Auto Degassing Valve
Part Numbers for these assemblies are on
Page 26

Item	Part#	Description	Qty	Material	Size	Liquid End Material
1	EH1947	Pump Head	1	PVC	B11	VCA,VEA
	EH1948		1	PVC	B16	VCA,VEA
	EH1949		1	PVC	B21	VCA,VEA
	EH1950		1	PVC	C16	VCA,VEA
	EH1951		1	PVC	C21	VCA,VEA
3	EH2328	Housing, Valve (Suction)	1	PVC	B11,16,21 / C16,21	VCA,VEA
4	EH2330	Coupling Nut	4	PVC	B11,16,21 / C16,21	VCA,VEA
5	EH2331	Fitting, MAVV	1	PVC	B11,16,21 / C16,21	VCA,VEA
6	EH2333	Lock Nut, MAVV	1	PVC	B11,16,21 / C16,21	VCA,VEA
*7	EH1971	Diaphragm	1	PTFE+EPDM	B11	VCA,VEA
	EH1972		1	PTFE+EPDM	B16 / C16	VCA,VEA
	EH1973		1	PTFE+EPDM	B21 / C21	VCA,VEA
*9	EH0059	Retainer	1	PPS+GF	B11	VCA,VEA
	EH0083		1	PPS+GF	B16 / C16	VCA,VEA
	EH0067		1	PPS+GF	B21 / C21	VCA,VEA
10	EH2334	Body, MAVV	1	PVC	B11,16,21 / C16,21	VCA,VEA
*11	EH0060	Guide, Valve	4	PVC	B11 /	VCA,VEA
	EH0068		4	PVC	B16,21 /C16,21	VCA,VEA
*12	EH0061	Seat, Valve	4	FKMA	B11	VCA
	EH0069		4	FKMA	B16,21 / C16,21	VCA
	EH0048		4	EPDM	B11	VEA
	EH0071		4	EPDM	B16,21 / C16,21	VEA
*13	EH0025	Ball, Valve	4	CE	B11	VCA,VEA
	EH0084		4	CE	B16,21 / C16,21	VCA,VEA
*14	EH0026	Gasket, Valve	4	PTFE	B11,16,21 / C16,21	VCA,VEA
*17	EH0027	O-Ring, S14	4	FKMA	B11,16,21 / C16,21	VCA
	EH0050		4	EPDM	B11,16,21 / C16,21	VEA
19	EH1986	Bolt, Hex Soc. w/washers	4	M4x35 316SS	C16,21	VCA,VEA
	EH1987		4	M4x40 316SS	B11,16,21	VCA,VEA
23	EH0299	Knob, MAVV	1	PVC	B11,16,21 / C16,21	VCA,VEA
24	EH1314	Label, MAVV Knob	1		B11,16,21 / C16,21	ALL
*25	EH0300	O-Ring, P4	1	FKMA	B11,16,21 / C16,21	VCA
	EH0301		1	EPDM	B11,16,21 / C16,21	VEA
*26	EH0302	O-Ring, P10A	1	FKMA	B11,16,21 / C16,21	VCA
	EH0303		1	EPDM	B11,16,21 / C16,21	VEA
*27	EH2335	O-Ring, P10	1	FKMA	B11,16,21 / C16,21	VCA
	EH2336		1	EPDM	B11,16,21 / C16,21	VEA
*29	EH2337	Clamp Ring, 3/8" OD	4	PPS+GF	B11,16,21 / C16,21	VCA,VEA
*30	EH2339	Adapter,Tubing, 3/8"OD	4	PVC	B11,16,21 / C16,21	VCA,VEA
*31	EH2341	O-Ring, P9	3	FKMA	B11,16,21 / C16,21	VCA
	EH1585		3	EPDM	B11,16,21 / C16,21	VEA
56	EH1682	Body, Auto Degassing Valve	1	PVC	B11,16,21 / C16,21	VCA,VEA
*57	EH1684	Guide, Separation Pin, ADV	1	PVC	B11,16,21 / C16,21	VCA,VEA
*58	EH1685	Top Disc, Guide, ADV	1	PVC	B11,16,21 / C16,21	VCA,VEA
59	EH1683	Spacer, Valve Guides, ADV	1	PVC	B11,16,21 / C16,21	VCA,VEA
*60	EH1686	Separation Pin, ADV	1	Titanium	B11,16,21 / C16,21	VCA
	EH1687		1	HC276	B11,16,21 / C16,21	VEA, VCA-H
*61	EH0025	Ball, Valve, ADV	2	CE	B11,16,21 / C16,21	VCA,VEA
*62	EH0061	Seat, Valve, ADV	1	FKMA	B11,16,21 / C16,21	VCA
	EH0048		1	EPDM	B11,16,21 / C16,21	VEA
63	EH0294	Fitting, ADV	1	PVC	B11,16,21 / C16,21	VCA,VEA
64	EH0295	Lock Nut, ADV	1	PVC	B11,16,21 / C16,21	VCA,VEA
*65	EH0304	O-Ring, P7	1	FKMA	B11,16,21 / C16,21	VCA
	EH0305		1	EPDM	B11,16,21 / C16,21	VEA
66	EWN0157	Housing, Valve, ADV	1	PVC	B11,16,21 / C16,21	VCA,VEA
18	-----	Brass Spacers	--	Brass	Drive Specific. Reuse with Dia. change	ALL

*Parts Included in the Spart Parts Kits

TC/TA Liquid End Exploded View For EZ Pump Models 11-36

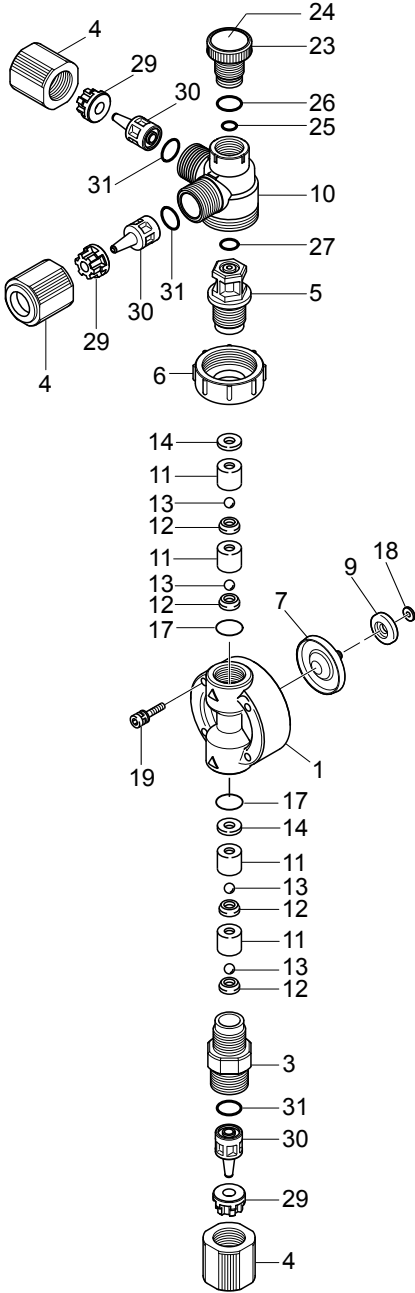

Part numbers for these assemblies are on Page 26

*** Parts Included in the Spare Parts Kits**

Item	Part#	Description	Qty	Material	Size	Liquid End Material
1	EH2407	Pump Head	1	PVDF	B11	TC, TA
	EH2408		1	PVDF	B16	TC, TA
	EH2409		1	PVDF	B21	TC, TA
	EH1969		1	PVDF	B31	TC, TA
	EH2411		1	PVDF	C16	TC, TA
	EH2412		1	PVDF	C21	TC, TA
	EH1966		1	PVDF	C31	TC, TA
3	EH1967		1	PVDF	C36	TC, TA
	EH2359	Housing, Valve (Suction)	1	PVDF	B11,16,21 / C16,21	TC, TA
	EH2360		1	PVDF	B31 / C31,36	TC, TA
4	EH2363	Coupling Nut	3	PVDF	B11,16,21 / C16,21,31,36	TC, TA
5	EH2364	Fitting, MAVV	1	PVDF	B11,16,21 / C16,21	TC, TA
	EH2365		1	PVDF	B31 / C31,36	TC, TA
6	EH2366	Lock Nut, MAVV	1	PVDF	B11,16,21,31 / C16,21,31,36	TC, TA
*7	EH1971	Diaphragm	1	PTFE+EPDM	B11	ALL
	EH1972		1	PTFE+EPDM	B16 / C16	ALL
	EH1973		1	PTFE+EPDM	B21 / C21	ALL
	EH1974		1	PTFE+EPDM	B31 / C31	ALL
	EH1975		1	PTFE+EPDM	C36	ALL
*9	EH0059	Retainer	1	PPS+GF	B11	ALL
	EH0083		1	PPS+GF	B16 / C16	ALL
	EH0067		1	PPS+GF	B21 / C21	ALL
	EH0087		1	PPS+GF	B31 / C31	ALL
	EH0158		1	PPS+GF	C36	ALL
10	EH2367	Body, MAVV	1	PVDF	B11,16,21 / C16,21,31,36	TC, TA
*11	EH2413	Guide, Valve	4	PVDF	B11	TC, TA
	EH2414		4	PVDF	B16,21 / C16,21	TC, TA
	EH2368		4	PVDF	B31 / C31,36	TC, TA
	EH0061	Seat, Valve	4	FKMA	B11	TC
	EH0069		4	FKMA	B16,21 / C16,21	TC
	EH0119		4	FKMA	B31 / C31,36	TC
	EH2415		4	PCTFE	B11	TA
	EH2416		4	PCTFE	B16, 21/ C16, 21	TA
	EH0593		4	PCTFE	B31 / C31, 36	TA
*13	EH0025	Ball, Valve	4	CE	B11	TC, TA
	EH0084		4	CE	B16,21 / C16,21	TC, TA
	EH0120		4	CE	B31 / C31,36	TC, TA
*14	EH0342	Gasket, Valve	2 (6)	PTFE	B11,16,21 / C16,21	TC (TA)
	EH0354		2 (6)	PTFE	B31 / C31,36	TC (TA)
*17	EH0027	O-Ring, S14	2	FKMA	B11,16,21 / C16,21	TC
	E00179		2	AFLAS™	B11,16,21 / C16,21	TA
	EH0122	O-Ring, P16	2	FKMA	B31 / C31,36	TC
	E00201		2	AFLAS™	B31 / C31,36	TA
19	EH1986	Bolt, Hex Soc. w/washers	4	M4x35 316SS	B11,16,21/ C16,21,31	ALL
	EH1987		4	M4x40 316SS	B31	ALL
	EH1988		4	M5x35 316SS	C36	ALL
23	EH1049	Knob, MAVV	1	PVDF	B11,16,21,31 / C16,21,31,36	TC, TA
24	EH1314	Label, MAVV Knob	1		B11,16,21,31 / C16,21,31,36	ALL
*25	EH0300	O-Ring, P4	1	FKMA	B11,16,21,31 / C16,21,31,36	TC
	E00176		1	AFLAS™	B11,16,21,31 / C16,21,31,36	TA
*26	EH0302	O-Ring, P10A	1	FKMA	B11,16,21,31 / C16,21,31,36	TC
	E00174		1	AFLAS™	B11,16,21,31 / C16,21,31,36	TA
*27	EH2335	O-Ring, P10	1	FKMA	B11,16,21,31 / C16,21,31,36	TC
	E00173		1	AFLAS™	B11,16,21,31 / C16,21,31,36	TA
*29	EH2337	Clamp Ring, 3/8" OD	3	PPS+GF	B11,16,21 / C16,21	TC, TA
	EH2338	Clamp Ring, 1/2" OD	3	PPS+GF	B31 / C31,36	TC, TA
*30	EH2369	Adapter, Tubing, 3/8"OD	3	PVDF	B11,16,21 / C16,21	TC, TA
	EH2370	Adapter, Tubing, 1/2"OD	3	PVDF	B31 / C31,36	TC, TA
*31	EH2341	O-Ring, P9	3	FKMA	B11,16,21,31 / C16,21,31,36	TC
	E00178		3	AFLAS™	B11,16,21,31 / C16,21,31,36	TA
18	-----	Brass Spacers	--	Brass	Drive Specific. Reuse with Dia. change	ALL

FC Liquid End Exploded View For EZ Pump Models 11-36

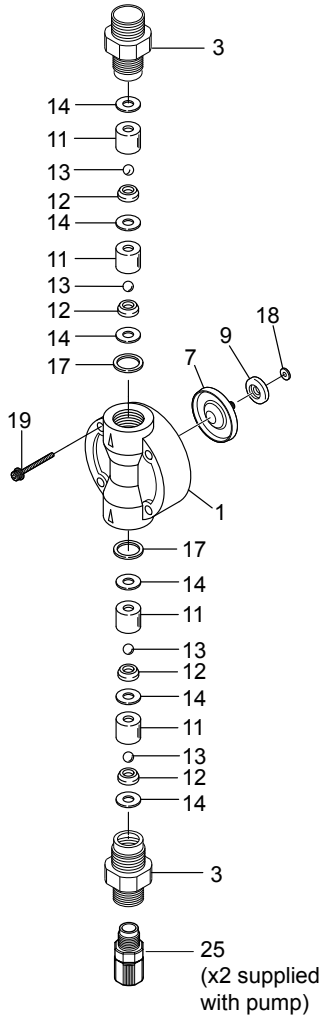

Item	Part#	Description	Qty	Material	Size	Liquid End Material
1	EH2407	Pump Head	1	PVDF	B11	FC
	EH2408		1	PVDF	B16	FC
	EH2409		1	PVDF	B21	FC
	EH1969		1	PVDF	B31	FC
	EH2411		1	PVDF	C16	FC
	EH2412		1	PVDF	C21	FC
	EH1966		1	PVDF	C31	FC
	EH1967		1	PVDF	C36	FC
	3	EH2361	Housing, Valve	2	PVDF	B11,16,21 / C16,21
EH2362			2	PVDF	B31 / C31,36	FC
*7	EH1971	Diaphragm	1	PTFE+EPDM	B11	FC
	EH1972		1	PTFE+EPDM	B16 / C16	FC
	EH1973		1	PTFE+EPDM	B21 / C21	FC
	EH1974		1	PTFE+EPDM	B31 / C31	FC
	EH1975		1	PTFE+EPDM	C36	FC
	*9	EH0059	Retainer	1	PPS+GF	B11
EH0083			1	PPS+GF	B16 / C16	FC
EH0067			1	PPS+GF	B21 / C21	FC
EH0087			1	PPS+GF	B31 / C31	FC
EH0158			1	PPS+GF	C36	FC
*11	EH2413	Guide, Valve	4	PVDF	B11	FC
	EH2414		4	PVDF	B16,21 / C16,21	FC
	EH0352		4	PVDF	B31 / C31,36	FC
*12	EH2415	Seat, Valve	4	PCTFE	B11	FC
	EH2416		4	PCTFE	B16,21 / C16,21	FC
	EH1722		4	PCTFE	B31 / C31,36	FC
*13	EH0025	Ball, Valve	4	CE	B11	FC
	EH0084		4	CE	B16,21 / C16,21	FC
	EH0120		4	CE	B31 / C31,36	FC
*14	EH0354	Gasket, Valve	6	PTFE	B31 / C31,36	FC
	EH0342		6	PTFE	B11,16,21 / C16,21	FC
*17	EH0591	Gasket, Valve Housing	2	PTFE	B11,16,21 / C16,21	FC
	EH0613		2	PTFE	B31 / C31,36	FC
19	EH1986	Bolt, Hex Soc. w/washers	4	M4x35 316SS	B11,16,21/ C16,21,31	FC
	EH1987		4	M4x40 316SS	B31	FC
	EH1988		4	M5x35 316SS	C36	FC
25	E00260	Fitting, 3/8"Tube x 1/4"MPT	2	PVDF	B11,16,21 / C16,21	FC
	E00261	Fitting, 1/2"Tube x 1/4"MPT	2	PVDF	B31 / C31,36	FC
18	-----	Brass Spacers	--	Brass	Drive Specific. Reuse with Dia. change	ALL

*** Parts Included in the Spart Parts Kits**

Stainless Steel (SH-N) Liquid End Exploded View For EZ Pump Models 11-36

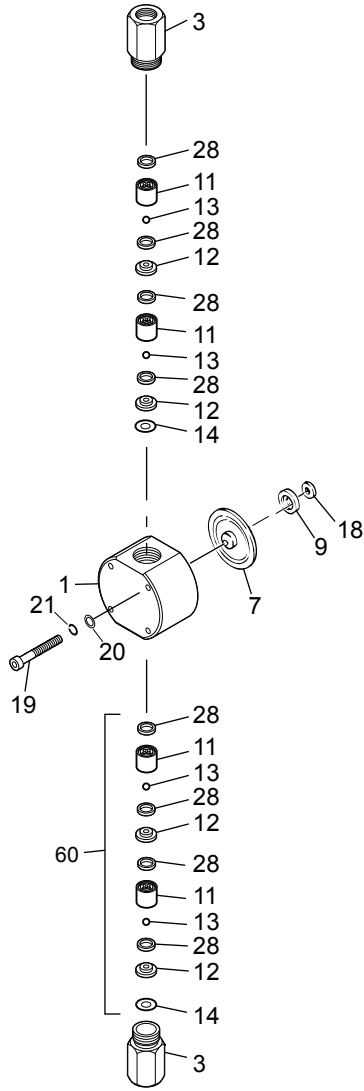

Item	Part#	Description	Qty	Material	Size
1	EH2021	Pump Head	1	316SS	B11
	EH2176		1	316SS	B16 / C16
	EH2022		1	316SS	B21 / C21
	EH2023		1	316SS	B31 / C31
	EH2024		1	316SS	C36
3	EH0429	Housing, Valve	2	316SS	B11,16,21 / C16,21
	EH0433		2	316SS	B31 / C31,36
*7	EH1971	Diaphragm	1	PTFE+EPDM	B11
	EH1972		1	PTFE+EPDM	B16 / C16
	EH1973		1	PTFE+EPDM	B21 / C21
	EH1974		1	PTFE+EPDM	B31 / C31
	EH1975		1	PTFE+EPDM	C36
*9	EH0059	Retainer	1	PPS+GF	B11
	EH0083		1	PPS+GF	B16 / C16
	EH0067		1	PPS+GF	B21 / C21
	EH0087		1	PPS+GF	B31 / C31
	EH0158		1	PPS+GF	C36
11	EH0360	Guide, Valve	4	316SS	B11
	EH1551		4	316SS	B16,21 / C16,21
	EH1552		4	316SS	B31 / C31,36
12	EH1554	Seat, Valve	4	316SS	B11
	EH1555		4	316SS	B16,21 / C16,21
	EH1556		4	316SS	B31 / C31,36
13	EH0049	Ball, Valve	4	HC	B11
	EH0072		4	HC	B16,21 / C16,21
	EH0126		4	HC	B31 / C31,36
*14	EH0362	Gasket, Valve Housing	2	PTFE	B11,16,21 / C16,21
	EH0380		2	PTFE	B31 / C31,36
19	EH2089	Bolt, Hex Socket	4	M4×45	B11,16,21,31 / C16,21
	EH2090		4	M5×45	C-31,36
20	EH1999	Washer, Plate, M4	4	316SS	B11,16,21,31 / C16,21
	EH2011	Washer, Plate, M5	4	316SS	C-31,36
21	EH2000	Washer, Split, M4	4	316SS	B11,16,21,31 / C16,21
	EH2012	Washer, Split, M5	4	316SS	C-31,36
*28	EH0365	Gasket, Valve	8	PTFE	B11,16,21 / C16,21
	EH0382		8	PTFE	B31 / C31,36
18	-----	Brass Spacers	--	Brass	Drive Specific. Reuse with Dia. change

*** Parts Included in the Spart Parts Kits**

Accessories (Not Shown)

Part No.	Description	Size	Liquid End Mtl
CAN-1VC-7	Valve, Injection 3/8	11, 16, 21	VC
CAN-1VE-7	Valve, Injection 3/8	11, 16, 21	VE, VF
CAN-1PA-7	Valve, Injection 3/8	11, 16, 21	PA
CAN-1PC-7	Valve, Injection, 3/8	11, 16, 21	PC
CAN-1PE-7	Valve, Injection, 3/8	11, 16, 21	PE
CAN-2VCL-8	Valve, Injection, 1/2	31, 36	VC
CAN-2VEL-8	Valve, Injection, 1/2	31, 36	VE, VF
CAN-2PAL-8	Valve, Injection, 1/2	31, 36	PA
CAN-2PCL-8	Valve, Injection, 1/2	31, 36	PC
CAN-2PEL-8	Valve, Injection, 1/2	31, 36	PE
E90238	Valve, Injection, 3/8	11, 16, 21	TC
E90020	Valve, Inj/Back Press, 3/8	11, 16, 21	FC, TA
E90022	Valve, Inj/Back Press, 1/2	31, 35	TC, FC, TA
E90013	Valve, Foot, 3/8	11, 16, 21	VC
E90015	Valve, Foot, 3/8	11, 16, 21	PC
E90016	Valve, Foot, 1/2	31, 36	VC
E90018	Valve, Foot, 1/2	31, 36	PC
E90034	Valve, Foot, 3/8	11, 16, 21	PE
E90919	Valve, Foot, 3/8	11, 16, 21	PA
E90954	Valve, Foot, 3/8	11, 16, 21	TA
E90035	Valve, Foot, 3/8	11, 16, 21	VE
E90961	Valve, Foot, 1/2	31, 36	PA
E90036	Valve, Foot, 1/2	31, 36	PE
E90967	Valve, Foot, 1/2	31, 36	TA
E90037	Valve, Foot, 1/2	31, 36	VE
E90193	Valve, Foot, 1/2	31, 36	VF
E90234	Valve, Foot, 3/8	11, 16, 21	VF
E90239	Valve, Foot, 1/2	31, 36	TC
E90240	Valve, Foot, 3/8	11, 16, 21	TC
E90241	Valve, Foot, 3/8	11, 16, 21	FC
E90275	Valve, Foot, 1/2	31, 36	FC
E00001	Tubing, 1/2 OD LLDPE, 20 FT	31, 36	all
E00001-50	Tubing, 1/2 OD LLDPE, 50 FT	31, 36	all
E00001-100	Tubing, 1/2 OD LLDPE, 100 FT	31, 36	all
E00001-500	Tubing, 1/2 OD LLDPE, 500 FT	31, 36	all
E00002	Tubing, 3/8 OD LLDPE, 20 FT	11, 16, 21	all
E00002-50	Tubing, 3/8 OD LLDPE, 50 FT	11, 16, 21	all
E00002-100	Tubing, 3/8 OD LLDPE, 100 FT	11, 16, 21	all
E00002-500	Tubing, 3/8 OD LLDPE, 500 FT	11, 16, 21	all
E00074-20	Tubing, 1/2 OD LLDPE, UV Resistant, 20 FT	31, 36	all
E00074-50	Tubing, 1/2 OD LLDPE, UV Resistant, 50 FT	31, 36	all
E00074-100	Tubing, 1/2 OD LLDPE, UV Resistant, 100 FT	31, 36	all
E00074-500	Tubing, 1/2 OD LLDPE, UV Resistant, 500 FT	31, 36	all
E00075-20	Tubing, 3/8 OD LLDPE, UV Resistant, 20 FT	11, 16, 21	all
E00075-50	Tubing, 3/8 OD LLDPE, UV Resistant, 50 FT	11, 16, 21	all
E00075-100	Tubing, 3/8 OD LLDPE, UV Resistant, 100 FT	11, 16, 21	all
E00075-500	Tubing, 3/8 OD LLDPE, UV Resistant, 500 FT	11, 16, 21	all
E00071	Weight, Ceramic	all	all

Drive and Control Module Exploded View

B: D-CONTROL MODULE

T-CONTROL MODULE

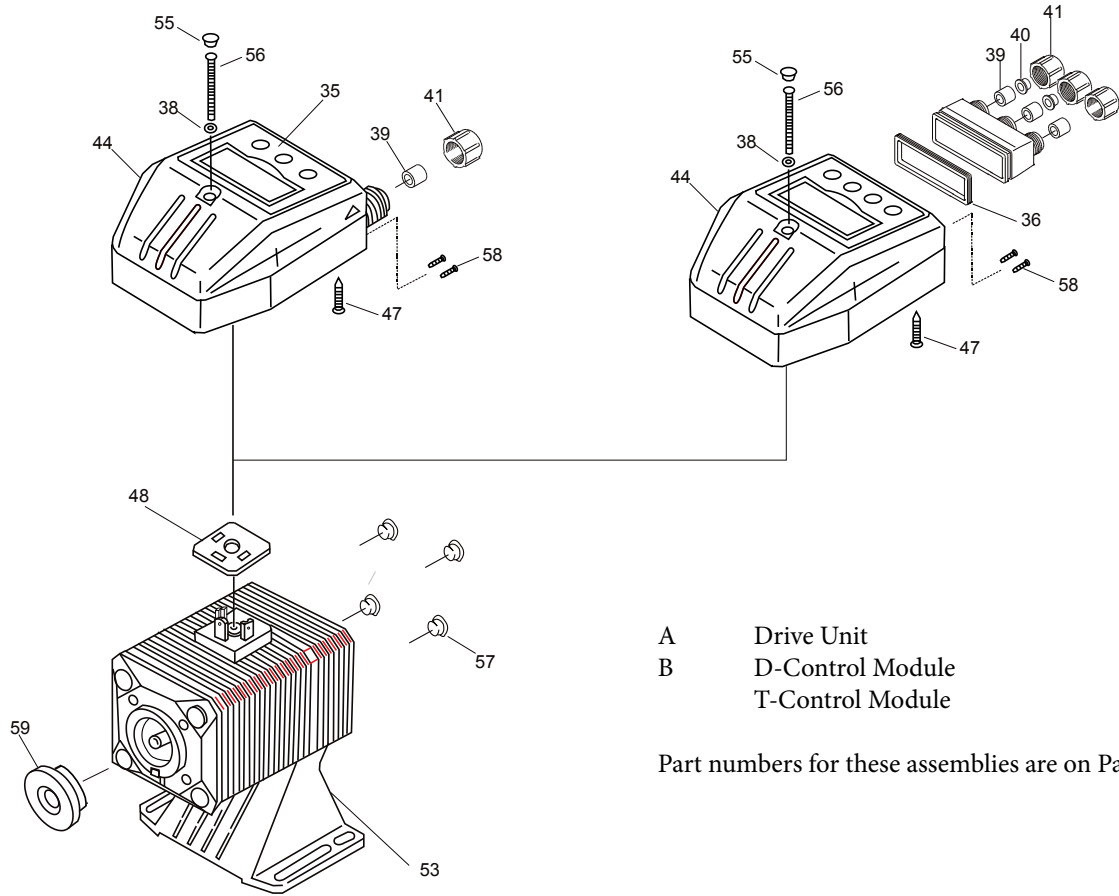

- A Drive Unit
- B D-Control Module
- T-Control Module

Part numbers for these assemblies are on Page 26

A: DRIVE UNIT

Item	Part No.	Description	Series
35	E00152	Cover, Keypad	EZ-D
	E00153	Membrane Keypad	EZ-D
36	EH1036	Gasket, Terminal Box	EZ-T
38	EH0261	Gasket, M3 x 35 Bolt	EZ-D, EZ-T
39	EH0202	Grommet, Cord	EZ-D, EZ-T
40	EH0204	Cap, Strain Relief	EZ-D, EZ-T
41	EH0205	Nut, Strain Relief	EZ-D, EZ-T
47	EH0269	Screw, Control Module	EZ-D, EZ-T
48	EH0547	Gasket, Terminal Block	EZ-D, EZ-T
53	1110027300	Base, EZ-C, Blue	EZC
	1120357900	Base, EZ-B, Blue	EZB
55	EH0289	Plug, Control Module	EZ-D, EZ-T
56	EH0241	Screw, M3 x 35 SS PH	EZ-D, EZ-T
57	EH0549	Plug, Bolt	EZ-D, EZ-T
58	EH1438	Screw, Self Tap, D-module	EZ-D, EZ-T
59	EH1690	Spacer, Bracket, EZ-11	EZ-D, EZ-T
	EH1431	Spacer, Bracket, EZ-16	EZ-D, EZ-T
	EH1700	Spacer, Bracket, EZ-21	EZ-D, EZ-T
	EH1702	Spacer, Bracket, EZ-31	EZ-D, EZ-T
	EH1714	Spacer, Bracket, EZ-16	EZ-D

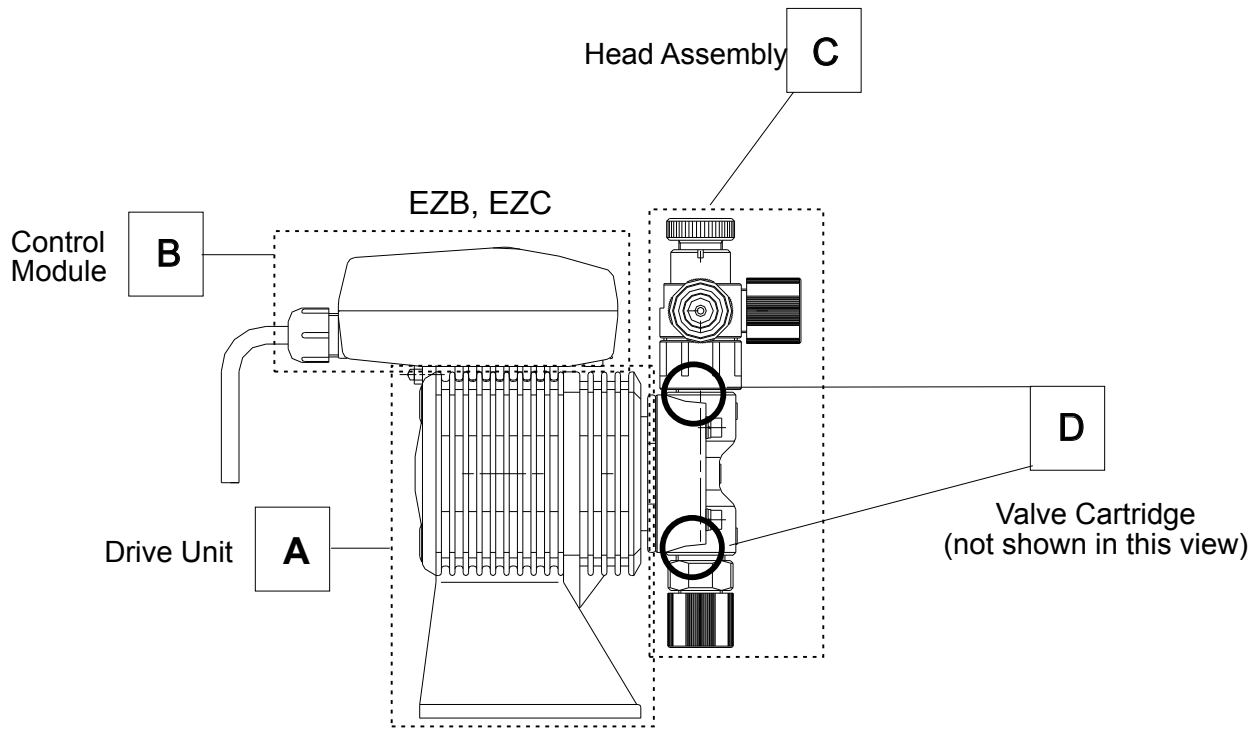

Key letters:

- A** Drive Unit
- B** Control Module
- C** Head Assembly
- D** Valve Cartridge

			C Head Assembly* (Spare Parts Kits)								
Pump Model	A Drive Unit	B Control Module	PC	PE	PA	VC	VE	VF	TC	TA	FC
EZB11D1-	ZB11-D1	EZBD1	Nzb11□								
EZB11D2-	N/A	N/A	(N11□-PK)								
EZB16D1-	ZB16-D1	EZBD1	Nzb16□								
EZB16D2-	N/A	N/A	(N16□-PK)								
EZB21D1-	ZB21-D1	EZBD1	Nzb21□								
EZB21D2-	N/A	N/A	(N21□-PK)								
EZB31D1-	ZB31-D1	EZBD1	Nzb31□								
EZB31D2-	N/A	N/A	(N31□-PK)								
EZC16D1-	ZC16-D1	EZCD1	N16□								
EZC16D2-	ZC16-D2	EZCD2	(N16□-PK)								
EZC21D1-	ZC21-D1	EZCD1	N21□								
EZC21D2-	ZC21-D2	EZCD2	(N21□-PK)								
EZC31D1-	ZC31-D1	EZCD1	N31□								
EZC31D2-	ZC31-D2	EZCD2	(N31□-PK)								
EZC36D1-	ZC36-D1	EZCD1	N36□								
EZC36D2-	ZC36-D2	EZCD2	(N36□-PK)								
			PC	PE	PA	VC	VE	VF	TC	FC	
D Valve Cartridge	11		E90041	E90042	E91232	E90038	E90039	E90302	E90305	E90044	
	16, 21		E90048	E90049	E91231	E90045	E90046	E90303	E90306	E90051	
	31, 36		E90055	E90056	---	E90052	E90053	E90304	---	---	
E Automatic Air Vent Valve	11, 16, 21		---	---	---	ADV-V□-7		---	---	---	
F Multi- Function Valve Assembly	11, 16, 21		MFV-HTC-7 (B11/16, C16/21) / MFV-MTC-7 (B21)								
	31, 36		MFV-MTC-8 (C31) / MFV-LTC-8 (B31/C36)								

Notes: * The P/N in the block is the head assembly part number and the spare parts kit is shown underneath in parentheses. For head assemblies with a Multifunction Valve, add an “M” to the end of the part number.

Parts kits for pumps with Multifunction valves are the same as pumps without the “M” option. (Parts kits for MFVs available separately)

For pump models using a “T” Control Module, change the ‘D’ in the model number or part number to a “T” to create the correct Control Module part number.

For head assemblies or parts kits with the Auto Degassing Valve, add “A” after the “VC” or “VE” code in the number.

6.0 TROUBLESHOOTING



CAUTION: Before working on the pump, disconnect the power cord, depressurize the discharge tubing and drain or flush any residual liquid from the pump head and valves, using proper chemical handling techniques.

Problem	Possible Cause	Corrective Action
Pump does not start	Faulty wiring	Correct wiring
	Improper voltage	Connect to proper voltage source
	Electronic control unit is damaged	Replace control unit (Contact distributor or factory)
Pump does not prime	Air in suction tubing	Reroute suction tubing to eliminate air trap
	Valve gasket is not installed	Install valve gasket
	Valve set assembly direction is wrong.	Reassemble valve set
	Pump is air locked	Open air vent valve
	Suction or discharge valve is clogged with foreign matter	Disassemble, inspect, clean
	Ball stuck to valve seat	Disassemble, inspect, clean
Output fluctuates	Suction or discharge valve is clogged with foreign matter	Disassemble, inspect, clean
	Air is trapped in pump	Open air vent valve
	Overfeeding	Install injection valve or back pressure valve
	Diaphragm is damaged	Replace diaphragm
Liquid leaks	Fitting or coupling nut is loose	Re-install (see section 2.3/2.4)
	Pump head is loose	Tighten pump head bolts Torque: 19 lb-in (2.16 N-m)
	Diaphragm is damaged	Replace diaphragm
	O-ring or valve gasket missing	Install o-ring or valve gasket

7.0 SERVICE POLICY

The EZ Series electronic metering pumps have a 2-year warranty. Contact your Walchem distributor for service.