

Fluidol Wedgee™ Packing Set

WEDGEE™

An Innovative Packing Solution that Will Extend Packing Life and Reduce Leakage

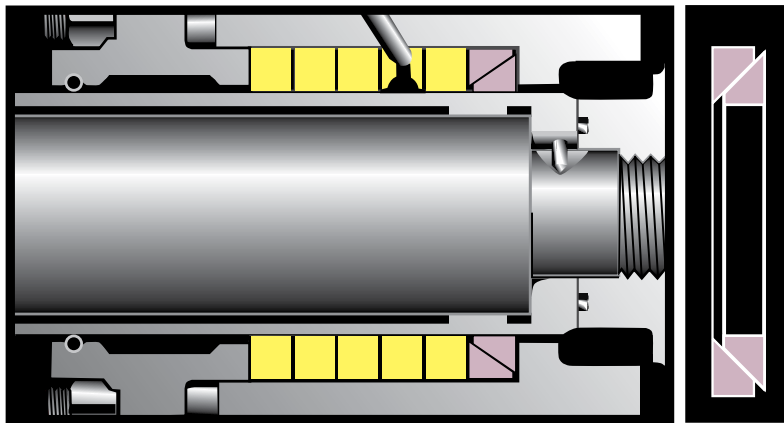

User Benefits:

- Reduces Leakage by Two-Thirds
- Extends Packing Life by 2-3 Times
- Eliminates/Reduces Need for Flush

For Ease of Installation

- Pre-Cut Packing Rings
- All Components are Split
- No Modification of Pump is Required

Where Used:

- Gear Pumps
- Centrifugal Pumps
- Progressing Cavity Pumps
- Agitators and Blenders
- Hydropulpers and Refiners

Fluid Applications:

- Asphalt/Filled Asphalt
- Gypsum
- River Raw Water Intake
- Dirty Plant/Mill Water
- Paper Stock
- Starch for Boxboard
- Municipal Sludge
- Industrial Sludge
- Wastewater

Before



After



Features:

- Two-Piece Teflon® Wedge Seal fitted to the bottom of the stuffing box
 - Provides close clearance flow restriction at the bottom of the stuffing box, and
 - Filters out abrasive solids that otherwise would damage the shaft and/or packing.



- Mixed Media Packing Sets
 - Self-lubricating packing next to the gland where effective sealing work is done, and
 - Dense and hard Intermediate rings transfer force to keep the two-piece wedge seal closed.

Specialized Grades of Wedgee™ Packing Sets

- Industrial & Abrasive Duty
- Food Grade (FDA compatible materials)
- Chemical Duty (Extended pH range)
- High Temperature (Over 500° F / 260° C)
- Optional Configurations with Lantern Ring

Call or Email Fluidol/Fluidol Distributor to Start Reducing Leakage and Downtime!

Choose *Fluidol Wedgee™ Packing Sets!*

FLUIDOL®

2125 S. James Rd.
Columbus, OH 43232

Ph: 614-239-7811
Fax: 614-239-7850

Email: sales@fluidol.com
www.fluidol.com