

## Fluidol Food Grade Wedgee™ Packing Set

# FG WEDGEE™

*An Innovative Food Grade Packing Solution that Will Reduce Leakage and Extend Packing Life*

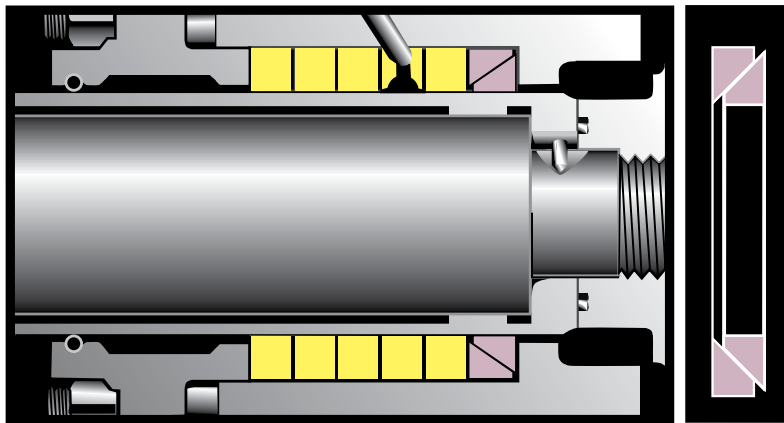

### User Benefits:

- Reduces Leakage by Two-Thirds
- Extends Packing Life by 2-3 Times
- Eliminates/Reduces Need for Flush

### For Ease of Installation

- Pre-Cut Packing Rings
- All Components are Split
- No Modification of Equipment is Required

### Where Used:

- Gear Pumps
- Centrifugal Pumps
- Progressing Cavity Pumps
- Dryers and Evaporators
- Cookers
- Mixers and Blenders

### FG Fluid Applications:

- Molasses
- Corn Syrup
- Vegetable Oil
- Shortening
- Tallow, Lard
- Peanut Butter
- Candy Mass
- Gels
- Animal Feed Ingredients
- Mash

**Before**



**After**



## Features:

- Two-Piece Teflon® Wedge Seal fitted to the bottom of the stuffing box
  - Provides close clearance flow restriction at the bottom of the stuffing box, and
  - Filters out abrasive solids that otherwise would damage the shaft and/or packing.
  - Keeps worn bits of packing from getting into the process fluid.

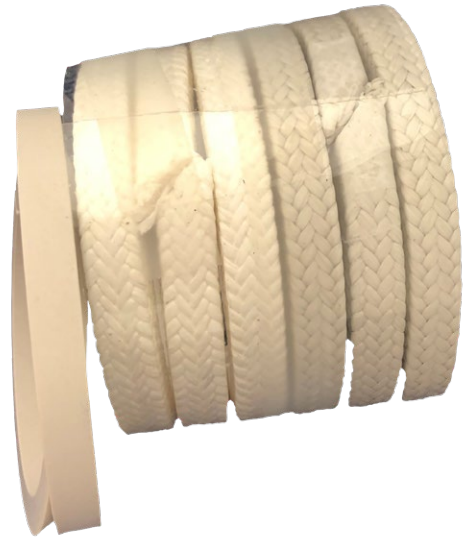

- Mixed Media Food Grade Packing Sets
  - Self-lubricating packing next to the gland where effective sealing work is done, and
  - Dense tightly woven Intermediate rings transfer force to keep the two-piece wedge seal closed.

## Specialized Grades of Wedgee™ Packing Sets

- Industrial & Abrasive Duty
- Food Grade (FDA compatible materials)
- Chemical Duty (Extended pH range)
- High Temperature (Over 500° F / 260° C)
- Optional Configurations with Lantern Ring

Call or Email Fluidol/Fluidol Distributor to Start Reducing Leakage and Downtime!

Choose *Food Grade Fluidol Wedgee™ Packing Sets!*

# FLUIDOL®

2125 S. James Rd.  
Columbus, OH 43232

Ph: 614-239-7811  
Fax: 614-239-7850

Email: [sales@fluidol.com](mailto:sales@fluidol.com)  
[www.fluidol.com](http://www.fluidol.com)