

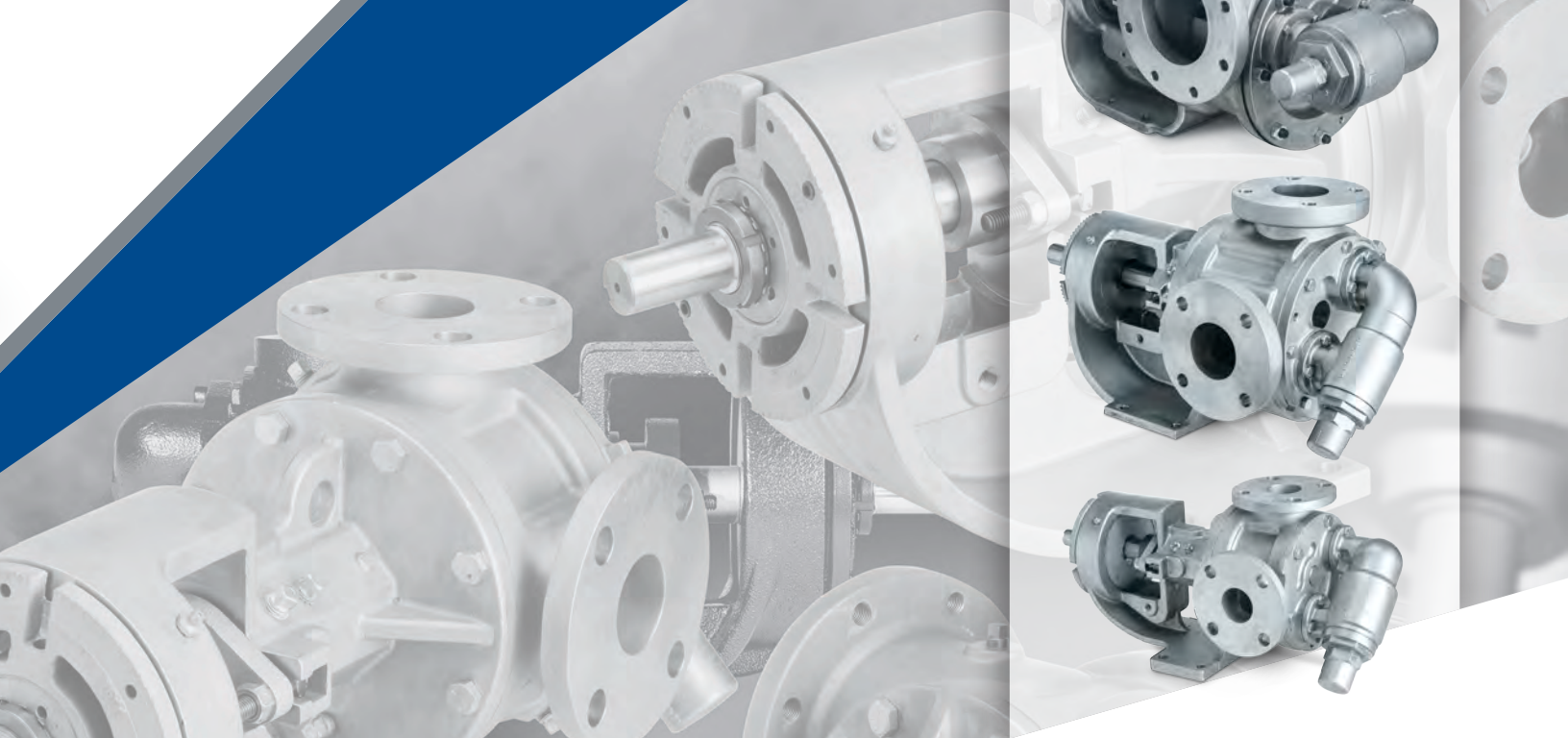

**G Series**  
Internal Gear  
Pumps



Where Innovation Flows

[envirogearpump.com](http://envirogearpump.com)



**EnviroGear®**, a product brand of PSG®, a Dover company, is a global provider of innovative, high-quality industrial gear pumps for the safe and efficient transfer of high-value and hard-to-seal fluids.

EnviroGear G Series Internal Gear Pumps are durable, flexible and efficient positive displacement gear pumps that excel in challenging fluid-handling applications. They are a high-quality, reliable alternative to competitive models, and backed by responsive and experienced customer service and factory support.

Not only does the EnviroGear G Series pump offer the best lead times and warranty in the industry, but its manufacturing quality and price are second to none. Combine this with the interchangeability of the G Series, and it puts these pumps in a league of their own. Simply put, you cannot find another internal gear pump that offers a lower upfront cost, lower total cost of ownership or less risk than the G Series.

## World-Class Manufacturing Facility

- **Supply Chain:** Every component that goes into an EnviroGear pump is put through a rigid Production Part Approval Process (PPAP) that ensures quality and reliability.
- **Quality Manufacturing:** 100% of EnviroGear pumps are tested for flow, pressure and power before leaving the factory. The facilities are ISO 9001/14001 compliant, and feature state-of-the-art coordinate-measuring machines and 3D-scanning equipment that ensure the highest level of part quality.
- **Testing Capabilities:** The R&D and testing laboratory is compliant to Hydraulic Institute 3.6 Standards, providing certified performance, NPSH and hydrostatic testing.
- **Global Support:** A full-service global distribution network is ready to serve new or existing EnviroGear pump installations and is backed by responsive factory support.

## Industry Leading Customer Service and Factory Support



*5-Year Limited Warranty*



*15 Day Factory Lead Time for Pumps*

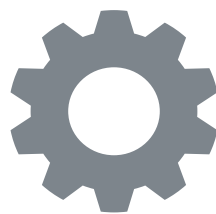

*5 Day Factory Lead Time for Parts*



*Competitive Prices*



*TRCU Compliant*

## Applications Section

G Series pumps are excellent for transferring fluids with a wide range of viscosities where consistent, non-pulsating flow rate is required. With only two moving parts, the pump operates equally well in both clockwise and counterclockwise directions. The pump casing can be repositioned to allow for multiple inlet and discharge positions for ultimate flexibility. The G Series pump is also offered with multiple internal clearance options and single-point end-clearance adjustment to maximize efficiency and pump life based on your application's viscosity, temperature and fluid characteristics.

- Adhesives
- Biofuels
- Bitumen products
- Chemicals
- Crude oil and fuel oils
- Edible fats and oils
- Equipment lubricants
- Food processing
- Heat-transfer fluids
- Lube oils and greases
- Molten sulfur
- Paint and coatings
- Petrochemicals and additives
- Polyols
- Polyurethane
- Pigments and dyes
- Resins
- Soap and detergents
- Sugars and sweeteners
- Surfactants
- Polymers

# EnviroGear G Series Pump

## Competitor Pump Interchangeability

G Series pumps are interchangeable with up to 95% of the mechanically sealed, packed and seal-less internal gear pumps in use today. Replacing an existing pump with a G Series usually requires no modifications to the piping, driver, baseplate or coupling, while keeping flow rates unchanged. G Series pumps are designed to be part-for-part replacements for many Viking® pump models and are available in cast iron, carbon steel and stainless steel.

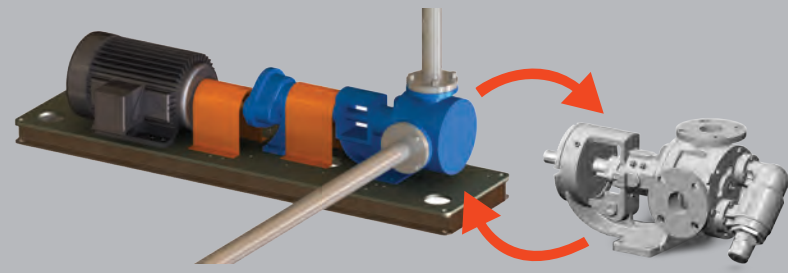

## Direct Replacement Part Interchangeability

G Series parts are designed to be direct replacements for Viking® H, HL, K, KK, L, LQ, LL, LS, Q and QS models. Available in cast iron, carbon steel and stainless steel construction. Most parts ship within 3-5 business days. Expedite programs are also available.



## Single-Point End-Clearance Adjustment

A threaded bearing housing allows the rotor end clearance to be adjusted with simple hand tools in order to compensate for wear and restore optimal pump performance.

## Seal Chamber with Universal Design

An oversized bracket and seal chamber allows the acceptance of numerous sealing technologies, including packing, component mechanical seals, cartridge mechanical seals and lip seals. The seal chamber also accepts various seal flush-plans.

## Flexible Case Orientation

Bidirectional performance for loading/unloading applications and the ability to rotate in 45° increments for eight unique port positions.

## Internal Clearance Options

A wide range of internal clearance options are available to offer optimal performance in a wide range of applications.

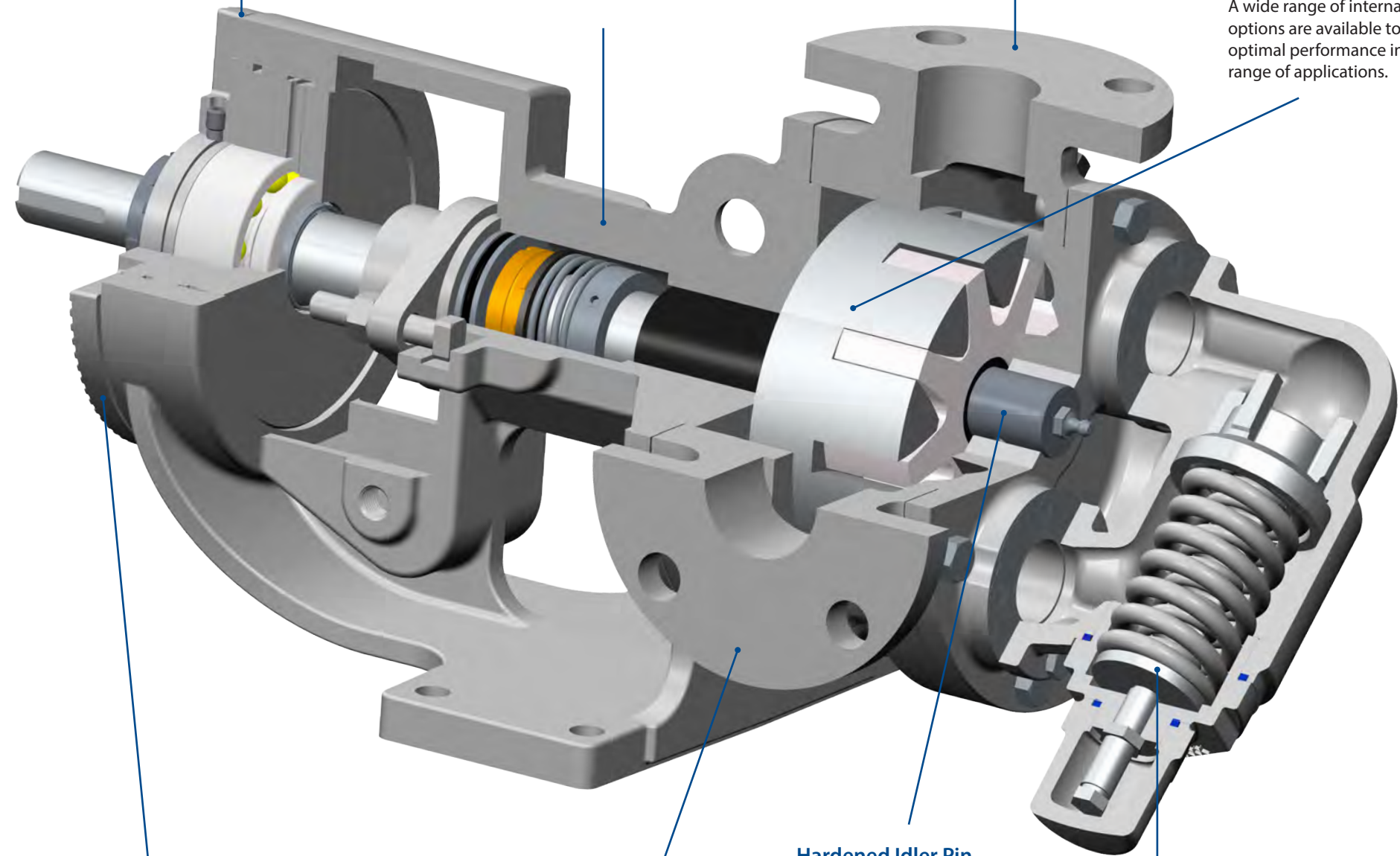

## Heavy-Duty Oversized Bearing Housing

The cast-iron bearing housing is guaranteed to last the life of the pump, while competitive pump models use low-strength, low-cost aluminum bearing housings that can be prone to early failure. The large size of the G Series bearing housing also allows the mechanical seals to be removed without the need to take the pump out of service.

## Materials of Construction

Wetted parts are available in cast iron, carbon steel and stainless steel to meet application requirements. See material of construction table for more details.

## Hardened Idler Pin

Standard on all pump sizes, with multiple materials of construction available.

## Pressure Relief Valve

Multiple options are available to protect the pump from over-pressure conditions. Pumps can also be ordered without a pressure relief valve.



## Sizes Available

Model	Cast Iron Port Sizes <sup>1</sup>	Carbon Steel Port Sizes <sup>2</sup>	Stainless Steel Port Sizes <sup>2</sup>
G1-2	1-1/2" NPT	1-1/2" ANSI	1-1/2" ANSI
G1-4	1-1/2" NPT	1-1/2" ANSI	1-1/2" ANSI
G1-24	2" NPT	2" ANSI	2" ANSI
G1-32	2" NPT	2" ANSI	2" ANSI
G1-55	2" NPT or 2-1/2" ANSI	2-1/2" ANSI	2-1/2" ANSI
G1-69	3" ANSI	3" ANSI	3" ANSI
G1-82	3" ANSI	3" ANSI	3" ANSI
G1-133	4" ANSI	4" ANSI	4" ANSI
G1-222	6" ANSI	6" ANSI	6" ANSI

(1) Flanged connections meet Class 125# ANSI  
 (2) Flanged connections meet Class 150# ANSI

## Pump Selection Performance Criteria

Model	Nominal Pump Rating			Max. Discharge Pressure			Max. Temperature			Model	Nominal Pump Rating			Max. Discharge Pressure			Max. Temperature				
	RPM	GPM (m <sup>3</sup> /h)	PSIG (bar)	Fahrenheit (Celsius)	RPM	GPM (m <sup>3</sup> /h)	PSIG (bar)	Fahrenheit (Celsius)	RPM		GPM (m <sup>3</sup> /h)	PSIG (bar)	Fahrenheit (Celsius)	RPM	GPM (m <sup>3</sup> /h)	PSIG (bar)	Fahrenheit (Celsius)				
	Cast Iron						Carbon Steel						Stainless Steel								
G1-2	1,750	15 (3.4)	200 (13.8) >20 cSt	650° (343°)	1,750	15 (3.4)	200 (13.8) >20 cSt	650° (343°)	1,150	10 (2.3)	150 (10.3) >550 cSt	500° (260°)	G1-4	1,750	30 (6.8)	200 (13.8) >20 cSt	650° (343°)	1,150	20 (4.5)	150 (10.3) >550 cSt	500° (260°)
G1-24	780	75 (17.0)	200 (13.8) >20 cSt	650° (343°)	780	75 (17.0)	200 (13.8) >20 cSt	650° (343°)	520	50 (11.4)	150 (10.3) >550 cSt	500° (260°)	G1-32	780	100 (22.7)	200 (13.8) >20 cSt	650° (343°)	520	65 (14.8)	150 (10.3) >550 cSt	500° (260°)
G1-55	640	135 (30.7)	200 (13.8) >20 cSt	650° (343°)	640	135 (30.7)	200 (13.8) >20 cSt	650° (343°)	420	90 (20.4)	150 (10.3) >550 cSt	500° (260°)	G1-69	520	140 (31.8)	200 (13.8) >20 cSt	650° (343°)	420	110 (25.0)	150 (10.3) >550 cSt	500° (260°)
G1-82	640	200 (45.4)	200 (13.8) >165 cSt	500° (260°)	640	200 (45.4)	200 (13.8) >165 cSt	500° (260°)	520	160 (36.3)	125 (8.6) >25 cSt	500° (260°)	G1-133	520	300 (68.1)	200 (13.8) >165 cSt	500° (260°)	350	200 (45.4)	125 (8.6) >25 cSt	500° (260°)
G1-222	520	500 (113.6)	200 (13.8) >165 cSt	500° (260°)	520	500 (113.6)	200 (13.8) >165 cSt	500° (260°)	350	320 (72.7)	125 (8.6) >25 cSt	500° (260°)									

(1) Maximum pressure listed reflects maximum differential pressure and maximum allowable working pressure.  
 (2) Values listed in table are nominal and for reference only. To ensure proper pump selection, always refer to EnviroGear Select.

## Materials of Construction

Description	Part	Cast Iron	Carbon Steel	Stainless Steel	
Pressure Containing	Case	Cast Iron, ASTM A48 Class 35B	Carbon Steel, ASTM A216 Grade WCB	Stainless Steel, ASTM A743 Grade CF8M	
	Head	Cast Iron, ASTM A48 Class 35B	Carbon Steel, ASTM A216 Grade WCB	Stainless Steel, ASTM A743 Grade CF8M	
	Bracket	Cast Iron, ASTM A48 Class 35B	Carbon Steel, ASTM A216 Grade WCB	Stainless Steel, ASTM A743 Grade CF8M	
	Pressure Relief Valve	Cast Iron, ASTM A48 Class 35B	Carbon Steel, ASTM A216 Grade WCB	Stainless Steel, ASTM A743 Grade CF8M	
Product Contact	Idler Gear	Cast Iron, ASTM A48 Class 35B <sup>1</sup>		Stainless Steel, ASTM A564 Type 630 (17-4PH) <sup>5</sup>	
	Rotor	Standard	Cast Iron, ASTM A48 Class 35B <sup>2,4</sup>		Stainless Steel, ASTM A564 Type 630 (17-4PH) <sup>5</sup>
		Steel Fitted	Carbon Steel, ASTM A311 Grade 1045 Class A <sup>3,4</sup>		N/A
	Rotor Shaft	Steel, ASTM A311 Grade 1045		Stainless Steel, ASTM A276 Grade 316	
	Idler Pin	Alloy Steel, Hardened		Stainless Steel, Hardened	
	Idler Bushing	Carbon Graphite, Bronze, Tungsten Carbide		Carbon Graphite, Tungsten Carbide	
Bracket Bushing	Carbon Graphite, Bronze, Tungsten Carbide		Carbon Graphite, Tungsten Carbide		
Non-Product Contact	Bearing Housing	Cast Iron, ASTM A48 Class 35B			

<sup>1</sup> Cast iron and carbon steel G1-133 and G1-222 come standard with ductile iron idler ASTM A536 Grade 80-55-06  
<sup>2</sup> Cast iron and carbon steel G1-32 come standard with ductile iron rotor ASTM A536 Grade 60-40-18  
<sup>3</sup> Cast iron and carbon steel G1-4 steel fitted come with alloy steel grade 8620 rotor  
<sup>4</sup> Cast iron and carbon steel G1-82, G1-133 and G1-222 standard and steel fitted come with ductile iron rotor ASTM A536 Grade 80-55-06  
<sup>5</sup> Stainless steel G1-82, G1-133 and G1-222 come standard with Nitronic 60, ASTM A276, UNS21800 rotor and idler

## Model Cross Reference

G Series	E Series	Viking®	Tuthill®	Gorman-Rupp®
G1-2	E1-2	H	015	GHS 1-1/2
G1-4	E1-4	HL	030	GHS 1-1/2
G1-24	E1-24	K	120	GHS 2
G1-32	E1-32	KK	130	GHS 2
G1-55	E1-55	L & LQ	200	GHS 2-1/2, 3
G1-69	E1-69	LL	210	GHS 3
G1-82	E1-82	LS	250	GHS 3
G1-133	E1-133	Q	N/A	GHS 4
G1-222	E1-222	QS	550	GHS 6

Viking® is a registered trademark of Viking Pump, Inc., a unit of IDEX Corporation. Tuthill® is a registered trademark of Tuthill Corporation. Gorman-Rupp® is a registered trademark of Gorman-Rupp® Company.

## Where Innovation Flows



PSG  
22069 Van Buren Street  
Grand Terrace, CA 92313-5651  
P: +1 (909) 422-1731 • F: +1 (909) 783-3440  
[envirogearpump.com](http://envirogearpump.com)

PSG<sup>®</sup> reserves the right to modify the information and illustrations contained in this document without prior notice. This is a non-contractual document. 05-2017

Authorized PSG Partner: