

INSTALLATION, OPERATION AND MAINTENANCE MANUAL

WITH PARTS LIST

GH SERIES PUMP



MODEL

GH - 3

Thomas Pump & Machinery
120 Industrial Drive
Slidell, LA 70460

PH: 985-649-3000
Fax: 985-649-4300

TABLE OF CONTENTS

INTRODUCTION	Pg. 03
WARNING – SECTION	Pg. 04
INSTALLATION – SECTION B	Pg. 05
Pump Dimensions.....	Pg. 05
PREINSTALLATION INSPECTION.....	Pg. 06
POSITIONING PUMP.....	Pg. 06
Lifting.....	Pg. 06
Mounting.....	Pg. 06
Clearance.....	Pg. 06
SUCTION AND DISCHARGE PIPING.....	Pg. 06
Materials.....	Pg. 06
Line Configuration.....	Pg. 07
Connections to Pump.....	Pg. 07
Gauges.....	Pg. 07
SUCTION LINES.....	Pg. 07
Fittings.....	Pg. 07
Strainers.....	Pg. 07
Sealing.....	Pg. 07
Suction Lines in Sumps.....	Pg. 07
Suction Lines Positioning.....	Pg. 08
DISCHARGE LINES.....	Pg. 08
Siphoning.....	Pg. 08
Valves.....	Pg. 08
Bypass Lines.....	Pg. 09
AUTOMATIC AIR RELEASE VALVE.....	Pg. 10
Theory of Operation.....	Pg. 10
Air Release Valve Installation.....	Pg. 10
ALIGNMENT.....	Pg. 11
Coupled Drivers.....	Pg. 12
V-Belt Drives.....	Pg. 12
OPERATION – SECTION C	Pg. 14
PRIMING.....	Pg. 14
STARTING.....	Pg. 14
Rotation.....	Pg. 14
OPERATION.....	Pg. 15
Lines With a Bypass.....	Pg. 15
Lines Without a Bypass.....	Pg. 15
Leakage.....	Pg. 15
Liquids Temperature and Overheating.....	Pg. 15
Strainer Check.....	Pg. 16
Pump Vacuum Check.....	Pg. 16
STOPPING.....	Pg. 16
Cold Weather Preservation.....	Pg. 16
BEARING TEMPERATURE CHECK.....	Pg. 16

**TABLE OF CONTENTS
(Continued)**

TROUBLESHOOTING – SECTION D	Pg. 18
PUMP MAINTENANCE AND REPAIR – SECTION E.....	Pg. 21
PERFORMANCE CURVE.....	Pg. 21
Pump Model	Pg. 22
PARTS LISTS	Pg. 23
Repair Rotating Assembly.....	Pg. 24
PARTS LISTS	Pg. 25
PUMP AND SEAL DISASSEMBLY AND REASSEMBLY....	Pg. 26
Back Cover and Wear Plate Removal.....	Pg. 26
Suction Check Valve Removal.....	Pg. 26
Rotating Assembly Removal.....	Pg. 26
Impeller Removal.....	Pg. 27
Seal Removal.....	Pg. 28
Shaft and Bearing Removal and Disassembly.....	Pg. 28
Shaft and Bearing Reassembly and Installation.....	Pg. 29
Seal and Installation.....	Pg. 30
Impeller Installation.....	Pg. 32
Rotating Assembly Installation.....	Pg. 32
Suction Check Valve Installation.....	Pg. 33
Back Cover Installation.....	Pg. 33
PRESSURE RELIEF VALVE MAINTENANCE	Pg. 33
Final Pump Assembly	Pg. 34
LUBRICATION	Pg. 34
Seal Assembly	Pg. 34
Bearings	Pg. 34
Power Source	Pg. 34

INTRODUCTION

This Installation, Operation, and Maintenance manual is designed to help you get the best performance and longest life from your Gator Prime pump.

This pump is an GH Series, semi-open impeller, self priming centrifugal model with a suction check valve.

The pump is designed for handling mild industrial corrosives, mud or slurries containing large entrained solids. The basic material of construction is gray iron, with ductile iron impeller and steel wearing parts.

If there are any questions regarding the pump or its applications which are not covered in this manual or in other literature accompanying this unit, please contact your Gator Prime distributor:

Thomas Pump & Machinery, Inc.
120 Industrial Drive, Slidell, LA 70460, USA
PH: 985-649-3000 Fax: 985-649-4300

For information or technical assistance on the power source, contact the power source manufacture's local dealer or representative.

The following are used to alert maintenance personnel to procedures which require special attention, to those which could damage equipment, and to those which could be dangerous to personnel:



DANGER!

Immediate hazards which **WILL** result in severe personal injury or death. These instructions describe the procedure required and the injury which will result from failure to follow procedure.



CAUTION!

Hazards or unsafe practices which **COULD** result in minor personal injury or product or property damage. These instructions describe the requirements and the possible damage which could result from failure to follow the procedure.

NOTE

Instructions to aid in installation, operation, and maintenance or which clarify a procedure.

SAFETY – SECTION A

These warnings apply to GH series basic pumps. Thomas Pump has no control over or particular knowledge of the power source which will be used. Refer to the manual accompanying the power source before attempting to begin operation.



WARNING!

Before attempting to open or service the pump:

1. Familiarize yourself with this manual.
2. Disconnect or lock out the power source to ensure that the pump will remain inoperative.
3. Allow the pump to cool if overheated.
4. Check the temperature before opening any covers, plates, or plugs.
5. Close the suction and discharge valves.
6. Vent the pump slowly and cautiously.
7. Drain the pump



WARNING!

This pump is designed to handle mild industrial corrosives, mud or slurries containing large entrained solids. Do not attempt to pump volatile, corrosive, or flammable materials which may damage the pump or endanger personnel as result of pump failure.



WARNING!

After the pump has been positioned, make certain that the pump and all piping connections are tight, properly supported and secure before operation.



WARNING!

Do not operate the pump without the guards in place over the rotating parts. Exposed rotating parts can catch clothing, fingers, or tools, causing severe injury to personnel.



WARNING!

Do not remove plates, covers, gauges, pipe plugs, or fittings from an overheated pump. Vapor pressure within the pump can cause parts being disengaged to be ejected with great force. Allow the pump to cool before servicing.



WARNING!

Do not operate the pump against a closed discharge valve for long periods of time. If operated against a closed discharge valve, pump components will deteriorate, and the liquid could come to a boil, pressure, and cause the pump casing to rupture or explode .



WARNING!

Use lifting and moving equipment in good repair and with adequate capacity to prevent injuries to personnel or damage to equipment. Suction and discharge hoses and piping must be removed form the before lifting

INSTALLATION – SECTION B

Review all SAFETY information in Section A.

Since pump installations are seldom identical, this section offers only general recommendations and practices required to inspect, position and arrange the pump and piping.

Most of the information pertains to a standard **static lift application** where the pump is positioned above the level of liquid to be pumped.

If installed in a **flooded suction application** where the liquid is supplied to the pump under pressure, some of the information such as mounting, line configuration, and priming must be tailored to the specific application.

Since the pressure supplied to the pump is critical to performance and safety, **be sure** to limit incoming pressure to **50%** of the maximum permissible operating pressure as shown on the pump performance curve.

For further assistance, contact your Gator Prime distributor or Thomas Pump & Machinery.

Pump Dimensions

See Figure 1 for the approximate physical dimensions of this pump.

OUTLINE DRAWING

DIMENSIONS: **MILLIMETERS**
 (INCHES)

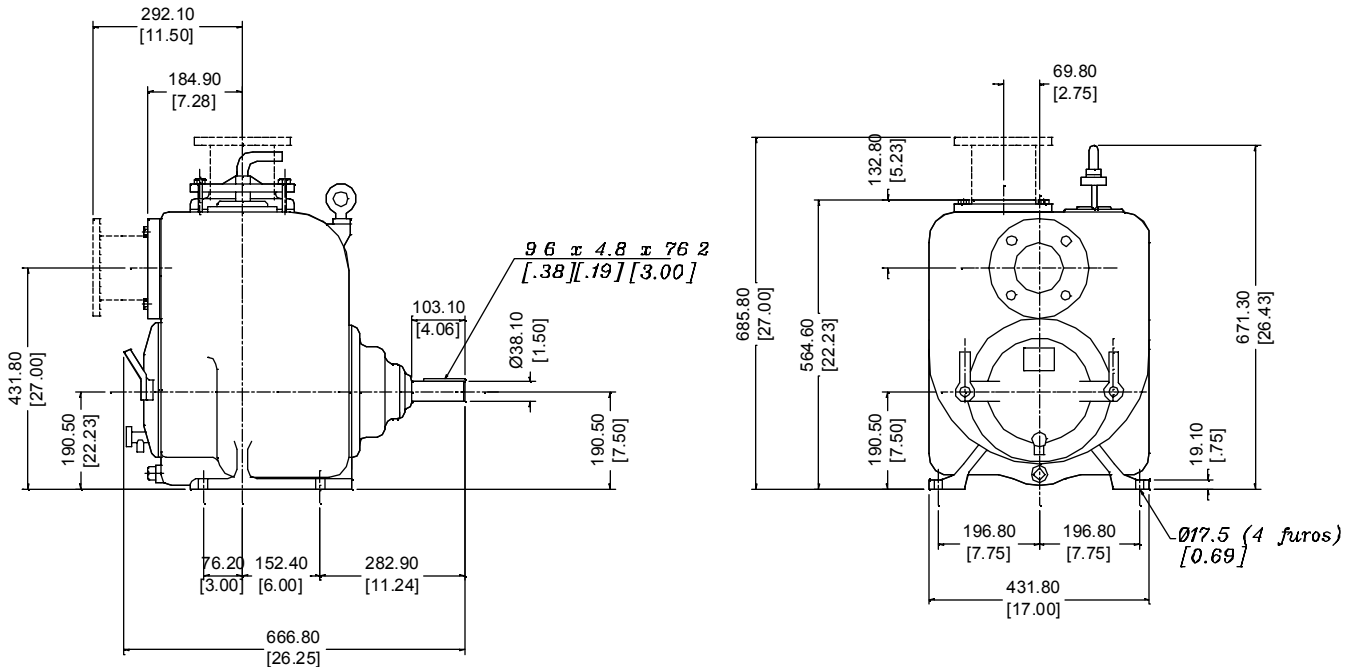

Figure 1. Pump Model GH-3

PREINSTALLATION INSPECTION

The pump assembly was inspected and tested before from the factory. Before installation, inspect the pump for damage which may have occurred during shipment. Check as follows:

- a. inspect the pump for cracks, dents, damaged threads, and other obvious damage.
- b. Check for and tighten loose attaching hardware. Since gaskets tend to shrink after drying, check for loose hardware at mating surfaces.
- c. Carefully read all warnings and cautions contained in this manual or affixed to the pump, and perform all duties indicated. Note the direction of rotation indicated on the pump. Check that the pump shaft rotates counterclockwise when facing the back cover plate assembly/impeller end of the pump.



Only operate this pump in the direction indicate by the arrow on the pump body and on the accompanying decal. Refer to ROTATION in OPERATION, Section C.

d. Check levels and lubricate as necessary. Refer to LUBRICATION in the MAINTENANCE AND REPAIR section of this manual and perform duties as instructed.

e. If the pump and power source have been stored for more than 12 months, some of the components or lubricants may have exceeded their maximum shelf life. These must be inspected or replaced to ensure maximum pump service.

If the maximum shelf life has been exceeded, or if anything appears to be abnormal, contact your Gator Prime distributor or the factory to determine the repair or updating policy. Do not put the pump into service until appropriate action has been taken.

POSITIONING PUMP

Lifting

Use lifting equipment with a capacity of at least **2500 pounds (1134 Kg)**. This pump weighs approximately **500 pounds (222 Kg)**, not including the weight of accessories and base. Customer installed equipment such as suction and discharge piping **must** be removed before attempting to lift.



The pump assembly can be seriously damaged if the cables or chains used to lift and move the unit are improperly wrapped around the pump.

Mounting

Locate the pump in an accessible place as close as practical to the liquid being pumped. Level mounting is essential for proper operation.

The pump may have to be supported or shimmed to provide for level operation or to eliminate vibration.

Clearance

When positioning the pump, allow a minimum clearance of 31 inches (800 mm) in front of the back cover to permit removal of the cover and easy access to the pump interior.

SUCTION AND DISCHARGE PIPING

Pump performance is adversely effected by increase suction lift, discharge elevation. And friction losses. See the performance curve and operating range shown on Page 21 to be sure your overall application allows pump to operate within the safe operation range.

Materials

Either pipe or hose maybe used for suction and discharge lines: however, the materials must be compatible with liquid being pumped.

If hose is used in suction lines, it must be the rigid-wall, reinforced type to prevent collapse under suction. Using piping couplings in suction lines is not recommended.

Line Configuration

Keep suction and discharge lines as straight as possible to minimize friction losses. Make minimum use of elbows and fittings, which substantially increase friction loss. If elbows are necessary, use the long radius type to minimize friction loss.

Connections to Pump

Before tightening a connecting flange, align it exactly with the pump port. Never pull a pipe line into place by tightening the flange bolts and/or couplings.

Lines near the pump must be independently supported to avoid strain on the pump which could cause excessive vibration, decrease bearing life, and increased shaft and seal wear. If hose-type lines are used, they should have adequate support to secure them when filled with liquid and under pressure.

Gauges

Most pumps are drilled and tapped for installing discharge pressure and vacuum suction gauges. If these gauges are desired for pumps that are not tapped, drill and tap the suction and discharge lines not less than 18 inches (457,2mm) from the suction and discharge ports and install the lines. Installation closer to the pump may result in erratic readings.

SUCTION LINES

To avoid air pockets which could affect pump priming, the suction line must be as short and direct as possible. When operation involves a suction lift, the line must always slope upward to the pump from the source of the liquid being pumped: if the line slopes down to the pump at any point along the suction run, air pockets will be created.

Fittings

Suction lines should be the same size as the pump inlet. If reducers are used in suction lines, they should be the eccentric type, and should be installed with the flat part of the reducers uppermost to avoid creating air pockets. Valves are not normally used in suction lines, but if a valve is used, install it with the horizontal to avoid air pockets.

Strainers

If a strainer is furnished with the pump, be certain to use it; any spherical solids which pass through a strainer furnished with the pump will also pass through the pump itself.

If a strainer is not furnished with the pump, but is installed by the pump user, make certain that the total area of the openings in the strainer is at least three or four times the cross section of the suction line, and that the openings will not permit passage of solids larger than the solids handling capability of the pump.

This pump is designed to handle up to 3/4 inch (19 mm) diameter spherical solids.

Sealing

Since even a slight leak will affect priming, head, and capacity, especially when operating with a high suction lift, all connections in the suction line should be sealed with pipe dope to ensure an airtight seal. Follow the sealant manufacturer's recommendations when selecting and applying the pipe dope. The pipe dope should be compatible with the liquid being pumped.

Suction Lines in Sumps

If a single suction line is installed in a sump, it should be positioned away from the wall of the sump at a distance equal to 1 ½ times the diameter of the suction line.

If there is a liquid flow from an open pipe into the sump, the flow should be kept away from the suction inlet because the inflow will carry air down into the sump, and air entering the suction line will reduce pump efficiency.

If it is necessary to position inflow close to the suction inlet, install a baffle between the inflow and the inlet in suction lines, it must be the rigid-wall, reinforced type to prevent collapse under suction. Using piping couplings in suction lines is not recommended. Suction inlet at a distance 1 ½ times the diameter of the suction pipe. The baffle will allow entrained air to escape from the liquid before it is drawn into the suction inlet.

If two suction lines are installed a single sump, the flow paths may interact, reducing the efficiency of one or both pumps. To avoid this, position the suction inlets so that they are separated by a distance equal to at least 3 times the diameter of the suction pipe.

Suction Line Positioning

The depth of submergence of the suction line is critical to efficient pump operation. Figure 2 shows Recommended minimum submergence vs. velocity.

NOTE

The pipe submergence required may be reduced by installing a standard pipe increaser fitting at the end of the suction line. The larger opening size will reduce the inlet velocity. Calculate the required submergence using the following formula based on the increased opening size (area or diameter).

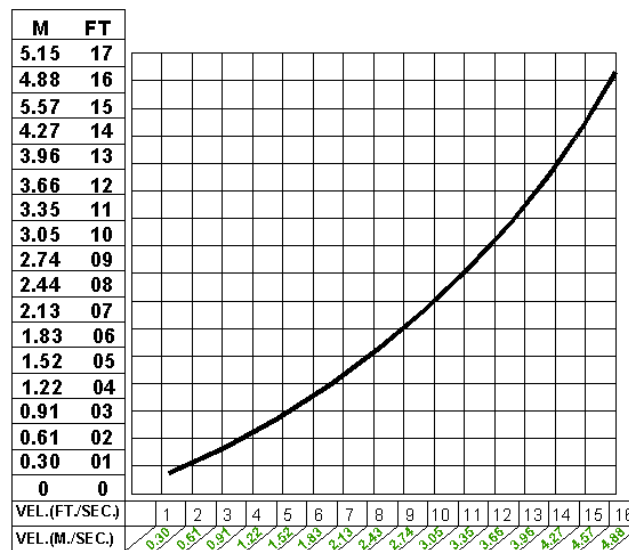

$$\text{VELOCITY (FT./SEC.)} = \frac{\text{QUANT. (G.P.M.)} \times 3.21}{\text{AREA}} \text{ OR } \frac{\text{G.P.M.} \times 4085}{D^2}$$

$$\text{VELOCITY (M./SEC.)} = \frac{\text{FLOW (M./MIN.)} \times 21.22}{\text{DIAMETER IN MM}^2} \text{ OR } \frac{\text{FLOW (M}^3\text{/SEC.)}}{\text{AREA IN M}^2}$$

Figure 2. Recommended Minimum Suction Line Submergence vs. Velocity

DISCHARGE LINES

Siphoning

Do not terminate the discharge line at a level lower than of the liquid being pumped unless a siphon breaker is used in the line. Otherwise, a siphoning action causing damage to the pump could result.

Valves

If a throttling valve is desired in the discharge line, use a valve as large as the largest pipe to minimize friction losses. Never install a throttling valve in a suction line.

With high discharge heads, it is recommended that a throttling valve and a system check valve be installed in the discharge line to protect the pump from excessive shock pressure and reverse rotation when it is stopped.



CAUTION!

If the application involves a high discharge head, gradually close the discharge throttling valve before stopping the pump.

Bypass Lines

Self-priming pumps are not air compressors. During the priming cycle, air from the suction line must be vented to atmosphere on the discharge side. If the discharge line is open, this air a check valve has been installed in the discharge line, the discharge side of the pump must be opened to atmospheric pressure through a bypass line installed between the pump discharge and the check valve. A self-priming centrifugal pump **will not prime** if there is sufficient static liquid head to hold the discharge check valve closed.

NOTE

The bypass line should be sized so that it does not affect pump discharge capacity; however, the bypass line should be at least 1 inch in diameter to minimize the chance of plugging.

In **low discharge head applications** (less than 30 feet or 9 meters), it is recommended that the bypass line be run back to the wet well, and locate 6 inches below the water level or cut-off point of the level pump. In some installations, this bypass line may be terminated with a six-to-eight foot length of 1 ¼ inch ID. **smooth-bore** hose; air and liquid vented during the priming process will then agitate the hose and break up any solids, grease, or other substances likely to cause clogging.



CAUTION!

A bypass line that is returned to a wet well must be secured against being drawn into the pump suction inlet.

It is also recommended that pipe unions be installed at each 90° elbow in a bypass line to ease disassembly and maintenance.

In **high discharge head applications** (more than 30 feet), an excessive amount of liquid may be bypassed and forced back to the wet well under the full working pressure of the pump; this will reduce overall pumping efficiency. **Therefore, it is recommended that a Gator Prime Automatic Air Release Valve be installed in the bypass line.**

Gator Prime Automatic Air Release Valves are reliable, and require minimum maintenance. See **AUTOMATIC AIR RELEASE VALVE** in this section for installation and theory of operation of the Automatic Air Release Valve. Contact Thomas Pump & Mach. for selection of an Automatic Air Release Valve to fit your application.

If the installation involves a flooded suction such as below-ground lift station. A pipe union and manual shut-off valve may be installed in the bleed line to allow service of the valve without shutting down the station, and to eliminate the possibility of flooding. If a manual shut-off valve is installed anywhere in the air release piping, it must be a full-opening ball type valve to prevent plugging by solids.



DANGER!

If a manual shut-off valve is installed in a bypass line, it must not be left closed during operation. A closed manual shut-off valve may cause a pump which has lost prime to continue to operate without reaching prime, causing dangerous overheating and possible explosive rupture of the pump casing. Personnel could be severely injured.

Allow an over-heated pump to cool before servicing. Do not remove plates, covers, gauges, or fittings from an overheated pump. Liquid within the pump can reach boiling temperatures, and vapor pressure within the pump can cause parts being disengaged to be ejected with great force. After the pump cools, drain the liquid from the pump by removing the casing drain plug. Use caution when removing the plug to prevent injury to personnel from hot liquid.

AUTOMATIC AIR RELEASE VALVE

When properly installed and correctly adjusted to the specific hydraulic operating conditions of the application, the Gator Prime Automatic Air Release Valve will permit air to escape through the bypass line, and then close automatically when the pump is fully primed and pumping at full capacity.

Theory of Operation

Figures 3 and 4 show a cross-sectional view of the Automatic Air Release Valve, and a corresponding description of operation.

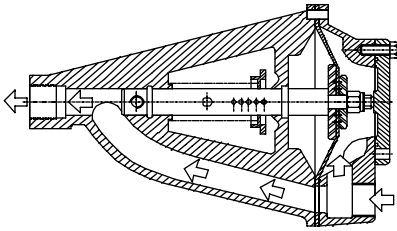

Figure 3. Valve in Open Position

During the priming cycle, air from the pump casing flows through the bypass line, and passes through the Air Release valve to the wet well (Figure 3).

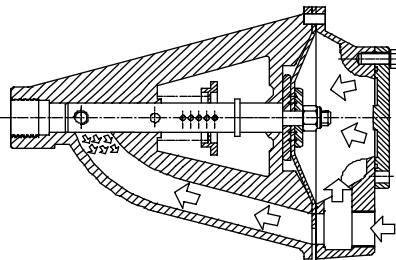

Figure 4. Valve in Closed Position

When the pump is fully primed, pressure resulting from flow against the valve diaphragm compresses the spring and closes the valve (Figure 4).

The valve will remain closed, reducing the bypass of liquid to 1 to 5 gallons (3.8 to 19 liters) per minute, until the pump loses its prime or stops.



WARNING!

Some leakage (1 to 5 gallons [3.8 to 19 liters] per minute) will occur when the valve is fully closed. Be sure the bypass line is directed back to the wet well or tank to prevent hazardous spills.

When the pump shuts down, the spring returns the diaphragm to its original position. Any solids that may have accumulated in the diaphragm chamber settle to the bottom and are flushed out during the next priming cycle.

NOTE

The valve will remain open if the pump does not reach its designed capacity or head. Valve closing pressure is dependent upon the discharge head of the pump at full capacity. The range of the valve closing pressure is established by the tension rate of the spring as ordered from the factory. Valve closing pressure can be further adjusted to the exact system requirements by moving the spring retaining pin up or down the plunger rod to increase or decrease tension on the spring. Contact your Gator Prime distributor or Thomas Pump & Machinery for information about an Automatic Air Release Valve for your specific application.

Air Release Valve installation

The Automatic Air Release Valve must be independently mounted in a horizontal position and connected to the discharge line of the self-priming centrifugal pump (see Figure 5).

NOTE

If the Air Release Valve is to be installed on a staged pump application, contact the factory for specific installation instructions.

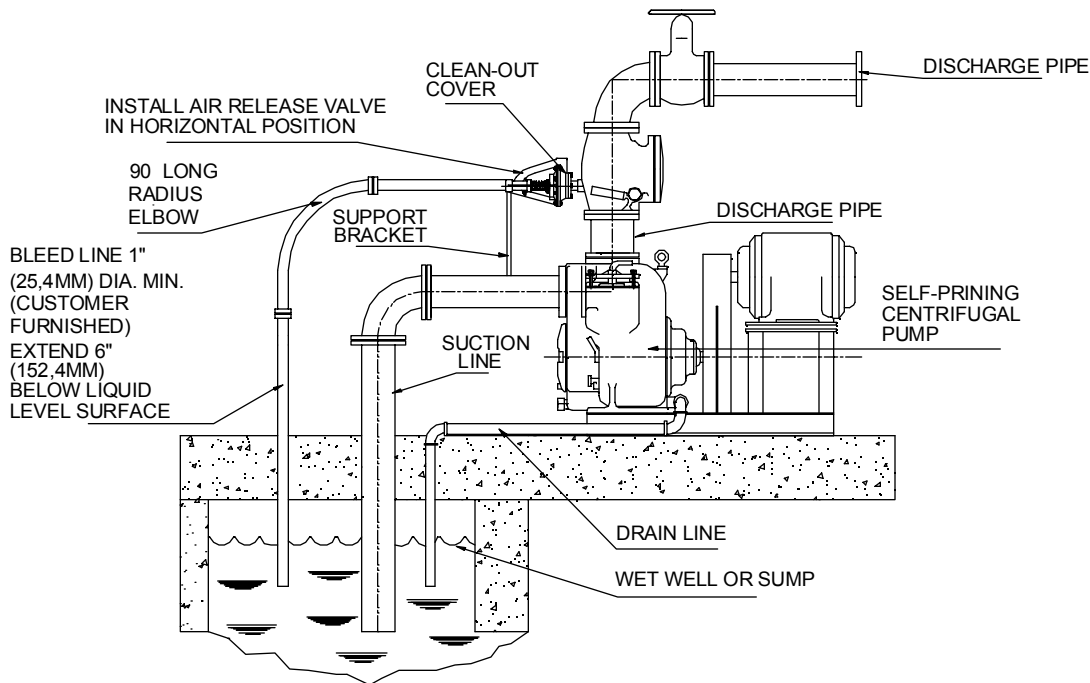

Figure 5. Typical Automatic Air Release Valve Installation

The valve inlet must be installed between the pump discharge port and the non-pressurized side of the discharge check valve. The valve inlet is it at the large end of the valve body, and is provided with standard 1-inch NPT pipe threads.

The valve outlet is located at the opposite end of the valve, and is also equipped with standard 1-inch NPT pipe threads. The outlet should be connected to a bleed line which slopes back to the wet well or sump. The bleed line must be the same size as the inlet piping, or larger. If piping is used for the bleed line, avoid the use of elbows whenever possible.

NOTE

It is recommended that each Air Release Valve be fitted with an independent bleeder line directed back to the wet well. However, if multiple Air Release Valves are installed in a system, the bleeder lines may be directed to a common manifold pipe. Contact your Gator Prime distributor or Thomas Pump & Machinery for information about installation of an Automatic Air Release Valve for your specific application.

ALIGNMENT

The alignment of the pump and its power source is critical for trouble-free mechanical operation. In either a flexible coupling or V-belt driven system, the driver and pump must be mounted so that their shafts are aligned with and parallel to each other. It is imperative that alignment be checked after the pump and piping are installed, and before operation.

NOTE

*Check **Rotation**, Section C, before alignment of the pump.*

When mounted at the Gator Prime factory, driver and pump are aligned before shipment. Misalignment will occur in transit and handling. Pumps must be checking alignment, tighten the foundation bolts. The pump casing feet and/or pedestal feet, and the driver mounting bolts should also be tightly secured.



WARNING!

When checking alignment, disconnect the power source to ensure that the pump will remain inoperative.



CAUTION!

Adjusting the alignment in one direction may alter the alignment in another direction. Check each procedure after altering alignment.

Coupled Drives

When using couplings, the axis of the power source must be aligned the axis of the pump shaft in both the horizontal and vertical planes. Most couplings require a specific gap or clearance between the driving and the driven shafts. Refer to the coupling manufacturer's service literature.

Align spider insert type couplings by using calipers to measure the dimensions on the circumference of the outer ends of the coupling hub every 90 degrees. The coupling is in alignment when the hub ends are the same distance apart at all points (see Figure 6A).

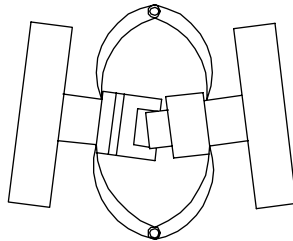

Figure 6A. Aligning Spider – Type Couplings

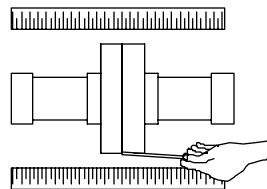
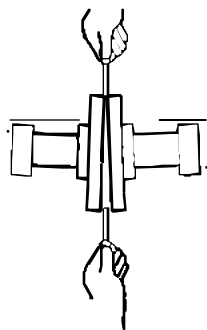

Figure 6B. Aligning Non-Spider Type Couplings

Align non-spider type couplings by using a feeler gauge or taper gauge between the coupling halves every 90 degrees. The coupling is in alignment when the hubs are the same distance apart at all points (see Figure 6B).

Check parallel adjustment by laying a straightedge across both coupling rims at the top, bottom, and side. When the straightedge rests evenly on both halves of the coupling, the coupling is in horizontal parallel alignment. If the coupling is misaligned use a feeler gauge between the coupling and the straightedge to measure the amount of misalignment.

V-Belt Drives

When using V-belt drives, the power source and the pump must be parallel. Use a straightedge along the sides of the pulleys to ensure that the pulleys are properly aligned (see Figure 6C). In drive systems using two or more belts, make certain that the belts are a matched set; unmatched sets will cause accelerated belt wear.

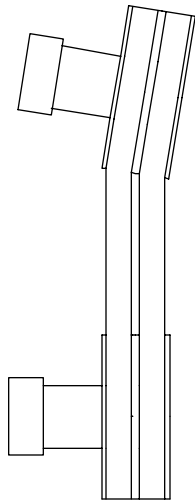

**MISALIGNED: SHAFTS
NOT PARALLEL**

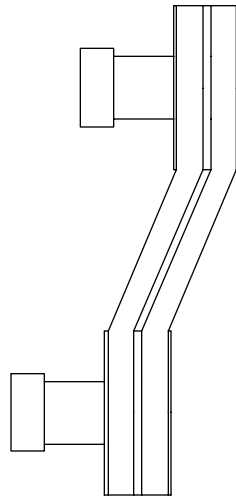

**MISALIGNED: SHAFTS
NOT IN LINE**

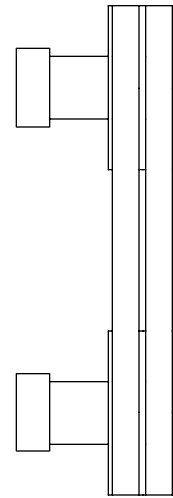

**ALIGNED: SHAFTS PARALLEL
AND SHEAVES IN LINE**

Figure 6C. Alignment of V-Belt Driven Pumps

Tighten the belts in accordance with the belt manufacturer's instructions. If the belts are too loose, they will slip; if the belts are too tight, there will be excessive power loss and possible bearing failure. Select pulleys that will match the proper speed ratio; over speeding the pump may damage both pump and power source.



DANGER!

Do not operate the pump without the guard in place over the rotating parts. Exposed rotating parts can catch clothing, fingers, or tools, causing severe injury to personnel.

OPERATION – SECTION C

Review all SAFETY information in Section A.

Follow instructions on all tags, labels and decals attached to the pump.



WARNING!

This pump is designed to handle mild industrial corrosives, mud or slurries containing large entrained solids. Do not attempt to pump volatile; corrosive, or flammable liquids which may damage the pump or endanger personnel as a result of pump failure.



CAUTION!

Pump speed and operating conditions must be within the performance range shown on page 21.

PRIMING

Install the pump and piping as describe in **INSTALLATION**. Make sure that the piping connections are tight, and that the pump is securely mounted. Check that the pump is properly lubricated (see **LUBRICATION** in **MAINTENANCE AND REPAIR**).

This pump is self-priming, but the pump should never be operated unless there is liquid in the pump casing.



CAUTION!

Never operate this pump unless there is liquid in the pump casing. The pump will not prime when dry. Extend operation of a dry pump will destroy the seal assembly.

Add liquid to the pump casing when:

1. The pump is being put into service for the first time.
2. The pump has not been used for a considerable length of time.
3. The liquid in the pump casing has evaporated.

Once the pump casing has been filled, the pump will prime and reprime as necessary.



WARNING!

After filling the pump casing, reinstall and tighten the fill plug. Do not attempt to operate the pump unless all connecting piping is securely installed. Otherwise, liquid in the pump forced out under pressure could cause injury to personnel.

To fill the pump, remove the pump casing fill cover or fill plug in the top of the casing, and add clean liquid until the casing is filled. Replace the fill cover or fill plug before operating the pump.

STARTING

Consult the operations manual furnished with the power source.

Rotation

The correct direction of pump rotation is counterclockwise when facing the impeller. The pump could be damaged and performance adversely affected by incorrect rotation. If pump performance is not within the specified limits (see the curve on page 21), check the direction of power source rotation before further troubleshooting.

If an electric motor is used to drive the pump, remove V-belts, couplings, or otherwise disconnect the pump from the motor before checking motor rotation. Operate the motor independently while observing the direction of the motor shaft, or cooling fan.

If rotation is incorrect on a three-phase motor, have a qualified electrician interchange any of the Phase wires to change direction. If rotation is incorrect on a single-phase motor, consult the literature supplied with the motor for specific instructions.

OPERATION

Lines With a Bypass

If a Gator Prime Automatic Air Release Valve has been installed, the valve will automatically open to allow the pump to prime, and automatically close after priming is complete (see **INSTALLATION** for Air Release Valve operation).

Lines Without a Bypass

Open all valves in the discharge line and start the power source. Priming is indicated by a positive reading on the discharge pressure gauge or by a quieter operation. The pump may not prime immediately because the suction line must first fill with liquid. If the pump fails to prime within five minutes, stop it and check the suction line for leaks.

After the pump has been primed, partially close the discharge line throttling valve in order to fill the line slowly and guard against excessive shock pressure which could damage pipe ends, gaskets, sprinkler heads, and any other fixtures connected to the line. When the discharge line is completely filled, adjust the throttling valve to the required flow rate.



WARNING!

Do not operate the pump against a closed discharge throttling valve for long periods of time. If operated against a closed discharge throttling valve, pump components will deteriorate, and the liquid could come to a boil, build pressure, and cause the pump casing to rupture or explode.

Leakage

No leakage should be visible at pump mating surfaces, or at pump connections or fittings. Keep all line connections and fittings tight to maintain maximum pump efficiency.

Liquid Temperature And Overheating

The **maximum** liquid temperature for this pump is 160° F(71° C). Do not apply it at a higher operating temperature.

Overheating can occur if operated with the valves in the suction or discharge lines closed. Operating against closed valves could bring the liquid to a boil, build pressure, and cause the pump to rupture or explode. If overheating occurs, stop the pump and allow it to cool before servicing it. Refill the pump casing with cool liquid.



DANGER!

Allow an over-heat pump to cool before servicing. Do not remove plates, covers, gauges, or fittings from an overheated pump. Liquid within the pump can reach boiling temperatures, and vapor pressure within the pump can cause parts being disengaged to be ejected, with great force. After the pump cools, drain the liquid from the pump by removing the casing drain plug. Use caution when removing the plug to prevent injury to personnel from hot liquid.

As safeguard against rupture or explosion due to heat, this pump is equipped with a pressure relief valve which will open if vapor pressure within the pump casing reaches a critical point. If overheating does occur, stop the pump immediately and allow it to cool before servicing it. Approach any overheated pump cautiously. It is recommended that the pressure relief valve assembly be replaced at each overhaul, or any time the pump casing overheats and activates the valve. Never replace this valve with a substitute which has not been specified or provided by Thomas Pump & Machinery.

Strainer Check

If a suction strainer has been shipped with the pump or installed by the user, check the strainer regularly, and clean it as necessary. The strainer should also be checked if pump flow rate begins to drop. If a vacuum suction gauge has been installed, monitor and record the readings regularly to detect strainer blockage.

Never introduce air or steam pressure into the pump casing or piping to remove a blockage. This could result in personal injury or damage to the equipment. If back flushing is absolutely necessary, liquid pressure **must** be limited to 50% of the maximum permissible operating pressure show on the pump performance curve.

Pump Vacuum Check

With the pump inoperative, install a vacuum gauge in the system, using pipe dope on the threads. Block the suction line and start the pump. At operating speed the pump should pull a vacuum of 20 inches (508,0mm) or more of mercury. If it does not, check for air leaks in the seal, gasket, or discharge valve.

Open the suction line, and read the vacuum gauge with the pump primed and at operation speed. Shut off the pump. The vacuum gauge reading will immediately drop proportionate to static suction lift, and should then stabilize. If the vacuum reading falls off rapidly after stabilization, an air leak exists. Before checking for the source of the leak, check the point of installation of the vacuum gauge.

STOPPING

Never halt the flow of liquid suddenly. If the liquid being pumped is stopped abruptly, damaging shock waves can be transmitted to the pump and piping system. Close all connecting valves slowly.

On engine driven pumps, reduce the throttle speed slowly and allow the engine to idle briefly before stopping.



CAUTION!

If the application involves a high discharge head, gradually close the discharge throttling valve before stopping the pump.

After stopping the pump, lock out or disconnect the power source to ensure that the pump will remain inoperative.



WARNING!

Do not operate the pump against a closed discharge throttling valve for long periods of time. If operated against a closed discharge throttling valve, pump components will deteriorate, and the liquid could come to a boil, build pressure, and cause the pump casing to rupture or explode.

Cold Weather Preservation

In below freezing conditions, drain the pump to prevent damage from freezing. Also, clean out any solids by flushing with a hose. Operate the pump for approximately one minute; this will remove any remaining liquid that could freeze the pump rotating parts. If the pump will be idle for more than a few hours, or if it has been pumping liquids containing a large amount of solids, drain the pump, and flush it thoroughly with clean water. To prevent large solids from clogging the drain port and preventing the pump from completely draining, insert a rod or stiff wire in the drain port, and agitate the liquid during the draining process. Clean out any remaining solids by flushing with a hose.

BEARING TEMPERATURE CHECK

Bearings normally run at higher than ambient temperatures because of heat generated by friction. Temperatures up to 160° F(71° C) are considered normal for bearings, and they can operate safely to at least 180° F(82° C).

Checking bearing temperatures by hand is inaccurate. Bearing temperatures can be measured accurately by placing a contact-type Thermometer against the housing. Record this temperature for future reference.

A sudden increase in bearing temperature is a warning that the bearings are at the point of failing to operate properly. Make certain that the bearing lubricant is of the proper viscosity and at the correct level (see **LUBRICATION** in **MAINTENANCE AND REPAIR**).

Bearing overheating can also be caused by shaft misalignment and/or excessive vibration.

When pumps are first started, the bearings may seem to run at temperatures above normal. Continued operation should bring the temperatures down to normal levels.

TROUBLESHOOTING - SECTION D

Review all SAFETY information in Section A.



Before attempting to open or service the pump:

1. Familiarize yourself with this manual.
2. Lock out or disconnect the power source to ensure that the pump will remain inoperative.
3. Allow the pump to cool if overheated.
4. Check the temperature before opening any covers, plates, or plugs.
5. Close the suction and discharge valves.
6. Vent the pump slowly and cautiously.
7. Drain the pump.

TROUBLE	POSSIBLE CAUSE	PROBABLE REMEDY
PUMP FAILS TO PRIME	Not enough liquid in casing.	Add liquid to casing. See PRIMING .
	Suction check valve contaminated or damaged.	Clean or replace check valve.
	Air leak in suction line.	Correct leak.
	Lining of suction hose collapsed.	Replace suction Hose.
	Leaking or worn seal or pump gasket.	Check pump vacuum. Replace leaking Or worn seal or gasket.
	Suction lift or discharge head too high.	Check piping installation and install bypass line if needed. See INSTALLATION .
	Strainer clogged.	Check strainer and clean if necessary.

TROUBLE	POSSIBLE CAUSE	PROBABLE REMEDY
PUMP STOPS OR FAILS TO DELIVER RATED FLOW OR PRESSURE	<p>Air leak in suction line.</p> <p>Lining of suction hose collapsed.</p> <p>Leaking or worn seal or pump gasket.</p> <p>Strainer clogged.</p> <p>Suction intake not submerged at proper level or sump too small.</p> <p>Impeller or other wearing parts worn or damaged.</p> <p>Impeller clogged.</p> <p>Pump speed too slow.</p> <p>Discharge head too high.</p> <p>Suction lift too high.</p>	<p>Correct leak.</p> <p>Replace suction hose.</p> <p>Check pump vacuum. Replace leaking or worn seal or gasket.</p> <p>Check strainer and clean if necessary.</p> <p>Check installation and correct submergence as needed.</p> <p>Replace worn or damaged parts. Check that impeller is properly centered and rotates.</p> <p>Free impeller of debris.</p> <p>Check driver output; check belts or couplings for slippage.</p> <p>Install bypass line.</p> <p>Measure lift w/vacuum gauge. Reduce lift and/or friction losses in suction line.</p>
PUMP REQUIRES TOO MUCH POWER	<p>Pump speed too high</p> <p>Discharge head too low.</p> <p>Liquid solution too thick.</p> <p>Bearing(s) frozen.</p>	<p>Check driver output; check that sheaves or motor rpm are correctly sized.</p> <p>Adjust discharge valve.</p> <p>Dilute if possible.</p> <p>Disassemble pump and check bearing(s).</p>
PUMP CLOGS FREQUENTLY	<p>Liquid solution too thick.</p> <p>Discharge flow too slow.</p> <p>Suction check valve or foot valve Clogged or binding.</p>	<p>Dilute if possible.</p> <p>Open discharge valve fully to increase flow rate, and run power source at maximum governed speed.</p> <p>Clean valve.</p>

TROUBLE	POSSIBLE CAUSE	PROBABLE REMEDY
EXCESSIVE NOISE	Cavitation in pump. Pumping entrained air. Pump or drive not securely mounted. Impeller clogged or damaged.	Reduce suction lift and/or friction losses in suction line. Record vacuum and pressure gauge readings and consult local representative or factory. Locate and eliminate source of air bubble. Secure mounting hardware. Clean out debris; replace damaged parts.
BEARINGS RUN TOO HOT	Bearing temperature is high, but within limits. Low or incorrect lubricant. Suction and discharge lines not properly Supported. Drive misaligned.	Check bearing temperature regularly to Monitor any increase. Check for proper type and level of lubricant. Check piping installation for proper support. Align drive properly.

PUMP MAINTENANCE AND REPAIR – SECTION E

MAINTENANCE AND REPAIR OF THE WEARING PARTS OF THE PUMP
WILL MAINTAIN PEAK OPERATING PERFORMANCE.

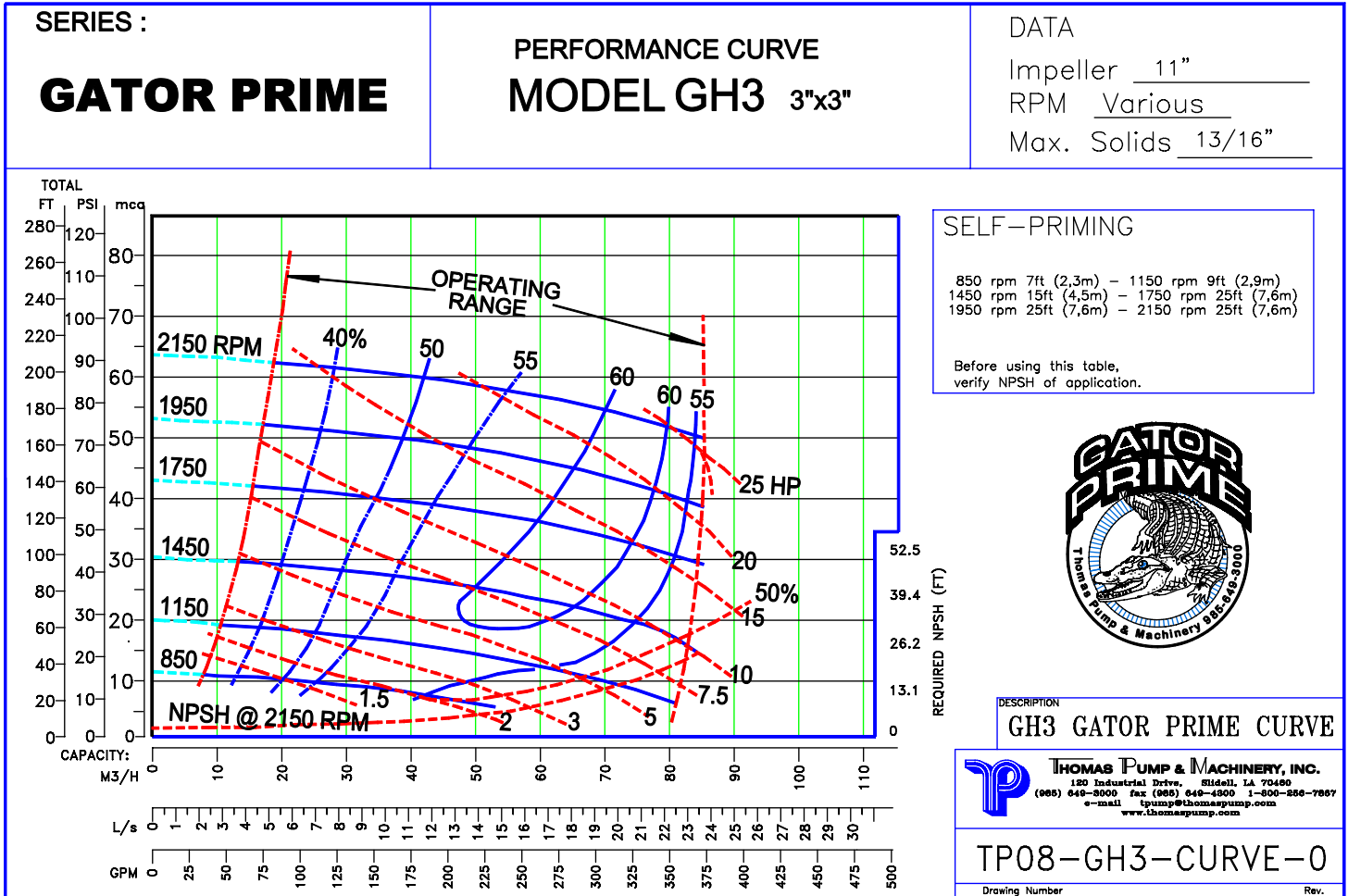

STANDARD PERFORMANCE FOR PUMP MODEL GH - 3

Based on 70° F(21° C) clear water at sea level with minimum suction lift. Since pump installations are seldom identical, your performance may be difference due to such factors as viscosity, specific gravity, elevation, temperature, and impeller trim.

↓ CAUTION!

Pump speed and operating condition points must be within the continuous performance range shown on the curve.

SECTION DRAWING

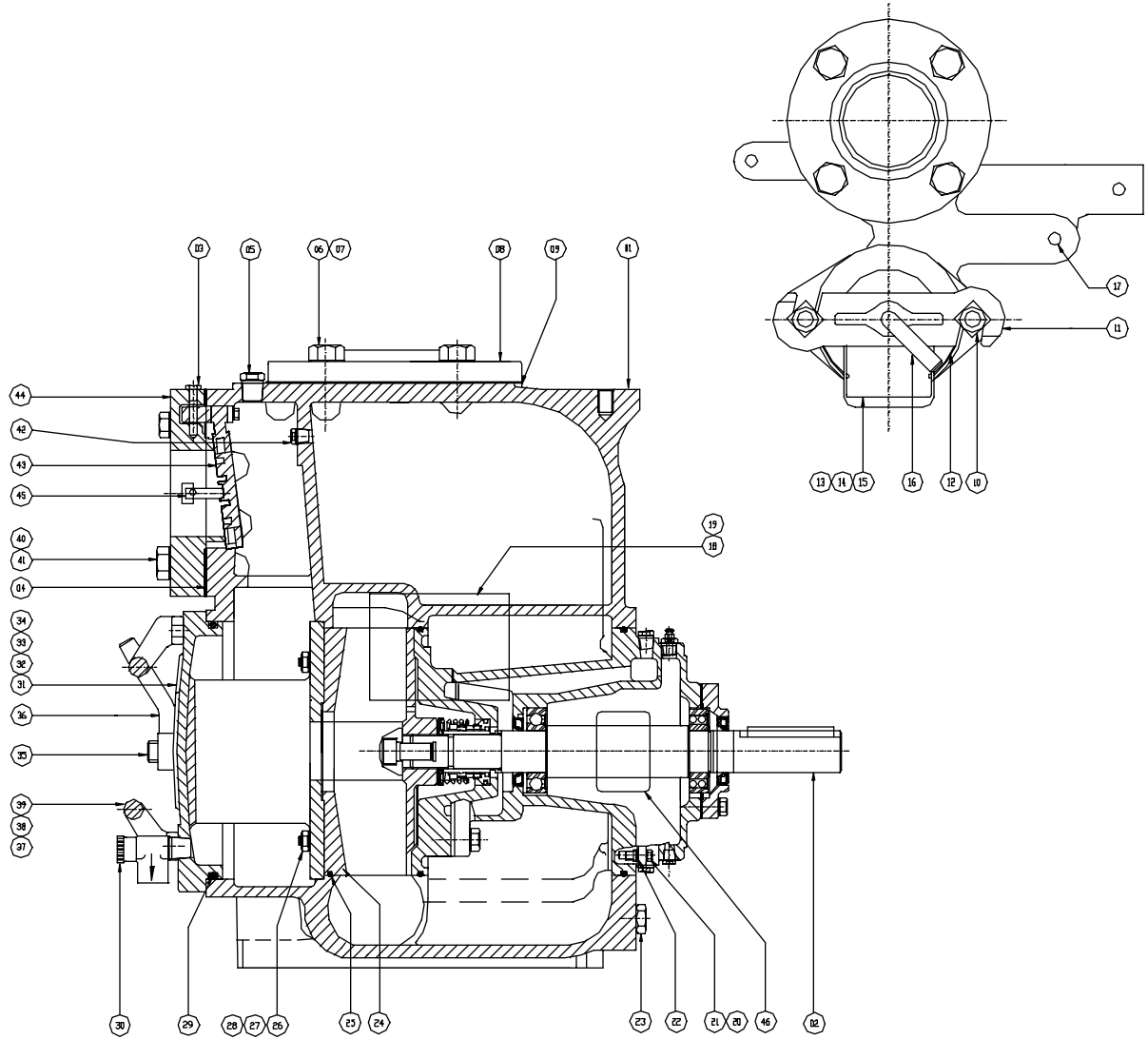

Figure 1. Pump Model

PARTS LIST

Pump Model GH - 3

ITEM NO.		PART NAME	QTY	PART NUMBER
01		PUMP CASING	01	9600134000
02	*	REPAIR ROTATING ASSY	01	9600150000
03		CHECK VALVE PIN	01	9901349000
04	*	SUCT CHK VALVE ASSY	01	9901348000
05		PIPE PLUG	01	3310271020
06		HEX HD CAPSCREW	04	2101265080
07		LOCKWASHER	04	2321080880
08		DISCHARGE FLANGE	01	3354211140
09	*	DISCH FLANGE GSTK	01	9901344000
10		MACHINE BOLT	02	2102565150
11		CLAMP BAR	01	9800868000
12	*	FILL COVER GASKET	01	9901330000
13		FILL COVER ASSY	01	9901299000
14		WARNING PLATE	01	9901331000
15		DRIVE SCREW	02	2750201200
16		CLAMP BAR SCREW	01	9901311000
17		PIPE PLUG	01	3310271020
18		NAME PLATE	01	9901326000
19		DRIVE SCREW	04	2750201200
20		HEX HD CAPSCREW	04	2101263890
21		LOCKWASHER	04	2321080840
22		ROT ASSY SCREW SET	04	2102133870
23		VENTED PLUG	01	9901372000
24		WEAR PLATE ASSY	01	9700505000
25	*	BACK COVER O'RING	01	3606222760
26		STUD	04	9901426000
27		HEX NUT	04	2211270020
28		LOCKWASHER	02	2321081360
29	*	BACK COVER O-RING	01	3606222760
30		PRESS RELIEF VALVE	01	6768500300
31		BACK COVER PLATE ASSY	01	9700486000
32		WARNING PLATE	01	9901328000
33		DRIVE SCREW	04	2750201200
34		CAUTION DECAL	01	9901329000
35		STUD	01	9901347000
36		HAND NUT	01	9901345000
37		BACK COVER PLATE	01	9800887000
38		HEX HD CAPSCREW	04	2101262570
39		LOCKWASHER	04	2321090800
40		LOCKWASHER	04	2321080880
41		HEX HD CAPSCREW	04	2101265100
42		PIPE PLUG	01	3310271020
43	*	VALVE ASSEMBLY	01	9700465000
44		SUCTION FLANGE	01	9901343000
45		PIPE PLUG	01	3310271020
46		WARNING DECAL	01	9901433000

* INDICATES PARTS RECOMMENDED FOR STOCK

SECTION DRAWING

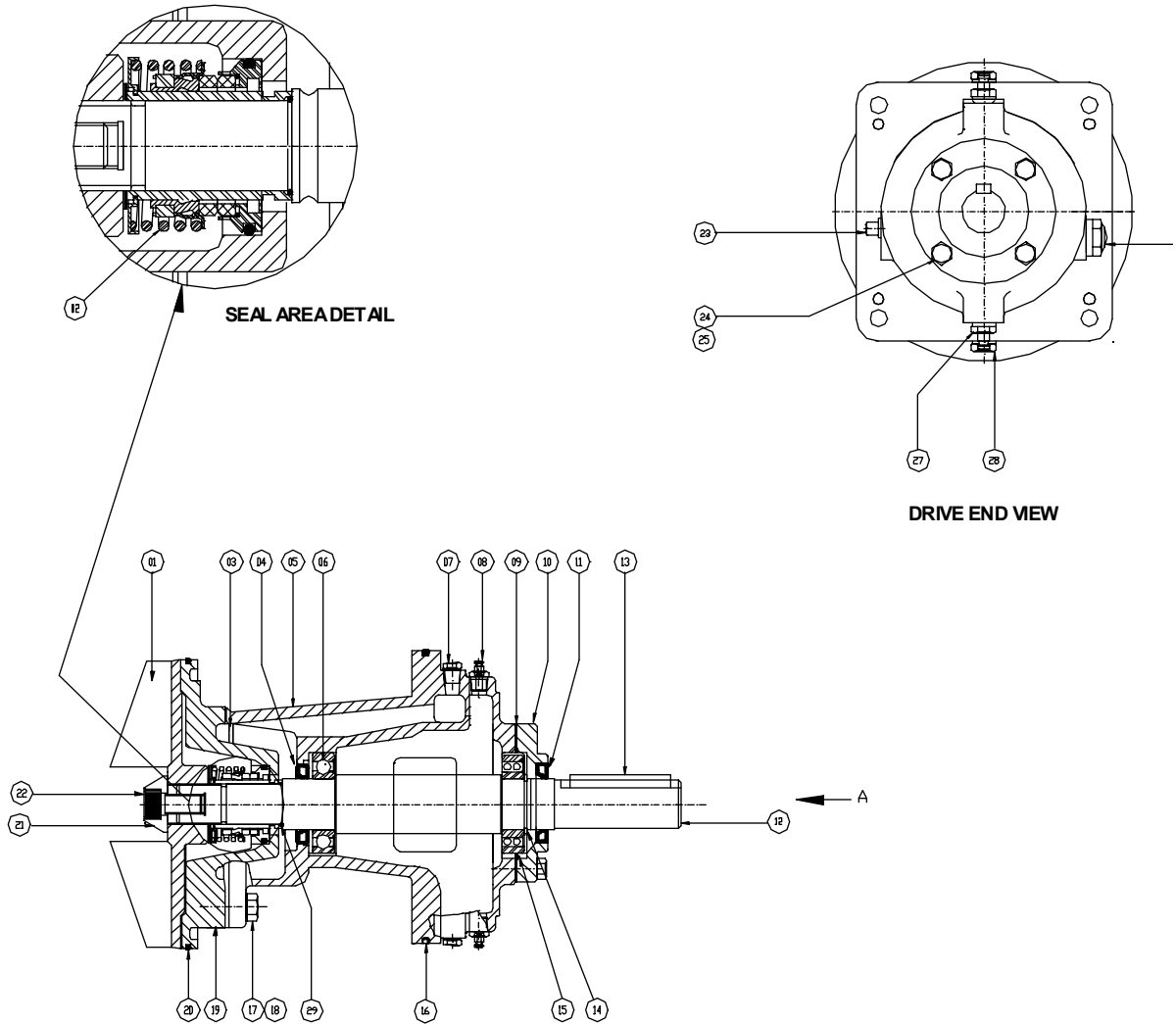

Figure 2. Repair Rotating Assembly

PART LIST

Repair Rotating Assembly

ITEM NO.	PART NAME	QTY	PART NUMBER
01	* IMPELLER	01	9700487000
02	* SEAL ASSEMBLY	01	9800906000
03	* SEAL PLATE GASKET	01	9901333000
04	* INBOARD OIL SEAL	01	3680047800
05	BEARING HOUSE	01	9700485000
06	INBOARD BALL BEARING	01	3180012060
07	VENTED PLUG	01	9901335000
08	AIR VENT	01	3310990600
09	* BEARING CAP GASKET	01	9901337000
10	BEARING CAP	01	9800870000
11	* BEARING CAP OIL SEAL	01	3680047800
12	IMPELLER SHAFT	01	9800905000
13	* SHAFT KEY	01	9901351000
14	BEARING RETAINING RING	01	3921501041
15	OUTBOARD BALL BEARING	01	3180074380
16	* ROTATING ASSY O-RING	01	3606130690
17	HEX HD CAPSCREW	04	2101263890
18	LOCKWASHER	04	2321080840
19	SEAL PLATE	01	9700488000
20	* SEAL PLATE O-RING	01	3606222760
21	IMPELLER WASHER	01	9901371000
22	SOCKET HD CAPSCREW	01	2102141950
23	PIPE PLUG	01	3310271080
24	HEX HD CAPSCREW	04	2101262580
25	LOCKWASHER	04	2321080800
26	SIGHT GAUGE	01	3480500200
27	PIPE PLUG	01	3310271080
28	PIPE PLUG	01	3310271080
29	SEAL PLATE O-RING	01	3606220240

* INDICATES PARTS RECOMMENDED FOR STOCK

PUMP AND SEAL DISASSEMBLY AND REASSEMBLY

Review all SAFETY Information in Section A.

Follow the instructions on all tags, label and decals attached to the pump.

This pump requires little service due to its rugged, minimum-maintenance design. However, if it becomes necessary to inspect or replace the wearing parts, follow these instructions which are keyed to the sectional views (see Figures 1 and 2) and the accompanying parts lists.

Many service functions may be performed by draining the pump and removing the back cover assembly. If major repair is required, the piping and/or power source must be disconnected. The following instructions assume complete disassembly is required.

Before attempting to service the pump, disconnect or lock out the power source and take precautions to ensure that it will remain inoperative. Close all valves in the suction and discharge lines.

For power source disassembly and repair, consult the literature supplied with the power source, or contact your local power source representative.



WARNING!

Before attempting to open or service the pump:

1. Familiarize yourself with this manual.
2. Disconnect or lock out the power source to ensure that the pump will remain inoperative.
3. Allow the pump to cool if overheated.
4. Check the temperature before opening any covers, plates, or plugs.
5. Close the suction and discharge valves.
6. Vent the pump slowly and cautiously.
7. Drain the pump.



WARNING!

Use lifting and moving equipment in good repair and with adequate capacity to prevent injuries to personnel or damage to equipment.

Back Cover And Wear Plate Removal

(Figure 1)

The wear plate (24) is easily accessible and may be serviced by removing the back cover assembly (31). Before attempting to service the pump, remove the pump casing drain plug (23) and drain the pump. Clean and reinstall the drain plug.

Remove the hand nuts (36) and pull the back cover and assembled wear plate from the pump casing (1). Inspect the wear plate, and replace it if badly scored or worn. To remove the wear plate, disengage the hardware (27).

Inspect the back cover O-ring (29) and replace it if damaged or worn.

Suction Check Valve Removal

(Figure 1)

If the check valve assembly (43) is to be serviced, remove the check valve pin (03), reach through the back cover opening and pull the complete assembly from the suction flange.

NOTE

Further disassembly of the check valve is not required since it must be replaced as a complete unit. Individual parts are not sold separately.

Rotating Assembly Removal

(Figure 2)

The rotating assembly (Figure 2) may be serviced without disconnecting the suction or discharge piping; however, the power source must be removed to provide clearance.

The impeller (01) should be loosened while the rotating assembly is still secured to the pump casing. Before loosening the impeller, remove the seal cavity drain plug (28) and drain the seal lubricant. This will prevent the oil in the seal cavity from escaping when the impeller is loosened. Clean and reinstall the seal cavity drain plug.

Immobilize the impeller by wedging a block wood between the vanes and the pump casing, and remove the impeller capscrew and washer (21 and 22).

Install a lathe dog on the drive end of the shaft (12, see Figure 3) with the "V" notch positioned over the shaft keyway.

With the impeller rotation still blocked, see Figure 3 and use a long piece of heavy bar stock to pry against the arm of the lathe dog in a counterclockwise direction (when facing the drive end of the shaft). **Use caution** not to damage the shaft or keyway. When the impeller breaks loose, remove the lathe dog and wood block.

NOTE

Do not remove the impeller until the rotating assembly has been removed from the pump casing.

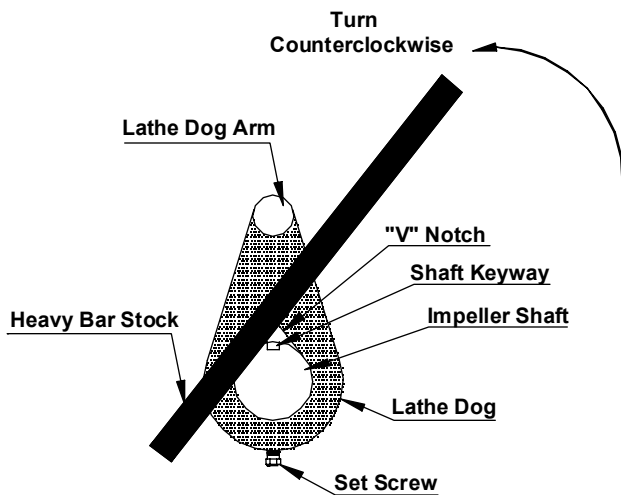

Figure 3. Loosening impeller

(Figure 1)

Remove the hardware (21 and 22) securing the rotating assembly to the pump casing. Separate the Rotating assembly by pulling straight away from the pump casing.

NOTE

An optional disassembly tool is available from the factory. If the tool is used, follow the instructions packed with it. A similar tool may be assembled using 1/2 inch pipe (schedule 80 steel or malleable iron) and a standard tee (see Figure 4).All threads are 1/2 inch NPT. Do not pre-assemble the tool.

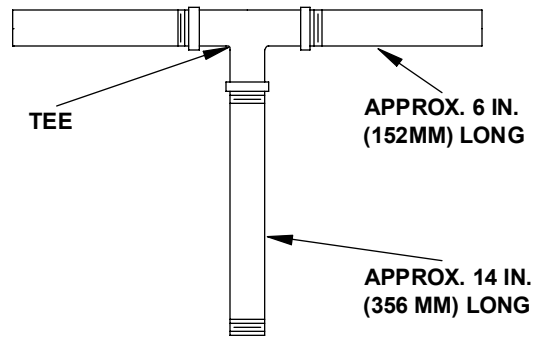

Figure 4. Rotating Assembly Tool

To install the tool, remove the air vent (8, Figure 2) from the bearing housing, and screw the longest length of pipe into the vent hole until fully engaged. Install the tee, and screw the handles into the tee. Use caution when lifting the rotating assembly to avoid injury to personnel or damage to the assembly.

Remove the bearing housing (05) and seal plate O-rings (16 and 20).

Impeller Removal

(Figure 2)

With the rotating assembly removed from the pump casing, unscrew the impeller from the shaft. Use caution when unscrewing the impeller; tension on the shaft seal spring will be released as the impeller is removed. Inspect the impeller and replace if cracked or badly worn.

Remove the impeller adjusting shims tie and tag the shims, or measure and record their thickness for ease of reassembly.

Seal Removal

(Figure 2)

Slide the integral shaft sleeve and rotating portion of the seal off the shaft as unit.

Use a pair of stiff wires with hooked ends to remove the stationary element and seat.

An alternate method of removing the stationary seal components is to remove the hardware and separate the seal plate (19) and gasket (03) from the bearing housing (05). Position the seal plate on a flat surface with the impeller side down. Use a wooden dowel or other suitable tool to press on the back side of the stationary seat until the seat, O-rings, and stationary element can be removed.

Remove the shaft sleeve O-ring .

If no further disassembly is required, refer to **seal installation**.

Shaft and Bearing Removal and Disassembly

(Figure 2)

When the pump is properly operated and maintenance, the bearing housing should not require disassembly. Disassemble the shaft and bearings only when there is evidence of wear or damage.

⬇ CAUTION!

Shaft and bearing disassembly in the field is not recommended. These operations should be performed only in a properly equipped shop by qualified personnel.

Remove the bearing housing drain plug (08) and drain the lubricant. Clean and reinstall the drain plug.

Disengage the hardware (24 and 25) and slide the bearing cap (10) and oil seal (11) off the shaft. Remove the bearing cap gasket (09), and press the oil seal from the bearing cap.

Place a block of wood against the impeller end of the shaft and tap the shaft and assembled bearings from the bearing housing.

After removing the shaft and bearings, clean and inspect the bearings **in place** as follows.

⬇ CAUTION!

To prevent damage during removal from the shaft, it is recommended that bearings be cleaned and inspected in place. It is strongly recommended that the bearings be replaced any time the shaft and bearings are removed.

Clean the bearing housing, shaft and all component parts (except the bearings) with a soft cloth soaked in cleaning solvent. Inspect the parts for wear or damage and replace as necessary.

⬇ WARNING!

Most cleaning solvents are toxic and flammable. Use them only in a well-ventilated area free from excessive heat, sparks, and flame. Read and follow all precautions printed on solvent containers.

Clean the bearings thoroughly in fresh cleaning solvent. Dry the bearings with filtered compressed air and coat with light oil.

⬇ CAUTION!

Bearings must be kept free of all dirt and foreign material. Failure to do so will greatly shorten bearing life. **DO NOT** spin dry bearings. This may scratch the balls or races and cause premature bearing failure.

Rotate the bearings by hand to check for roughness or binding and inspect the bearings balls. If rotation is rough or the bearing balls are discolored, replace the bearings.

The bearing tolerances provide a tight press fit onto the shaft and a snug slip fit into the bearing housing. Replace the bearings, shaft, or bearing housing if the proper bearing fit is not achieved.

If bearing replacement is required, remove the outboard bearing retaining ring (14), and use a bearing puller to remove the bearings from the shaft.

Press the inboard oil seal (04) from the bearing housing.

Shaft and Bearing Reassembly and installation

(Figure 2)

Clean the bearing housing, shaft and all component parts (except the bearings) with a soft cloth soaked in cleaning solvent. Inspect the parts for wear or damage as necessary.

↓ WARNING!

Most cleaning solvents are toxic and flammable. Use them only in a well-ventilated area free from excessive heat, sparks, and flame. Read and follow all precautions printed on solvent containers.

Inspect the shaft for distortion, nicks or scratches, or for thread damage on the impeller end. Dress small nicks and burrs with a fine file or emery cloth. Replace the shaft if defective.

Position the inboard oil seal (04) in the bearing housing bore with the lip positioned as shown in figure 2. Press the oil seal into the housing until the face is just flush with the machined surface on the housing.

↓ CAUTION!

To prevent damage during removal from the shaft, it is recommended that bearings be cleaned and inspected **in place**. It is **strongly** recommended that the bearings be replaced **any** time the shaft and bearings are removed.

NOTE

Position the inboard bearing (06) on the shaft with the shielded side toward the impeller end of the shaft. Position the outboard bearing (15) on the shaft with the integral retaining ring on the bearing O.D. toward the drive end of the shaft.

The bearings may be heated to ease installation. No induction heater, hot oil bath, electric oven, or hot plate may be used to heat the bearings. Bearings should **never** be heated with a direct flame or directly on a hot plate.

NOTE

*If a hot oil bath is used to heat the bearings, both the oil and the container must be **absolutely** clean. If the oil has been previously used, it must be **thoroughly** filtered.*

Heat the bearings to a uniform temperature no **higher than** 250 ° F (120° C), and slide the bearings onto the shaft, one at a time, until they are fully seated. This should be done quickly, in one continuous motion, to prevent the bearings from cooling and sticking on the shaft.

After the bearings have been installed and allowed to cool, check to ensure that they have not moved away from the shaft shoulders in shrinking. If movement has occurred, use a suitable sized sleeve and a press to reposition the bearings against the shaft shoulders.

If heating the bearings is not practical, use a suitable sized sleeve, and an arbor (or hydraulic) press to install the bearings on the shaft.

↓ CAUTION!

When installing the bearings onto the shaft, **never** press or hit against the outer race, ball, or ball cage. Press **only** on the inner race.

Secure the outboard bearing on the shaft with the bearing retaining ring (14).

Slide the shaft and assembled bearings into the bearing housing until the retaining ring on the outboard bearing seats against the bearing housing.

↓ CAUTION!

When installing the shaft and bearings into the bearing bore, push against the outer race. **Never** hit the balls or ball cage.

Press the outboard oil seal (11) into the bearing cap (10) with the lip positioned as shown in figure 2. Replace the bearing cap gasket (09), and secure the bearing cap with the hardware (24 and 25). **Be careful** not to damage the oil seal lip on the shaft keyway.

Lubricate the bearing housing as indicated in **LUBRICATION**.

Seal Installation

(Figures 2,5,6 and 7)

↓ **WARNING!**

Most cleaning solvents are toxic and flammable. Use them only in a well-ventilated area free from excessive heat, sparks, and flame. Read and follow all precautions printed on solvent containers.

Clean the seal cavity and shaft with a cloth soaked in fresh cleaning solvent. Inspect the stationary seat bore in the seal plate for dirt, nicks and burrs, and

remove any that exist. The stationary seat bore **must** be completely clean before installing the seal.

↓ **CAUTION!**

A new seal assembly should be installed **any time** the old seal is removed from the pump. Wear patterns on the finished faces cannot be realigned during reassembly. Reusing an old seal could result in premature failure.

To ease installation of the seal, lubricate the shaft sleeve O-ring and the external stationary seat O-ring with a very small amount of light lubricating oil. See Figure 5 for seal part identification.

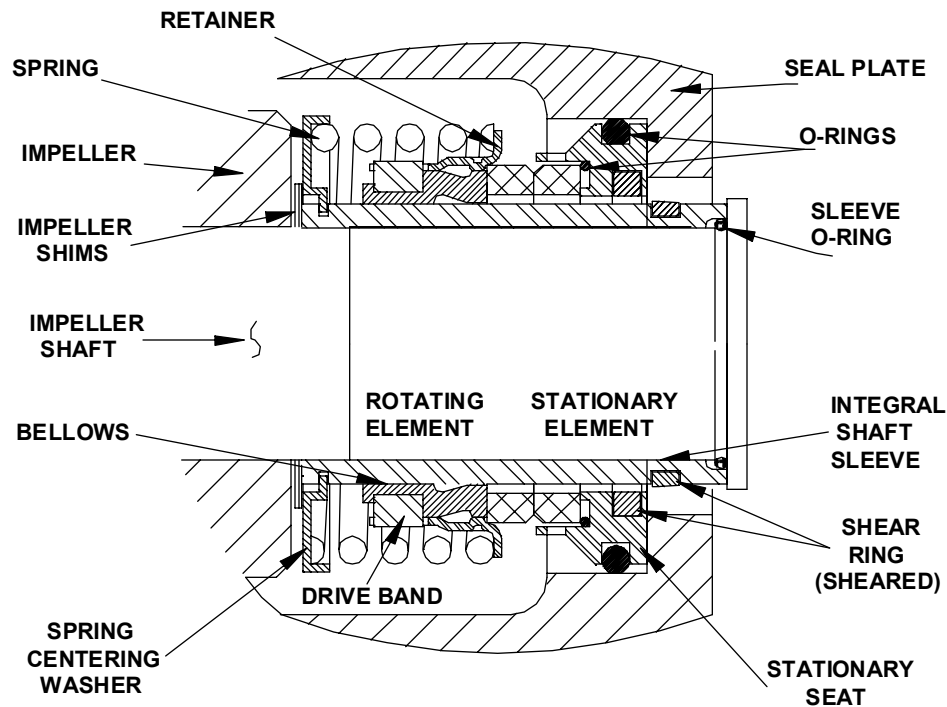

Figure 5. Cartridge Seal Assembly

↓ **CAUTION!**

This seal is not designed for operation at temperatures above 160 ° F (71° C). Do not use at higher operating temperatures.

If the seal plate was removed, install the seal plate gasket (03, figure 2). Position the seal plate over the shaft and secure it to the bearing housing with the hardware (17).

To prevent damaging the shaft sleeve O-ring on the shaft threads, stretch the O-ring over a piece of tubing 1-1/4 I.D. x 1-1/2 O.D x 2 inches long (32mm x 38mm x 51mm).

Slide the tube over the shaft threads, then slide the O-ring off the and onto the shaft. Remove the tube, and continue to slide the O-ring down the shaft until it seats against the shaft shoulder.

When installing a new cartridge seal assembly, remove the seal from the container, and remove the mylar storage tabs from between the seal faces.

↓ **CAUTION!**

New cartridge seal assemblies are equipped with mylar storage tabs between the seal faces. These storage tabs must be removed before installing the seal.

Lubricate the external stationary seat O-ring with light oil. Slide the seal assembly onto the shaft until the external stationary seat O-ring engages the bore in the seal plate.

Clean and inspect the impeller as described in **Impeller Installation and Adjustment**. Install the full set of impeller shims provided with the seal, and screw the impeller onto the shaft until it is seated against the seal (see Figure 6).

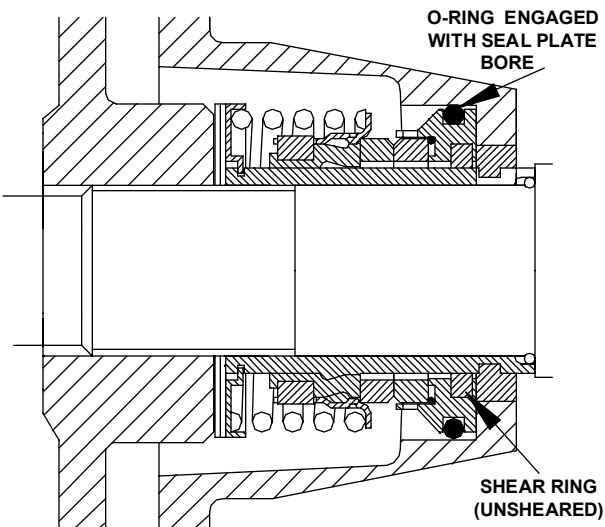

Figure 6. Seal Partially Installed

Continue to screw the impeller onto shaft. This will press the stationary seat into the seal plate bore.

NOTE

A firm resistance will be felt as the impeller presses the stationary seat into the seal plate bore.

As the stationary seat becomes fully seated, the seal spring compresses, and the shaft sleeve will break the nylon shear ring. This allows the sleeve to slide down the shaft until seated against the shaft shoulder. Continue to screw the impeller onto the shaft until the impeller, shims, and sleeve are fully seated against the shaft shoulder (see Figure 7).

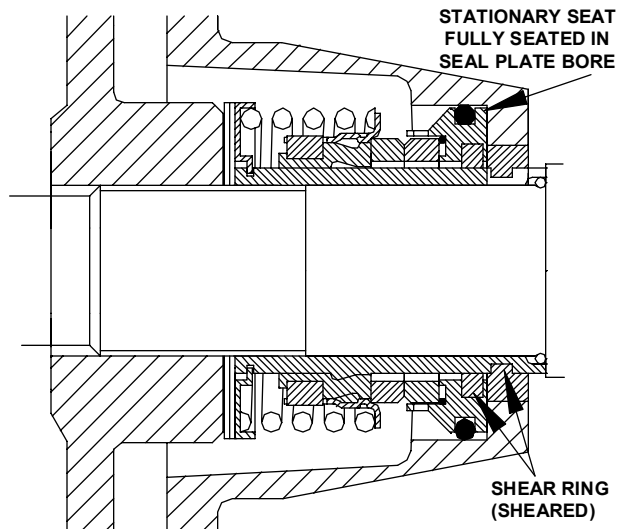

Figure 7. Seal Fully Installed

Measure the impeller-to-seal plate clearance, and remove impeller adjusting shims to obtain the proper clearance as described in **Impeller Installation and Adjustment**.

If necessary to reuse an old seal in an emergency, carefully separate the rotating and stationary seal faces from the bellows retainer and stationary seat.

↓ **CAUTION!**

A new seal assembly should be installed **any time** the old seal is removed from the pump. Wear patterns on the finished reassembly. Reusing an old seal could result in premature failure.

Handle the seal parts with extreme care to prevent damage. Be careful not to contaminate precision finished faces; even fingerprints on the faces with a non-oil based solvent and a clean, lint-free tissue. Wipe **lightly** in a concentric pattern to avoid scratching the faces.

Carefully wash all metallic parts in fresh cleaning solvent and allow to dry thoroughly.



CAUTION!

Do not attempt to separate the rotating portion of the seal from the shaft sleeve when reusing an old seal. The rubber bellows will adhere to the sleeve during use, and attempting to separate them could damage the bellows.

Inspect the seal components for wear, scoring, grooves, and other damage that might cause leakage. Inspect the integral shaft sleeve for nicks or cuts on either end. If any components are worn, or the sleeve is damaged, replace the complete seal; **never mix old and new seal parts.**

Install the stationary seal element in the stationary seat. Press this stationary subassembly into the seal plate bore until it seats squarely against the bore shoulder. A push tube made from a piece of plastic pipe would aid this installation. The I.D. of the pipe should be slightly larger than the O.D. of the shaft sleeve.

Slide the rotating portion of the seal (consisting of the integral shaft sleeve, spring centering washer, spring, bellows and retainer, and rotating element) onto the shaft until the seal faces contact.

Proceed with **Impeller Installation** and **Adjustment.**

Impeller Installation

(Figure 2)

Inspect the impeller, and replace it if cracked or badly worn. Inspect the impeller and shaft threads for dirt or damage, and clean or dress the threads as required.



CAUTION!

The shaft and impeller threads must be completely clean before reinstalling the impeller. Even the slightest amount of dirt on the threads can cause the impeller to seize to the shaft, making future removal difficult or impossible without damage to the impeller or shaft.

Install the same thickness of impeller adjusting shims as previously removed. Apply Never-Seez[®] or equivalent to the shaft threads and screw the impeller onto the shaft until tight. Be sure the seal spring seats squarely over the shoulder on the back side of the impeller.

NOTE

At the slightest sign of binding, immediately back the impeller off, and check the threads for dirt. Do not try to force the impeller onto the shaft.

A clearance of .025 to .040 inch (0,60 to 1,00mm) Between the impeller and the seal plate is recommended for maximum pump efficiency. Measure this clearance, and add or remove impeller adjusting shims as required.

NOTE

If the rotating assembly has been installed in the pump casing, this clearance may be measured by reaching through the priming port with a feeler gauge.

NOTE

Proceed with Rotating Assembly Installation before installing the impeller capscrew and washer (21 and 22). The rotating assembly must be installed in the pump casing in order to torque the impeller capscrew.

After the rotating assembly is installed in the pump casing, coat the threads of the impeller capscrew (22) with 'Never-Seez' or equivalent compound, and install the impeller washer (21) and capscrew; torque the capscrew to 90 ft. lbs. (1080 in.lbs. or 12,4 m.kg.)

Rotating Assembly Installation

(Figure 2)

NOTE

If the pump has been completely disassembled, it is recommended that the suction check valve and back cover assembly be reinstalled at this point. The back cover assembly must be in place to adjust the impeller face clearance.

Install the bearing housing and seal plate O-rings and lubricate them with light grease. Ease the rotating assembly into the pump casing using the installation tool. **Be careful** no to damage the O-rings.

Install the four screw sets of rotating assembly adjusting screw (22) using the same thickness as previously removed. Secure the rotating assembly to the pump casing with the hardware (20 and 21). Do not fully tighten the capscrew until the back cover has been set.

A clearance of .010 to .020 inch (0,25 to 0,51mm) between the impeller and the wear plate is also recommended for maximum pump efficiency. This clearance can be obtained by adjust an equal of screw from each rotating assembly screw set until the impeller scrapes against the wear plate when the shaft is turned. After the impeller scrapes, adjust approximately .015 inch (0,4mm) of clearence with the screw set.

NOTE

An alternate method of adjusting this clearance is to reach through the suction port with a feeler gauge and measure the gap. Adjust rotating assembly screw accordingly.

Suction Check Valve Installation

(Figure 1)

Inspect the check valve assembly (43), and replace it if badly worn.

NOTE

The check valve assembly must be replaced as a complete unit. Individual parts are not sold separately.

Reach through the back cover opening with the check valve (43), and position the check valve adaptor in the mounting slot in the suction flange (44). Align the adaptor with the flange hole, and secure the assembly with the check valve pin (03).

NOTE

If the suction or discharge flanges were removed, replace the respective gaskets, apply 'Permatex Aviation No 3 Form-A-Gasket' or equivalent compound to the mating surfaces, and secure them to the pump casing with the attaching hardware.

Back cover Installation

(Figure 1)

If the wear plate (24) was removed for replacement, carefully center it on the back cover and secure it with the hardware (27 and 28). The wear plate must be concentric to prevent binding when the back cover is installed.

Replace the back cover O-ring (29), and lubricate it with a generous amount of No.2 grease. Clean any scale or debris from the contacting surfaces in the pump casing that might interfere or prevent a good seal with the back cover. Slide the back cover assembly into the pump casing. Be sure the wear plate does not bind against the impeller.

NOTE

To ease future disassembly, apply a film of grease or Never-Seez' on the back cover shoulder, or any surface which contacts the pump casing. This action will reduce rust and scale build-up.

Secure the back cover assembly by tightening the hand nuts (36) evenly. **Do not** over-tighten the hand nuts; they should be just tight enough to ensure a good seal at the back cover shoulder. Be sure the wear plate does not bind against the casing.

PRESSURE RELIEF VALVE MAINTENANCE

(Figure 1)

The back cover is equipped with a pressure relief valve (30) to provide additional safety for the pump and operator (refer to **Liquid Temperature And Overheating in OPERATION**).

It is recommended that the pressure relief valve assembly be replaced at each overhaul, or any time the pump overheats and activates the valve. **Never** replace this valve with a substitute which has not been specified or provided by Thomas Pump & Machinery.

Periodically, the valve should be removed for inspection and cleaning. When reinstalling the relief valve, apply 'Loctite Pipe Sealant With Teflon No. 592', or equivalent compound, on the relief valve threads. Position the valve as shown in Figure 1 with the discharge port pointing down.

Final Pump Assembly

(Figure 1)

Install the shaft key (13, Figure 2) and reconnect the power source. Be sure to install any guards used over the rotating members.

DANGER!

Do not operate the pump without the guards in place over the rotating parts. Exposed rotating parts can catch clothing, fingers, or tools, causing severe injury to personnel.

Install the suction and discharge lines and open all valves. Make certain that all piping connections are tight, properly supported and secure.

Be sure the pump and power source have been properly lubricated, see **LUBRICATION**.

Remove the fill cover assembly (13) and fill the pump casing with clean liquid. Reinstall the fill cover and tighten it. Refer to **OPERATION**, Section C, before putting the pump back into service.

LUBRICATION

Seal Assembly

(Figure 2)

Before starting the pump, remove the vented plug (07) and fill the seal cavity with approximately 20 ounces (0,7 liters) of SAE No. 30 non-detergent oil, or to a level just below the tapped vented plug hole. Clean and reinstall the vented plug. Maintain the oil at this level.

Bearings

(Figure 2)

The bearing housing was fully lubricated when shipped from the factory. Check the oil level regularly through the sight gauge (26). When lubrication is required, add SAE No. 30 non-detergent-oil through the hole for the air vent (08). Do not over-lubricate. Over-lubrication can cause the bearings to overheat, resulting in premature bearing failure.

NOTE

The white reflector in the sight gauge must be positioned horizontally to provide proper drainage.

Under normal conditions, drain the bearing housing once each year and refill with approximately 32 ounces (1liter) clean oil. Change the oil more frequently if the pump is operated continuously or installed in an environment with rapid temperature change.

CAUTION!

Monitor the condition of the bearing lubricant regularly for evidence of rust or moisture condensation. This is especially important in areas where variable and cold temperatures are common.

For cold weather operation, consult the factory or a lubricant supplier for the recommended grade of oil.

Power Source

Consult the literature supplied with the power source, or contact your local power source representative.

WARRANTY

Pumping units manufactured by Thomas Pump & Machinery, are guaranteed to be free from defects in material and workmanship for one year from date of shipment from factory. The obligation under this Warranty, statutory or otherwise, is limited to replacement or repair at factory or at a point designated by TPM, of such as part as shall appear to us upon inspection at such point, to have been defective in material or workmanship.

This Warranty does not obligate Thomas Pump & Machinery to bear the cost of labor or transportation charges in connection with replacement or repair of defective parts; nor shall it apply to a pump upon which repairs or alterations have been made unless authorized by Thomas Pump & Machinery.

No warranty is made in respect to engines, motors or trade accessories, such being subject to warranties of their respective manufactures.

In Submersible Pumps, pump and motor are integral and Submersibles are warranted as a unit. Since motor is subject to an important degree upon quality and performance of electrical controls, unit warranty is valid only when controls have been specified and provided by Thomas Pump & Machinery.

No express implied or statutory warranty, other here set forth is made or authorized to be made by Thomas Pump.

In no event shall Thomas Pump & Machinery be liable for consequential damages or contingent liabilities arising of the failure of Gator Prime pump or parts there of to operate properly.



THOMAS PUMP & MACHINERY, INC ~ SLIDELL, LA 70460, USA