

HEAVY DUTY BALL VALVE PUMPS

For Fluids Containing Settling, Suspended & Floating Solids

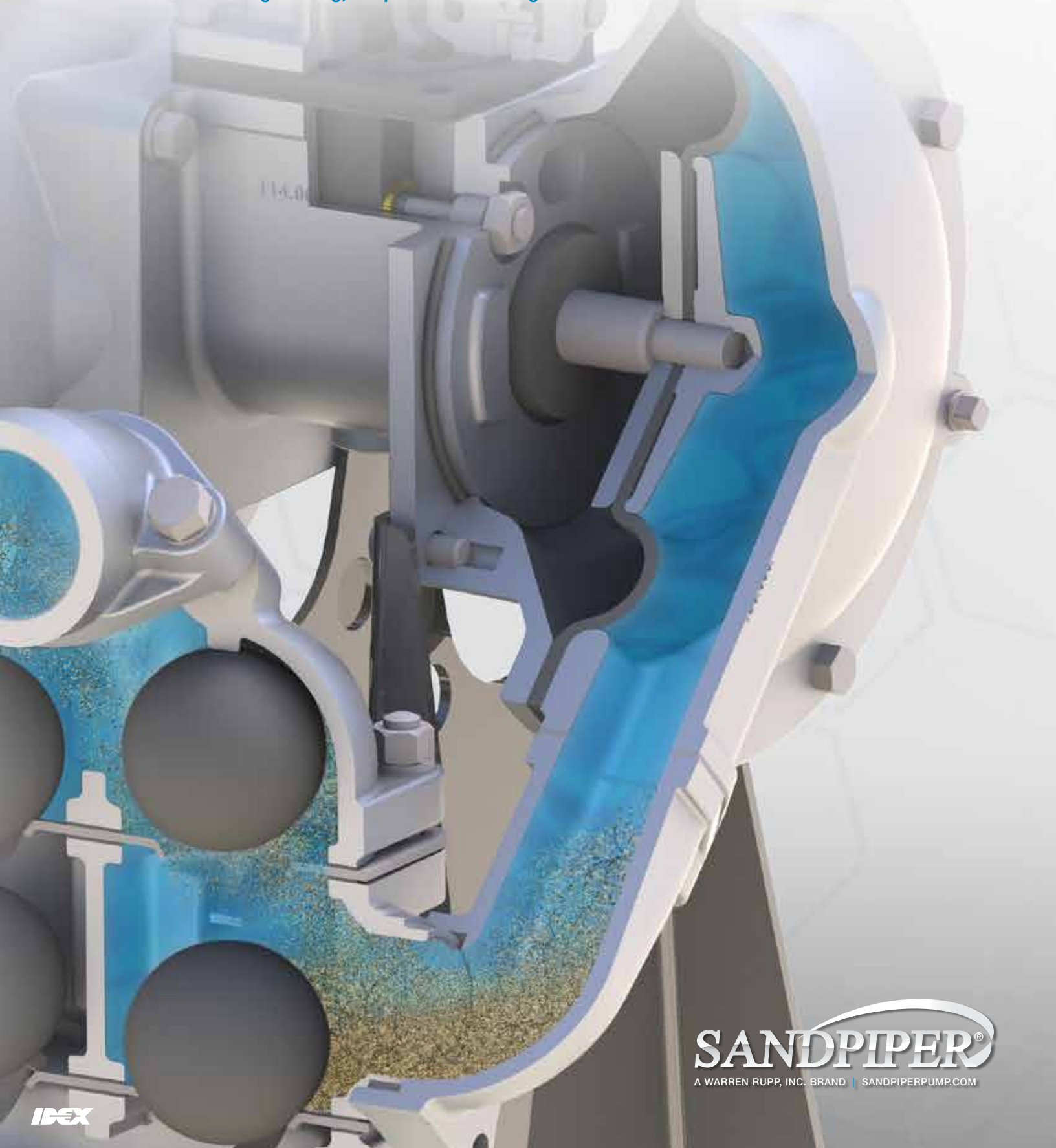

OUR SIGNATURE
ENSURES YOUR SUCCESS



SANDPIPER[®]
A WARREN RUPP, INC. BRAND | SANDPIPERPUMP.COM

IBEX

See back page for Down Ported Advantages

KEY ADVANTAGES OF SANDPIPER HEAVY DUTY BALL VALVE PUMPS

THE SOLUTION FOR FLUIDS CONTAINING SETTLING, SUSPENDED & FLOATING SOLIDS

MULTIPLE PORTING POSITIONS A SANDPIPER EXCLUSIVE

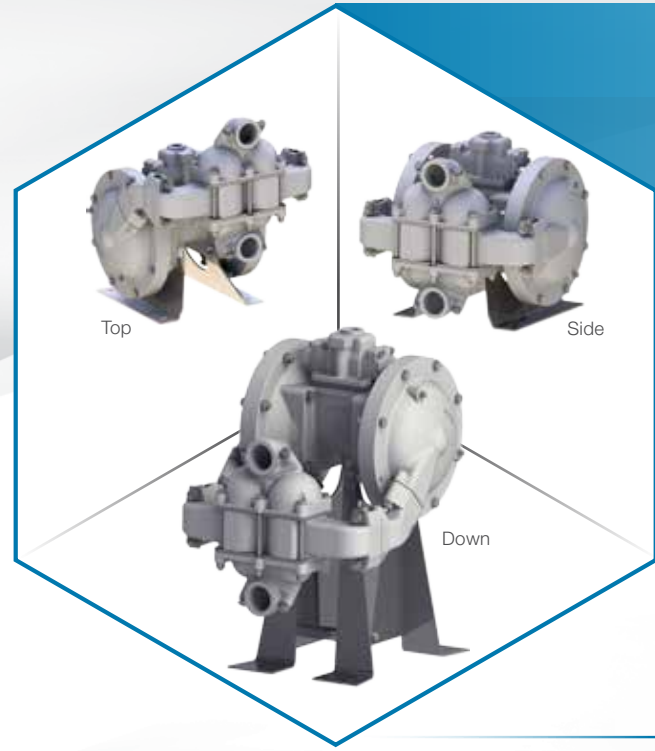

Top, Down, & Side Porting Positions

Optimized performance depending on the pumped fluid or installation requirements.

- **Top Ported:** For fluids containing floating solids, suspended solids, or entrained gases. The discharge port is positioned above the center of the pump for easier evacuation and less build-up of solid material or gases.
- **Down Ported:** For fluids containing settling solids. The discharge port is positioned below the center of the pump so solids settle in the elbow and are discharged. This helps reduce wear on the diaphragms and associated components.
- **Side Ported:** For use in confined spaces. The ports are positioned with the center of the pump, allowing for installation in smaller, confined spaces.



HEAVY DUTY WEAR PARTS A SANDPIPER EXCLUSIVE

SANDPIPER Heavy Duty Ball Valve Pump Features

- Heavy duty plunger bushings and actuator pins are designed to withstand severe applications
- Diaphragm wear pads are installed between the diaphragm and outer diaphragm plate, providing a secondary wear surface which extends the life of the diaphragm
- Thicker, more robust wetted castings provide extended wear resistance
- Heavy duty weighted check valve balls are 30-60% heavier than solid rubber check balls, allowing for more consistent chamber filling

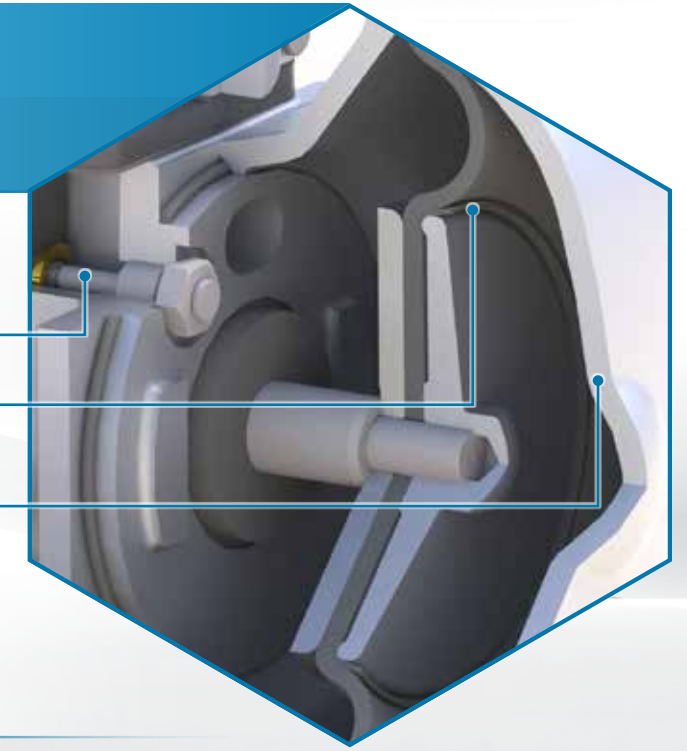

SANDPIPER'S EXTERNALLY SERVICEABLE AIR DISTRIBUTION SYSTEM (ESADS+PLUS) QUICK & EASY ACCESS TO MAXIMIZE UPTIME



The Air Motor's Pilot Valve is the Most Often Serviced Part on an AODD Pump

SANDPIPER's Externally Serviceable Air Distribution System (ESADS+PLUS) allows for quick and easy access to the pilot and spool valves without removing the pump from service, maximizing uptime!

SANDPIPER

5 MINUTES - MAINTENANCE / CLEANING
Accomplished in minutes without removing pump from service by removing only 4 bolts

\$ Saves you money by minimizing downtime

Competitor pumps require disassembly and re-assembly of many parts, requiring additional knowledge and time; leading to increased downtime and cost.

COMPETITORS

55+ MINUTES MAINTENANCE / CLEANING
The air valve components can only be accessed by removing the pump from service and taking it entirely apart

\$\$\$ Costs you money due to extended downtime



FEATURES & BENEFITS

EXCLUSIVE TO SANDPIPER HEAVY DUTY BALL VALVE PUMPS



Externally Serviceable Air Distribution System

Allows for quick and easy access to the main air drive components without disassembly of the entire pump and / or removing it from service



Cross-Drilled Directional Spool Valve

Guarantees the pump will not stall and ensures on / off reliability



All Bolted Construction

Ensure sealing forces are applied evenly across the pump for leak-free operation



Heavy Duty Actuator Plungers

Ensure reliable pilot valve operation



Robust Diaphragm Connecting Rod

Guaranteed not to bend or break; assures reliable and consistent diaphragm operation



Diaphragm Wear Pads

Reduce fluid velocity and frictional losses, which lessens wear and allows for more flow capacity



Weighted Elastomeric Check Balls

For reliable pump performance with viscous fluids



Large Flow Area

Reduces fluid velocity through pump, which often lessens wear



Thick Manifold & Chamber Walls

Greater wear resistance when pumping solids and solid laden slurries, providing extended service life



Top Porting Position



Down Porting Position



Side Porting Position

Only available in certain models

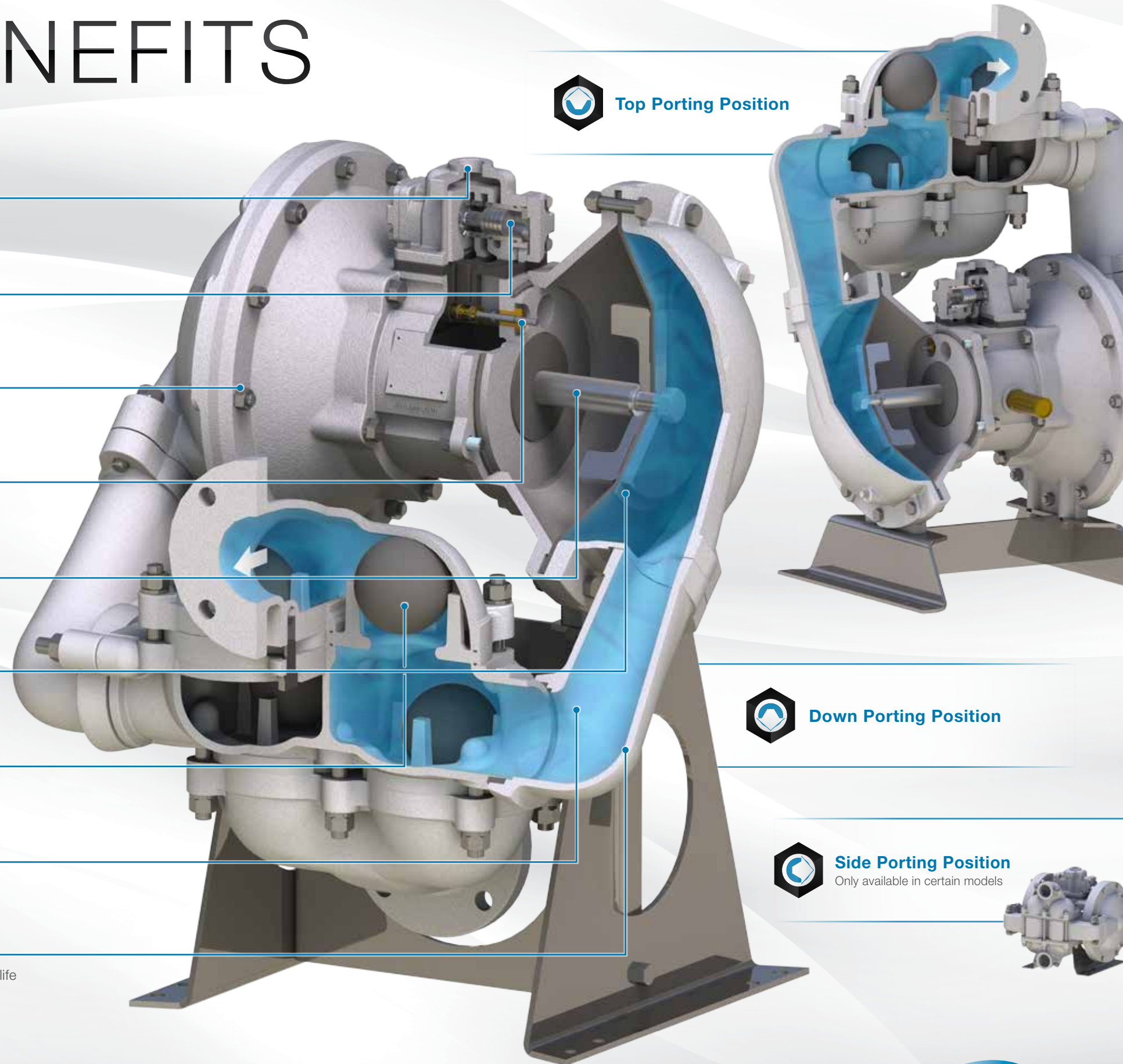

HEAVY DUTY BALL VALVE PUMPS

PERFORMANCE & SPECIFICATIONS

SPECIFICATIONS

SIZES

1 - 4"
25 - 102 mm

FLOW

42 - 260 GPM
159 - 984 LPM

SOLIDS HANDLING

.25 - .875"
6.3 - 22.2 mm

DISPLACEMENT

.09 - 1.8 gallon
.34 - 6.8 liter

COMPOSITE PERFORMANCE CURVE

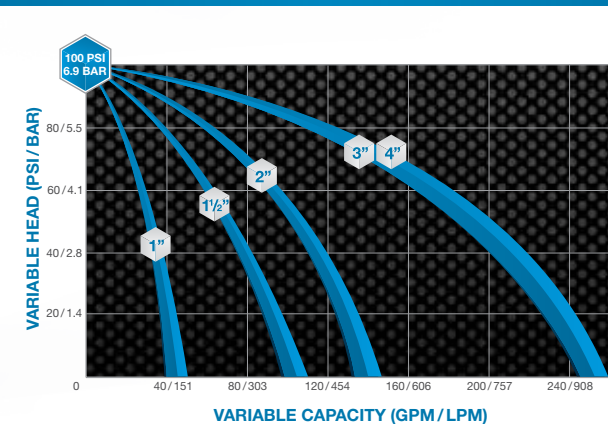

PUMP CHARACTERISTICS

		Metallic	
Fluid Characteristics	Water	✓	
	Suspended Solids	✓	
	Non-Suspended Solids	✓	
	Line Size Solids	⚠ Use Flap Valve Pump	
	Sludge / Slurry	✓	
	High Viscosity (Flowable Fluids)	✓	
	Erosion / Abrasive Fluids	High	✓
		Moderate	✓
		Low	✓
	Corrosion	✓	
Installation	Permanent	✓	
	Portable	✓	
	Containment / Prevention	!	
	Flooded Suction	✓	
	Suction Lift	✓	
	Submerged	✓	
	Duty	Intermittent / On-Demand	✓
Continuous		✓	

✓ = Best ✓ = Suited ! = Limitations ⚠ = Use listed pump

1 1/2"
40 mm

HDB1 1/2 / HDB40 Metallic - Porting: Top, Side, Down



SOLIDS HANDLING
Up to .25" (6.3 mm)

MAX FLOW
105 GPM (397 LPM)

MAX PRESSURE
125 psi (8.6 bar)

DISPLACEMENT
.37 gallon (1.4 liter)

OPTIONS

Porting	Wet End	Elastomers		Air End
1 1/2" NPT / BSP Threaded	Aluminum	Nitrile (Buna)	Fluorocarbon (FKM)	Aluminum
	Stainless Steel	Neoprene	Hytrel®	Cast Iron
	Cast Iron	Santoprene®	EPDM	
	Alloy C	PTFE		

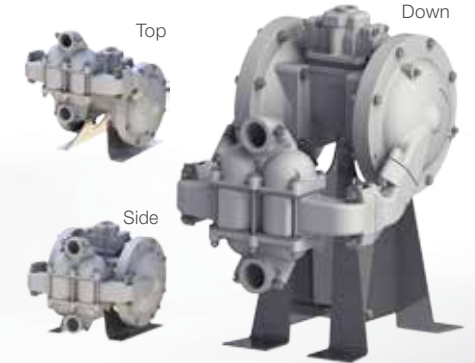

2"
50 mm

HDB2 Metallic - Porting: Top, Down



SOLIDS HANDLING
Up to .375" (9 mm)

MAX FLOW
135 GPM (511 LPM)

MAX PRESSURE
125 psi (8.6 bar)

DISPLACEMENT
.43 gallon (1.63 liter)

OPTIONS

Porting	Wet End	Elastomers		Air End
2" NPT	Aluminum	Nitrile (Buna)	Fluorocarbon (FKM)	Aluminum
	Stainless Steel	Neoprene	Hytrel®	Cast Iron
	Cast Iron	Santoprene®	EPDM	
	Alloy C	PTFE		



Side porting not available for this model

For more detailed Performance and Specification information, please visit SANDPIPERPUMP.COM

1"
25 mm

SB1 / SB25 Metallic - Porting: Top, Side, Down



SOLIDS HANDLING
Up to .25" (6.3 mm)

MAX FLOW
42 GPM (159 LPM)

MAX PRESSURE
125 psi (8.6 bar)

DISPLACEMENT
.09 gallon (.34 liter)

OPTIONS

Porting	Wet End	Elastomers		Air End
1" NPT / BSP Threaded	Aluminum	Nitrile (Buna)	Fluorocarbon (FKM)	Aluminum
	Stainless Steel	Neoprene	Hytrel®	Cast Iron
	Alloy C	Santoprene®	EPDM	
		PTFE		

Santoprene® is a registered trademark of Exxon Mobil Corp. Hytrel® is a registered trademark of E.I. du Pont de Nemours and Company.

3-4"
75-102mm

HDB3 / HDB4 Metallic - Porting: Top, Down



SOLIDS HANDLING
Up to .875" (22.2 mm)

MAX FLOW
260 GPM (984 LPM)

MAX PRESSURE
125 psi (8.6 bar)

DISPLACEMENT
1.8 gallon (6.8 liter)

OPTIONS

Porting	Wet End	Elastomers		Air End
3" ANSI Flange	Stainless Steel	Nitrile (Buna)	Fluorocarbon (FKM)	Cast Iron
	Cast Iron	Neoprene	PTFE	
4" ANSI Flange		Santoprene®		
		EPDM		



Side porting not available for this model

SANDPIPER'S EXCLUSIVE DOWN PORTED ADVANTAGE

SANDPIPER HEAVY DUTY BALL VALVE PUMP

VS

TYPICAL TOP DISCHARGE BALL VALVE PUMP

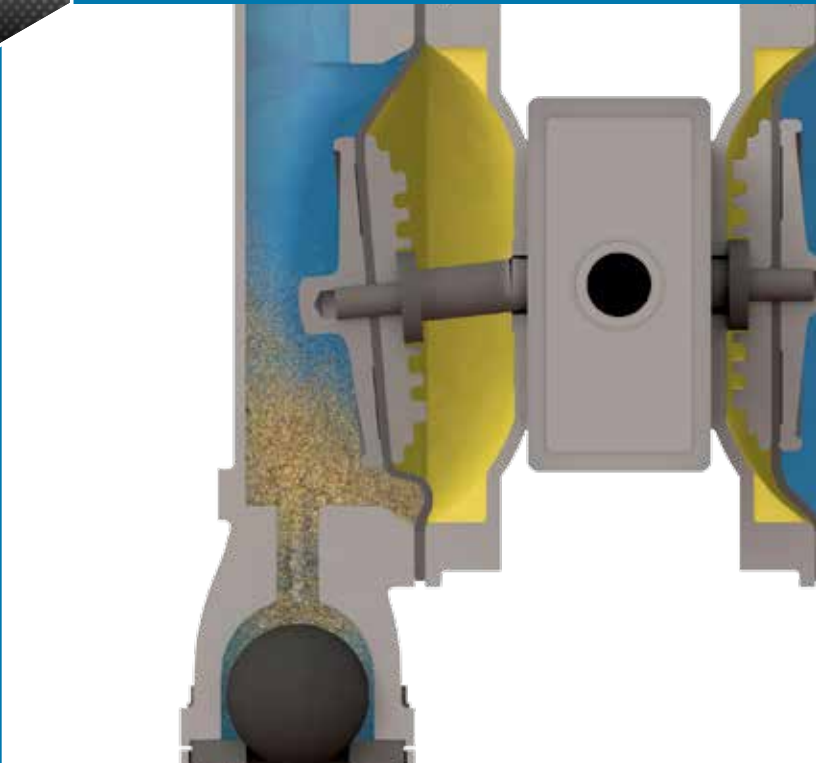

What happens when solids settle in the pump?

- ✓ Nothing impedes the operation of the pump
- ✓ As solids settle, they collect in the elbow instead of the diaphragm chamber and are discharged; this limits wear on the diaphragm and associated components

What happens when solids settle in the pump?

- ✗ Bent, broken diaphragm plates
- ✗ Non-uniform diaphragm wear
- ✗ Bent, broken diaphragm connecting rods
- ✗ Restriction on the suction side of the pump

SANDPIPER[®]

Warren Rupp, Inc. | A Unit of IDEX Corporation
800 North Main Street, Mansfield, OH 44902 USA
Phone: 419.524.8388 | Fax: 419.522.7867
SANDPIPERPUMP.COM



Contact Your Local Distributor to Place Your Order:

IDEX