



CHEMPUMP
A DIVISION OF TEIKOKU USA INC.

Instruction Manual

for: Installation, Operation, & Maintenance

CHEMPUMP

Sealless Leakproof Canned Motor Pump

NC SERIES

Table of Contents

Paragraph	Page
SECTION 1. GENERAL INFORMATION	
1-1. General Design and Operation	1-1
1-2. Stator Assembly	1-3
1-3. Rotor Assembly	1-3
1-4. Bearings	1-3
1-5. Thrust Washers	1-3
1-6. Cooling Flow	1-3
1-7. Automatic Thrust Balance	1-3
SECTION 2. INSTALLATION	
2-1. Receipt Inspection	2-1
2-1.1. Storage Note	2-1
2-2. Structural	2-1
2-2.1. Pump Location	2-1
2-2.2. Mounting and Alignment	2-1
2-2.3. Piping Data	2-2
2-3. Electrical	2-3
2-3.1. General	2-3
2-3.2. Thermal Cut-Out	2-3
2-3.3. Starting Equipment	2-3
2-3.4. Oil Filled Stator	2-5
2-3.5. Direction of Rotation Indicator	2-5
2-3.6. IntelliSense Diagnostics System	2-5
2-4. Special Conditions and Features	2-6
2-4.1. Backflushing	2-6
2-4.2. Reverse Circulation	2-6
2-4.3. Electrical Isolation	2-7
2-4.4. Water and Steam Jackets	2-7
2-4.5. Heat Exchanger	2-7
2-4.6. Internal Circulation	2-7
SECTION 3. OPERATION	
3-1. Procedure Before Initial Start-up	3-1
3-2. Priming and Venting	3-1
3-3. Rotation Check	3-1
3-4. Starting Procedure	3-1
3-5. Operation Details	3-2
3-6. Shutdown Procedure	3-2

SECTION 4. MAINTENANCE

4-1. Periodic Inspection	4-1
4-1.1. Recommended Tools For Disassembly and Reassembly	4-1
4-1.2. Recommended Tools For Inspection	4-1
4-2. Disassembly	4-1
4-3. Inspection	4-2
4-3.1. Bearing Inspection	4-2
4-3.2. Automatic Thrust Balance and End Play Inspection	4-3
4-3.3. Rotor Assembly Inspection	4-3
4-3.4. Stator Assembly Inspection	4-3
4-3.5. General Inspection	4-3
4-4. Reassembly	4-3
4-5. IntelliSense Calibration Procedure	4-4
4-6. Lubrication	4-4
4-7. Cooling	4-4
4-8. Service Policy	4-5
4-9. Spare Parts	4-5

APPENDIX

Sample: Trouble Analysis Sheet	A-1
Fluid Decontamination (Page 1 of 2)	A-2
Fluid Decontamination (Page 2 of 2)	A-3
<u>Performance Curves</u>	
Model NC-AA-6	A-4
Model NC-AB-6	A-5
Model NC-AA-8	A-6
Model NC-A50-8	A-7
Model NC-A60-8	A-8
Model NC-A05-10	A-9
Model NC-A50-10	A-10
Model NC-A60-10	A-11
<u>Outline Drawings</u>	
Models NC-AA & NC-AB	A-12
Models NC-A05, NC-A50 & NC-A60	A-13
<u>Cross Section Drawing (all models)</u>	A-14
<u>Figures</u>	
1-1 NC Series Standard Circulation	1-1
1-2 Discharge Filter Arrangement	1-1
1-3 NC Series Chempumps	1-2
1-4 NC Series sleeve type bearing	1-3
1-5 Automatic Thrust Balance	1-3
2-1 Easy Maintenance Base	2-2
2-2 Wiring Diagram 460 Volt, 3 Phase	2-4
2-3 Wiring Diagram voltages other than 460	2-4
2-4 Typical Backflush System	2-6
2-5 Reverse Circulation System	2-6

Tables

2-1 NC Series Electrical Data	2-5
2-2 Recirculation Flow Rate	2-6
2-3 Electrical Wiring Data, 230 Volt	2-8
2-4 Electrical Wiring Data, 460 Volt	2-8
2-5 Electrical Wiring Data, 575 Volt	2-8
4-1 NC Series Bearing and Journal dimensions	4-3
4-2 Coil Resistance Values	4-6
4-3 Trouble Shooting	4-7

SECTION 1. GENERAL INFORMATION

1-1. General Design and Operation

The NC Series is a combined centrifugal pump and squirrel cage induction electric motor built together into a single hermetically sealed unit. The pump impeller is of the closed type, and is mounted on one end of the rotor shaft which extends from the motor section into the pump casing. The rotor is submerged in the fluid being pumped and is, therefore, "canned" to isolate the motor parts from contact with the fluid. The stator winding is also "canned" to isolate it from the fluid being pumped. Bearings are submerged in system fluid and are, therefore, continually lubricated.

The Chempump has only one moving part, a combined rotor-impeller assembly which is driven by the magnetic field of an induction motor. A portion of the pumped fluid is allowed to recirculate through the rotor cavity to cool the motor and lubricate the bearings. The stator windings are protected from contact with the recirculating fluid by a corrosion resistant, non-magnetic, alloy liner which completely seals or "cans" the stator winding. The recirculating fluid passes through a self-cleaning cylindrical filter (fitted in the discharge nozzle of the pump casing), through the circulation tube, to the motor adapter, entering the motor section at the front bearing. A portion of the pumpage flows across the front bearing and returns to the rear of the impeller. The remainder passes over the rotor, across the rear bearing, and returns to suction through a hollow shaft. See Figure 1-1.

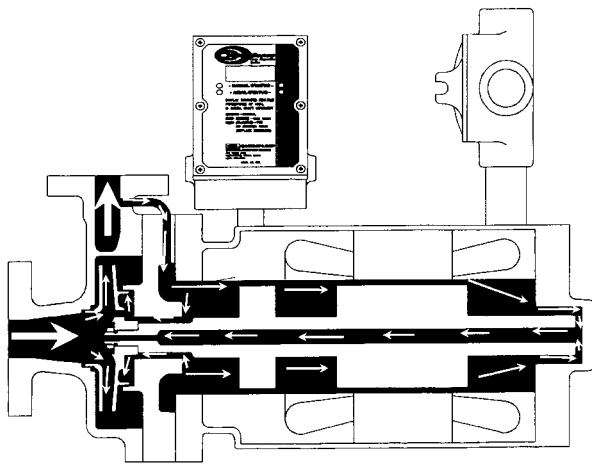

**Figure 1-1: NC Series Chempump
Standard Circulation**

The discharge filter, Figure 1-2, located in the discharge nozzle of the pump casing helps to extend motor and bearing life by keeping the circulating fluid free of damaging particles. This filter is open top and bottom and is constantly washed by the discharge flow. Certain types of solids are gummy and will adhere to the fine wire mesh, thus restricting flow to the bearings. An indication of restricted flow will be increased temperature in the motor section and subsequent higher temperature of the motor housing. If this occurs, an inspection of the filter should be made to determine cause of restricted flow.

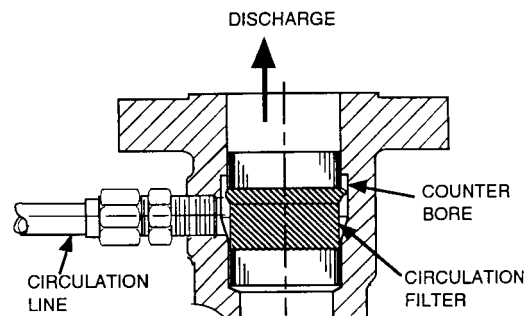

Figure 1-2: Discharge Filter Arrangement

The Chempump sealless pump is a precision-built unit that, with proper care, will give years of trouble-free, leakproof service. This manual, containing basic instructions for installation, operation and maintenance of Chempumps, is designed to assist you in obtaining this service.

It is important that the persons responsible for the installation, operation, and maintenance of the pump, read and understand the manual thoroughly. Trouble-free Chempump performance begins with proper pump selection and application. If the selected pump does not have the required performance characteristics, or if the materials of construction are not properly specified for the fluid being handled, unsatisfactory operation may result. No amount of maintenance can compensate for this.

If you are in doubt on Chempump selection or application, write or call your Chempump engineering representative or the factory for assistance and advice. Additional copies of this manual are available from the Chempump field representative or from the factory.

The entire unit is mounted on a fabricated steel base plate. Operation is unaffected by the mounting or operating position, eliminating the need for any costly alignment procedures. See Figure 1-3, Page 1-2.

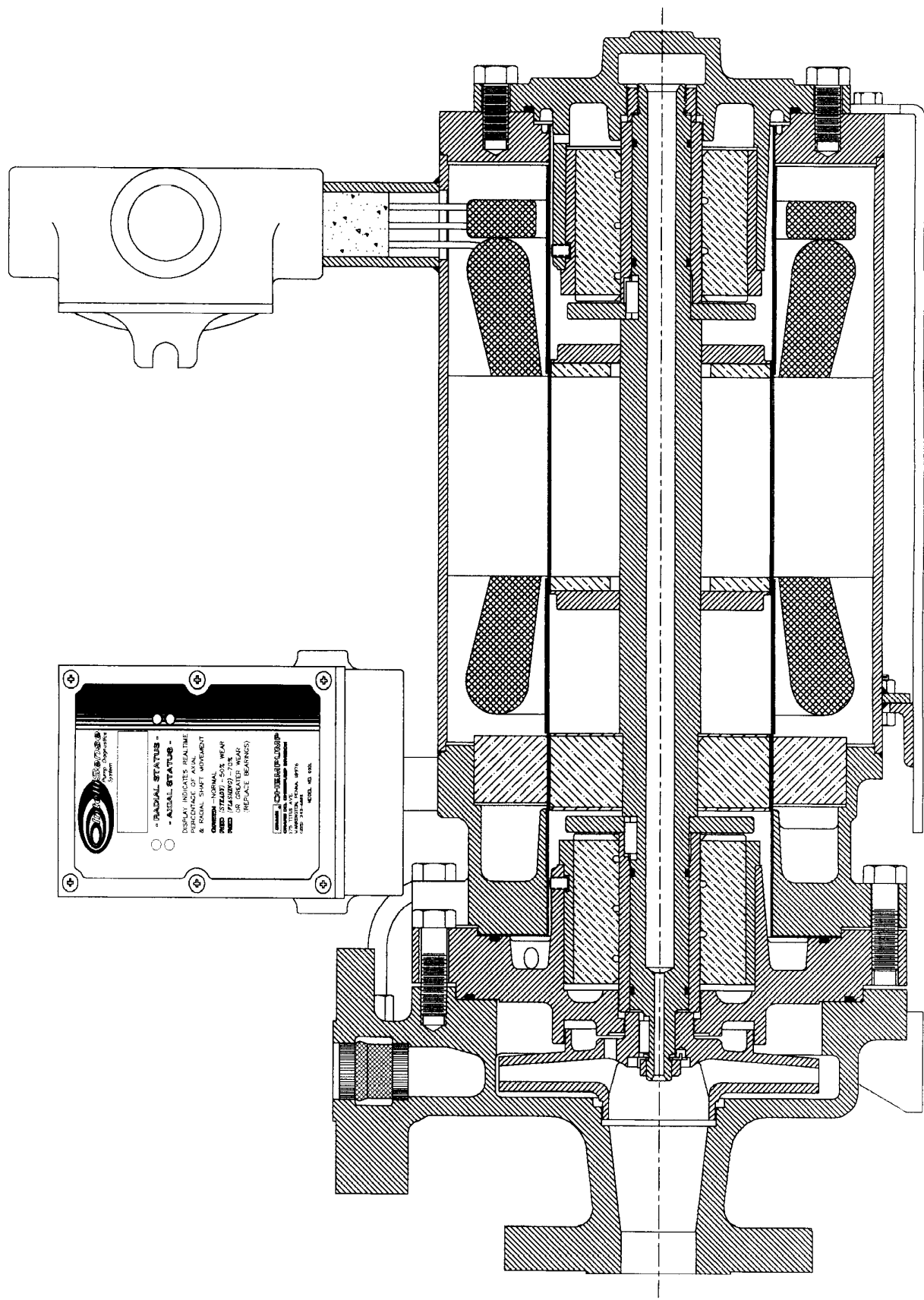

Figure 1-3: NC Series Chempumps

1-2. Stator Assembly

The stator assembly consists of a set of three-phase windings connected in a one circuit wye arrangement. Stator laminations are of low-silicon grade steel. Laminations and windings are mounted inside the cylindrical stator band. End bells, welded to the stator band, close off the ends of the stator assembly. Back up sleeves are provided to strengthen those areas of the stator liner not supported by the stator laminations. The stator liner is, in effect, a cylindrical "can" placed in the stator bore and welded to the rear end bell and front end bell shroud to hermetically seal off the windings from contact with the liquid being pumped. Terminal leads from the windings are brought out through a pressure tight lead connector mounted on the stator band and terminated in a standard connection box.

1-3. Rotor Assembly

The rotor assembly is a squirrel cage induction rotor constructed and machined for use in the Chempump. It consists of a machined corrosion resistant hollow shaft, laminated core with copper bars and end rings, corrosion resistant end covers, and a corrosion resistant can. The shaft is provided with an impeller key arrangement at one end to receive the impeller and is threaded at the same end to receive the impeller nut which retains the impeller.

The rotor end covers are welded to the shaft and also to the rotor can which surrounds the outside of the rotor, thus hermetically sealing off the rotor core from contact with the liquid being pumped.

The shaft is fitted with replaceable shaft sleeves and thrust surfaces. These parts are keyed to prevent turning. Axial movement is restricted by the impeller hub in the front and by a retaining nut in the rear.

1-4. Bearings

The bearings for the NC Series are metal sleeved carbon/graphite as standard (other materials are furnished depending on the application) and are machined with a special helix groove through the bore to assure adequate fluid circulation at the journal area. Each bearing is manufactured to close tolerances for a high degree of concentricity and is held in a bearing housing by a retaining screw. Bearings are easily replaced by removing the retaining screw and sliding the bearing from its housing. See Figure 1-4.

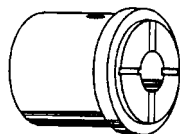

Figure 1-4: NC Series Sleeved Type Bearing

1-5. Thrust Washers

All NC Series Chempump models are equipped with thrust surfaces providing a replaceable bearing surface against which axial loads can be carried during upset conditions. The shaft is fitted with replaceable shaft sleeves and thrust surfaces. These parts are keyed to prevent turning. Axial movement is restricted by the impeller hub in the front and by a retaining nut in the rear. These surfaces prevent metal to metal contact at the impeller and pump casing in the event of abnormal pump operation such as running dry or cavitation.

1-6. Cooling Flow

Cooling for stator, rotor, and bearings, as well as bearing lubrication, is provided by circulation of the pumped fluid. A portion of the fluid circulates through the circulation tube to the motor adapter, entering the motor section at the front bearing. A portion of the fluid flows across the front bearing and returns to the rear of the impeller. The remainder passes over the rotor, across the rear bearing, and returns to suction through the hollow shaft. See Figure 1-1, Page 1-1.

1-7. Automatic Thrust Balance

Based on hydraulic principles, Chempump's automatic thrust balance is accomplished by the pressure of the pumped fluid itself, operating in a balance chamber on the front and rear of the impeller.

When a change in load tends to change the position of the impeller away from the balance condition, there is an equalizing change of hydraulic pressure in the balance chambers which immediately returns the impeller-rotor assembly to the balanced position. See Figure 1-5.

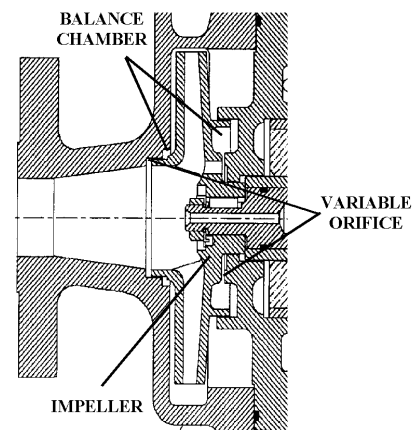

Figure 1-5: Automatic Thrust Balance

SECTION 2. INSTALLATION

2-1. Receipt Inspection

1. Visually inspect the shipping container for evidence of damage during shipment.
2. Check unit to see that suction and discharge and any other connections are sealed.
3. Inspect the suction and discharge gasket seating surface to be certain that they are clean of foreign matter and free from nicks, gouges and scratches.
4. Visually inspect the unit for evidence of shipping damage:
 - a. Circulation line bent or compressed
 - b. Flange faces
 - c. Junction boxes and nipples on stator assembly bent or compressed
 - d. Vent and drain plugs properly installed
5. Megger resistance to ground of the motor windings. Refer to Table 4-2, Page 4-6. **DO NOT SURGE TEST OR HI POT MOTOR WINDINGS.**
6. Check all nameplate data against shipping papers.
7. Caution should be observed during handling so as not to bend the circulation line.

2-1.1. Storage Note

In situations where a Chempump is to be stored for a period of time prior to installation and where the climate experiences wide temperature changes and high humidity, the terminal box, suction and discharge flange, and any other openings must be sealed to prevent moisture from entering the internals of the pump.

2-2. Structural

The pump design and construction eliminates the necessity of aligning the pump and motor. The pump should be supported from the mountings provided. It should be mounted in such a way as to have its weight properly supported. Suction and discharge piping must be properly supported and aligned so that no strain is placed on the pump casing.

General

1. Remove burrs and sharp edges from flanges when making up joints.
2. When connecting flanged joints, be sure inside diameters match within 1/16" diametrically so as not to impose a strain on the pump casing.
3. Use pipe hangers or supports at intervals as necessary.

2-2.1. Pump Location

Locate the pump as close as possible to the fluid supply with a positive suction head. Installations with suction lift are possible but not recommended.

Since standard pumps are not self-priming, provide for initial priming and for maintaining a primed condition. Location of the pump and arrangement of the system should be such that sufficient NPSH (Net Positive Suction Head) is provided over vapor pressure of the fluid at the pump inlet. NPSH requirements at the design point are stated on the pump order data sheet. For additional design points, refer to the corresponding performance curves located in the Appendix of this manual.

NOTE:

Experience has proved that most pump troubles result from poor suction condition including insufficient NPSH. The suction line must have as few pressure drops as possible and available NPSH **MUST** be greater than required NPSH.

Depending on job conditions, available NPSH can sometimes be increased to suit that required by the pump for satisfactory operation. NPSH can be "tailored" by changes in the piping, in liquid supply level, by pressurizing the suction vessel and by several other methods. Refer to Table 4-3, Page 4-7, Trouble Shooting.

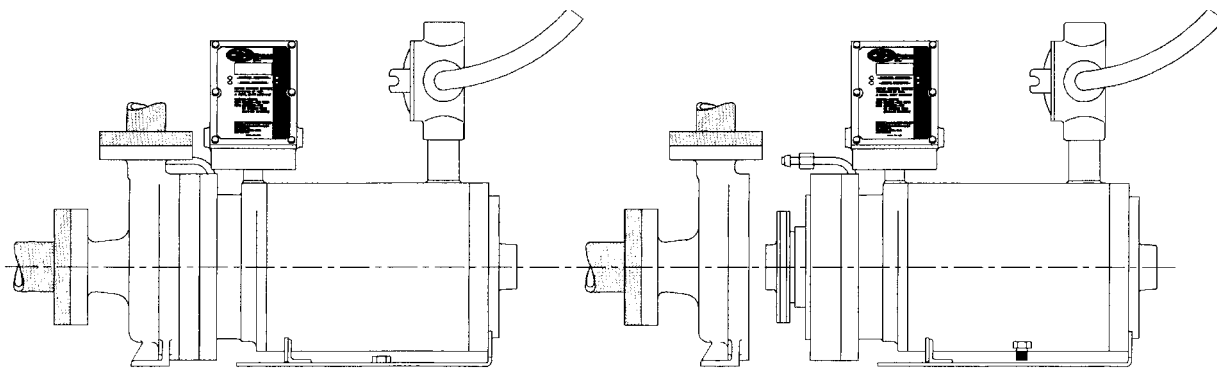

Figure 2-1. Easy Maintenance Base

2-2.2. Mounting and Alignment

The Chempump combines a pump and motor in a single hermetically sealed unit. No tedious coupling alignment is required because the pump has no external coupling between pump and motor. All models can be mounted in any position.

For mounting with suction and discharge on the side or in any other position, modifications must be made to the standard internal venting arrangement.

Bases are offered on all models. You merely have to set the pumps on a foundation strong enough to support their weight. There is no need to bolt down or grout in a Chempump. All NC Series models are provided with a specially made base designed to mount on a standard ANSI baseplate to facilitate inspection and repair. See Figure 2-1.

Be sure that suction and discharge piping is properly aligned so that no strain is placed on the pump casing by out-of-line piping.

2-2.3. Piping Data

Observe the standards of the Hydraulic Institute when sizing and making up suction and discharge piping. Follow these procedures:

1. Remove burrs and sharp edges when making up joints.
2. When using flanged joints, be sure inside diameters match properly. When gasketing flanged joints, DO NOT cut flow hole smaller than flange opening.
3. Use pipe hangers or supports at necessary intervals.
4. Provide for pipe expansion when required by fluid temperature.

5. When welding joints, avoid possibility of welding shot entering the suction or discharge line, and thereby entering the pump. Do not weld pipe while connected to pump.
6. When starting up a new system, place a temporary 3/16" mesh screen at or near suction port of pump to catch welding shot, scale or other foreign matter. (Refer to Section 3).
7. Do not spring piping when making up any connections.
8. Make suction piping as straight as possible, avoiding unnecessary elbows. Where necessary, use 45 degree or long-sweep 90 degree fittings.
9. Make suction piping short, direct, and never smaller in diameter than suction opening of pump. Suction piping should be equal to or larger than pump suction port, depending on pipe length.
10. Insure that all joints in suction piping are air-tight.
11. When installing valves and other fittings, position them to avoid formation of air pockets.
12. Permanently mounted suction filters are not recommended.

It is extremely important to size and layout the suction system to minimize pressure losses and to be sure that the pump will not be "starved" for fluid during operation. NPSH problems are a result of improper suction systems.

If suction pipe length is short, pipe diameter can be the same size as the pump suction port diameter. If suction piping is long, the size should be one or two sizes larger than pump suction port, depending on piping length. Use the largest pipe size practical on suction piping and keep piping short and free from elbows, tees or other sources of pressure drop. If elbows, tees or valves must be used, locate them from 10 to 15 pipe diameters upstream from suction.

When reducing to pump suction port diameter, use eccentric reducers with eccentric side down to avoid air pockets.

When operating under conditions where pump prime can be lost during off cycles, a foot valve should be provided in the suction line to avoid the necessity of priming each time the pump is started. This valve should be of the flapper type rather than the multiple spring type and of ample size to avoid undue friction loss in the suction line.

When foot valves are used, or when there are other possibilities of fluid hammer, it is important to close the discharge valve before shutting down the pump.

When necessary to connect two or more pumps to the same suction line, provide gate valves so that any pump can be isolated from the line. Install gate valves with stems horizontal to avoid air pockets. Globe valves should be avoided, particularly where NPSH is critical.

If discharge pipe length is normal, pipe diameter can be the same size as the pump discharge port diameter. If discharge piping is of considerable length, use larger diameter pipe (one or two sizes larger).

If the pump is to discharge into a closed system or an elevated tank, place a gate valve or check valve in the discharge line close to the pump. The pump can then be opened for inspection without fluid loss or damage to the immediate area.

RECOMMENDED

Install properly sized pressure gauges in suction and discharge lines near the pump ports so that operation of the pump and system can be easily observed. Should cavitation, vapor binding, or unstable operation occur, widely fluctuating discharge pressures will be observed.

Such gauges provide a positive means of determining actual system conditions and can be used to great advantage in evaluating system problems.

2-3. Electrical

2-3.1. General

Except where indicated, all Chempumps are started with full line voltage. Phase sequence is shown on the name plate. Refer to Paragraph 3-3, Page 3-1, for checking direction of rotation. Also see Wiring Diagram Figures 2-2, or 2-3, Page 2-4 depending on electrical source characteristics.

2-3.2. Thermal Cut-Out

Unless otherwise specified, all Chempumps are fitted with thermal cut-outs. The cut-out is a heat-sensitive bimetallic switch mounted in intimate contact with the stator windings. It is to be wired in series with the holding coil in the starter box by removing a jumper as shown in Figures 2-2 or 2-3, Page 2-4. Maximum holding coil currents is 3.1 AMPS for 115 volts.

WARNING

Do not connect TCO in series with main power lead. Excessive heat build up in the winding area opens the normally closed thermal switch which, in turn, opens the holding coil circuit, shutting off power to the pump. Be sure to connect the thermal cut-out as required.

Thermal cut-outs in Class R insulated motors are set to open at 425°F. Depending on the application, specially set TCO's are sometimes provided. The pump order data sheet indicates the TCO setting. If the motor cuts out because of TCO action, there will be a time delay before the motor can be restarted. The motor must be restarted manually. **DO NOT RESTART UNTIL YOU DETERMINE THE SOURCE OF THE OVER-HEATING.**

WARNING

The thermal cut-out switch does not provide protection against fast heat build-up resulting from locked rotor conditions, single phasing or heavy overloads. This protection must be provided for by the current overload relay heaters in the magnetic starter. The rating of the heaters should be high enough to avoid nuisance cut outs under running loads, but must not be oversized. Refer to Table 2-1, Page 2-5, for starting and running electrical characteristics. It is recommended that "quick trip" (Class 10 heaters) be used because of the more rapid response time.

2-3.3. Starting Equipment

Motor starters (normally not supplied with Chempump) should be sized to handle the load required. Start KVA, Full Load Hp and Full Load Amps Data are listed in Table 2-1, Page 2-5.

Heaters in the starters should be sized for the amperage shown on the Chempump nameplate. DO NOT size heaters in excess of 10% of full load amp rating. In order to provide complete protection for Chempump motors under all conditions, it is recommended that “quick trip” (Class 10) type heaters be used in the starters where available. Standard heaters provide adequate protection for Chempump motors under starting or normal running conditions, but require a greater length of time than “quick trip” type heaters to cut out if the motor is subject to locked rotor or overload conditions. Also see Tables 2-3, 2-4, or 2-5, Page 2-8, for electrical wiring data for the most common Chempump motor sizes to assist in the electrical installation of the unit.

Identification Code	Motor Stator Temperature Limit
T2D	419°F/215°C
T3C	320°F/160°C

CASE I - 460 VOLT, 3-PHASE CHEMPUMP

(See Figure 2-2).

Typical 3-phase across-the-line magnetic starter with start-stop push button station shown.

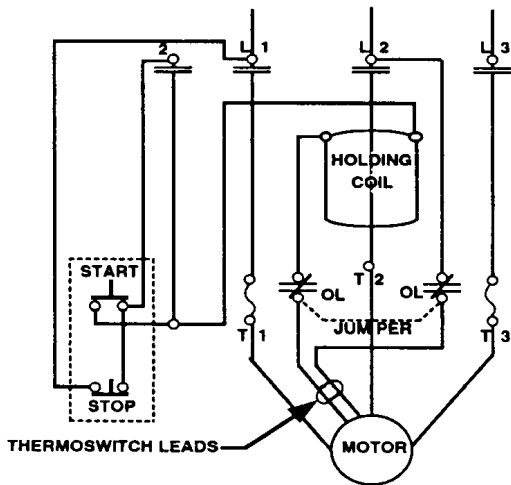

Figure 2-2: Wiring Diagram 460 Volt, 3 Phase

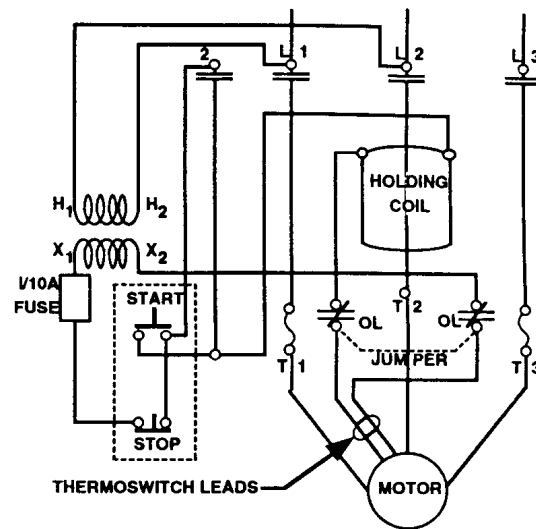

Figure 2-3: Wiring Diagram voltages other than 460 Volt, 3 Phase

Thermoswitch (thermal cut-out inside Chempump motor) is wired in series with holding coil circuit by removing jumper between over load cut-outs as shown.

Be sure to size heaters properly. Rating should be as close as possible to current draw noted on pump nameplate.

CASE II - All other voltages (not to exceed 600 volts), 3-PHASE CHEMPUMP (See Figure 2-3).

Use transformer with primary and 115 volt secondary. Use properly rated holding coil (115 volt). Wire Thermoswitch as for 460 volt systems described in Case 1.

TABLE 2-1. NC Series Electrical Data

MOTOR SIZE	START KVA	FULL LOAD KW	FULL LOAD BHP	FULL AND NO LOAD CURRENTS AT 230 VOLTS F.L./N.L.	FULL AND NO LOAD CURRENTS AT 460 VOLTS F.L./N.L.	FULL AND NO LOAD CURRENTS AT 575 VOLTS F.L./N.L.	MAX PROCESS FLUID TEMP AT FULL LOAD
N1	25.5	7.0	6.8	20.8 / 7.2	10.4 / 3.6	8.3 / 2.9	300
N2	43.8	13.4	13.5	37.2 / 9.8	19.6 / 4.9	15.7 / 3.9	300
N3	89.2	21.7	23.0	63.0 / 16.8	31.5 / 8.4	25.2 / 6.7	280
N4	119.5	30.9	34.0	88.0 / 24.0	44.0 / 12	35.2 / 9.6	260
N5	227.1	48.0	50.8	133.8 / 35	66.9 / 17.5	53.5 / 14.0	290

2-3.4. Oil Filled Stator

The NC Series Chempumps are designed to give long, trouble-free service. In order to facilitate the dissipation of heat from the motor section, the stator cavity on standard NC Series Chempumps can be filled at the factory with a heat conductive dielectric oil. This oil filling allows the heat generated by the motor to be conducted to the outside of the unit, thereby maintaining a lower temperature in the motor section and thereby extending the life of the motor. Solid filled or non oil-filled options are available for any applications where an oil filled stator is not desirable.

2-3.5. Direction of Rotation Indicator

The Chempump is a seal-less, leakproof, canned motor pump that combines the pump and motor into a single unit. Because of this design, no rotating parts are exposed to view. This makes it difficult to determine the direction of rotation of the pump.

The exclusive Chempump Direction of Rotation Indicator, (D.R.I.), indicates if the pump is rotating in the correct direction. The Chempump D.R.I. eliminates the use of phase sequence indicators, discharge gauges and other bothersome methods used by plant engineers to insure proper pump rotation.

The Chempump D.R.I. is the easy, positive way to check on pump rotation. The entire unit is a compact, unobtrusive part of the normal electrical junction box. No additional installation work is required, just wire the pump and the D.R.I. is ready to work. When the direction of rotation is correct, an amber light, located on the unit is lit. If the pump is

energized and the light does not go on, reverse any two motor leads and start the unit again. This will reverse the direction of the rotation and the light will glow. The bulb in the D.R.I. has a rated life of 2-1/2 years.

2-3.6. IntelliSense Diagnostics System

Chempump's **IntelliSense** diagnostic system (patent applied for) is designed to detect any change in the rotor position in either the axial or radial direction. A change in rotor position will cause a change in the sensor output. By comparing this output to the established baseline (or as new data) the condition of the pump internal bearings is indicated and interpreted as bearing wear.

The display of the output is configured to show the percentage of bearing wear which has occurred. Since the maximum allowable displacement has been determined, the inherent accuracy of the IntelliSense diagnostic system gives a greater bearing wear safety margin than other bearing wear indicators, especially those that operate on single point failure.

The **IntelliSense** diagnostic monitor has been designed to accommodate a variety of output options and can be configured to match existing or future plant instrumentation without significant modification.

Following bearing replacement the only calibration required is for radial position. This is accomplished by using the procedure described in Section 4-5., Page 4-4.

Please consult the Chempump factory for questions or service on the IntelliSense monitor. Do not adjust or repair the unit in the field. A factory program has been established for replacement of damaged monitors.

2-4. Special Conditions and Features

2-4.1. Backflushing

For normal clear fluid applications, NC Series Chempumps are cooled and lubricated by the fluid being pumped. For slurry and other “dirty” applications, a system of backflushing is recommended. Backflushing is noted on the order when recommended. See Figure 2-4 for a typical back flush installation.

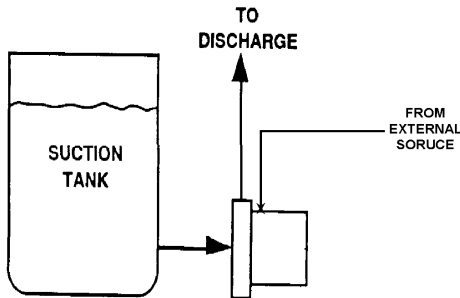

Figure 2-4: Typical Backflush System

Chempumps to be used with back flush are normally supplied without circulating tubes. Clear fluid is brought to the fitting at the front of the motor section by customer’s piping as shown in Figure 2-4. The amount of clear base fluid introduced in this manner should approximate the standard flow rates listed in Table 2-2.

**TABLE 2-2.
RECIRCULATION FLOW RATE**

MODEL	RECIRCULATION FLOW RATE (GPM)	RECIRCULATION FLOW RATE (M3/HR)
NC-AA-6	2.5 - 4.5	0.57 - 1.0
NC-AA-8	3 - 6	0.68 - 1.36
NC-AB-6	3.5 - 4.5	0.79 - 1.0
NC-A50-8	5 - 7	1.14 - 1.59
NC-A60-8	5 - 7	1.14 - 1.59
NC-A05-10	7 - 9	1.59 - 2.04
NC-50-10	7 - 9	1.59 - 2.04
NC-A60-10	8 - 10	1.82 - 2.27

Back flush pressure should be suction pressure plus 20-30% of the pressure developed by the pump. Excessive back flush pressure will destroy the thrust balanced operation built into NC Series Chempumps by causing excessive forward thrust.

Procedure:

1. Remove the circulation tube and plug off the port in the discharge neck of the pump casing. (This is done at the factory if specified in the order).
2. Supply clear liquid to the port in the adapter normally used for the circulating tube size.
3. If the back flushing liquid is hot, auxiliary cooling methods, such as water jacketing the stator must be employed. The temperature of the backflush fluid should not be close to its boiling point and should not exceed 300°F.

2-4.2. Reverse Circulation

For normal clear fluid applications, NC Series Chempumps are cooled and lubricated by the fluid being pumped. However, when the fluid being pumped is at or near its boiling point, the additional heat picked up from the motor combined with the recirculation fluid returning to the low pressure at impeller suction may cause vaporization inside the pump. In these cases the reverse circulation method of lubricating the bearings and cooling the motor should be used. Flow rates should duplicate those shown in Table 2-2.

In reverse circulation the cooling and lubricating fluid is forced from behind the impeller into the motor section. It passes through the front bearing, over the rotor and across the rear bearing. The fluid then exits the rear of the pump and is piped back to the suction vessel (not the suction line).

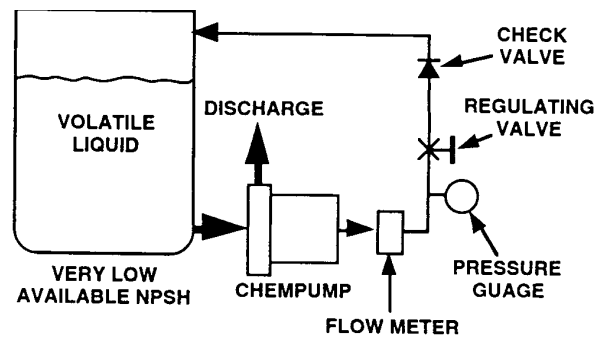

Figure 2-5: Reverse Circulation System

By this method, the fluid in the motor section is maintained at a pressure close to discharge pressure.

Flow through stator-rotor cavity must be controlled to allow for good balance of pressure and temperature without excessive flow. See Figure 2-5, Page 2-6, for a typical reverse circulation installation.

Procedure:

1. Connect tubing (minimum 1/2") to the port provided in the outboard bearing housing.
2. Run the tubing from the connection port fitting in the rear back to the suction receiver, preferably above the liquid level.
3. Use large size suction line and gate valve for low pressure drop and thus improve Available NPSH.

2-4.3 Electrical Isolation

To eliminate electrolytic corrosion when handling solutions during an electrolysis or plating operation, Chempumps should be electrically isolated. Insulated couplings or non-conductive plastic piping must be used in the primary suction and discharge lines. The Chempump must be isolated electrically from the tank, and separately grounded.

2-4.4. Water and Steam Jackets

When handling fluids at controlled temperatures, additional motor cooling or heating must be provided. For temperature control, jackets are provided for water, steam or other heat transfer media. Also, the pump can be submerged into the pumped fluid, thus providing an additional means of temperature control.

All NC Series Chempumps can be provided with removable type water jackets. This type jacket is easily removable from the stator band to allow for inspection and possible replacement. Removable type water jacket kits are available from the factory for Chempumps already installed in the field when additional stator cooling is required. These jackets are

suitable only for heating mediums compatible with the gasket and jacket material, with maximum inlet pressure of 50 psi and with maximum temperature of 150°F. They should not be used as steam jackets. Jackets welded to the stator band are available for use as steam jackets and for liquid mediums which exceed the temperatures and pressures noted above. Normally welded type jackets are suitable for steam pressures to 50 psi and liquid medium pressures to 100 psi. However, welded type jackets, specially fabricated, are also available for higher pressures.

2-4.5. Heat Exchanger

Similar to the water jacket in every respect except for the provision of corrosion resistant tubing, heat exchangers, whether removable, or welded-on, are provided on Chempumps in applications that require heating or cooling the fluid before it enters the rotor chamber. Heat exchangers are especially recommended for liquids with low specific heat characteristics.

All NC Series Chempumps can be provided with removable wrap-around heat exchangers when specified. This type jacket is easily removable from the stator band to allow for inspection and possible replacement. These heat exchangers are suitable for maximum inlet pressure of 50 psi and maximum temperature of 150°F.

Welded on heat exchangers are available on all NC Series Chempumps. These heat exchangers are suitable for steam pressure to 50 psi and liquid medium pressures to 100 psi. Maximum temperatures vary depending upon existing motor insulation and TCO setting as indicated on the pump nameplate

2-4.6. Internal Circulation

Internal Circulation is available on all NC Series pumps. A unit modified for internal circulation requires the elimination of the circulation tube, fittings and discharge filter. Internal flow paths are provided to direct the fluid circulation through the motor and bearings.

NOTE: Please contact the factory prior to any modification to internal circulation.

Table 2-3. Electrical Wiring Data for 230 Volt, 3 Phase, 60 HZ NC Series Chempump

MOTOR SIZE	SWITCH SIZE AMPS	BREAKER SIZE AMPS	STARTER NEMA SIZE	CONDUCTOR SIZE FOR MOTOR LEADS	CONDUIT SIZE FOR MOTOR LEADS ONLY	CONDUIT SIZE FOR MOTOR, PB AND TCO LEADS	FUSE SIZE, CODE AND CURRENT LIMITING AMPS	FUSE SIZE DUAL ELEMENT AMPS	MAX SETTING OF TIME LIMIT PROTECTION
N1	100 (60)	30	1	10	3/4"	1"	55	40	24.0
N2	100 (60)	60	2	8	1"	1"	95	65	42.8
N3	200 (150)	100	4	4	1 1/4"	1 1/4"	165	110	72.5
N4	200 (150)	125	4	2	1 1/2"	1 1/2"	225	155	101.2
N5	400 (200)	200	4	2 / 0	2"	2"	335	235	153.9

Table 2-4. Electrical Wiring Data for 460 Volt, 3 Phase, 60 HZ NC Series Chempump

MOTOR SIZE	SWITCH SIZE AMPS	BREAKER SIZE AMPS	STARTER NEMA SIZE	CONDUCTOR SIZE FOR MOTOR LEADS	CONDUIT SIZE FOR MOTOR LEADS ONLY	CONDUIT SIZE FOR MOTOR, PB AND TCO LEADS	FUSE SIZE, CODE AND CURRENT LIMITING AMPS	FUSE SIZE DUAL ELEMENT AMPS	MAX SETTING OF TIME LIMIT PROTECTION
N1	60 (30)	20	1	12	3/4"	3/4"	30	20	12.0
N2	100 (60)	30	2	10	3/4"	3/4"	50	35	22.6
N3	100 (60)	50	2	8	1"	1"	80	55	36.3
N4	200 (100)	90	3	6	1 1/4"	1 1/4"	110	80	50.6
N5	400 (150)	125	4	4	1 1/2"	1 1/2"	175	120	77.0

Table 2-5. Electrical Wiring Data for 575 Volt, 3 Phase, 60 HZ NC Series Chempump

MOTOR SIZE	SWITCH SIZE AMPS	BREAKER SIZE AMPS	STARTER NEMA SIZE	CONDUCTOR SIZE FOR MOTOR LEADS	CONDUIT SIZE FOR MOTOR LEADS ONLY	CONDUIT SIZE FOR MOTOR, PB AND TCO LEADS	FUSE SIZE, CODE AND CURRENT LIMITING AMPS	FUSE SIZE DUAL ELEMENT AMPS	MAX SETTING OF TIME LIMIT PROTECTION
N1	60 (30)	20	1	12	3/4"	3/4"	20	15	9.6
N2	100 (60)	30	2	10	3/4"	3/4"	40	30	18.0
N3	100 (60)	60	2	8	1"	1"	65	45	29.0
N4	200 (100)	60	3	8	1"	1 1/4"	90	65	40.5
N5	200 (150)	100	4	2	1 1/2"	1 1/2"	135	95	61.6

NOTES:

- 1.) SELECT CLASS 10 HEATERS BASED ON START KVA WITH A 12 SECOND MAX TRIP TIME.
- 2.) () INDICATES REDUCTION IN SWITCH SIZE WHEN DUAL-ELEMENT FUSES ARE USED FOR MOTOR BRANCH CIRCUITS.
- 3.) (EXCEPT WHERE NOTED), THE SWITCH SIZES ARE THE SAME FOR ALL TYPES OF FUSES.
- 4.) CURRENT RATINGS BASED ON THREE CONDUCTOR 75° C INSULATED COPPER WIRE AT 30° C AMBIENT
- 5.) INDUCTION MOTOR, SYNCHRONOUS SPEED 3600 RPM

SECTION 3. OPERATION

3-1. Procedure Before Initial Start-up

Before starting the pump for the first time, make sure suction and discharge piping are free of tools, nuts, bolts, or other foreign matter. Save time and money by checking before start-up.

RECOMMENDED: Install a temporary 3/16" mesh screen near the suction port to trap scale and other foreign particles. The screen can be installed for 24 hours of operation, but watch closely that the pump does not become starved for fluid because of a clogged screen. **REMOVE SCREEN AFTER 24 HOURS OF RUNNING.**

3-2. Priming and Venting

The pump must be primed before operating. Priming requires the filling of the pump casing, rotor chamber and circulation tube with system fluid.

When there is a positive suction head on the pump, priming can be accomplished by opening the valves in the suction and discharge line, and allowing the pump casing, rotor chamber, and circulation tube to fill. The NC Series is centerline discharge and is self-venting.

3-3. Rotation Check

Centrifugal pump impellers must rotate in the proper direction to deliver rated head and capacity. The impeller must rotate in the same direction as the arrow cast in the pump casing. All new Chempumps are supplied with a Direction of Rotation Indicator. Refer to section 2-3.5, Page 2-5, for a complete description of the D.R.I.

If your pump is not equipped with a Direction of Rotation Indicator correct rotation can be checked as follows:

1. Wire Chempump motor for correct voltage.
2. With main power leads connected, check direction of impeller rotation. If the unit is not installed in the system rotation can be observed by "bumping" the motor and looking into the suction flange. **NEVER LOOK INTO THE DISCHARGE FLANGE.** If direction of impeller rotation is incorrect, change two power leads. If the pump is installed and primed, the impeller rotation can be checked by one of two ways:

- a) Use a phase sequence meter on the electrical connections. The readings from the phase sequence meter can be checked against the phase sequence indicated on the Chempump nameplate.
- b) After the Chempump is properly primed and vented, start the unit with the discharge pressure valve almost closed. Note the discharge pressure at a pressure gauge which should be installed between the pump casing and discharge valve. Reverse any two of the three power leads and read the pressure gauge again. The higher pressure is the correct direction of rotation. It is recommended that the unit be run as little as possible with a closed discharge valve in order to prevent excessive overheating of the fluid circulating within the unit.

NOTE

If a discharge valve is not available an alternate method is to use a flow meter and determine higher flow rate. Wrong direction of rotation is indicated by a low discharge pressure or flow rate. At shut-off, head is about 2/3 of the head produced by correct rotation. Continued operation in reverse can result in the impeller's becoming loose or completely detached from the rotor shaft. If reverse rotation has occurred, it is wise to shut down the unit and tighten the impeller nut before restarting.

3. Tag correctly connected main power leads, in accordance with motor lead markings.

3-4. Starting Procedure

After priming and checking the direction of rotation, put the pump in operation as follows:

1. Almost close the valve in the discharge line.
2. Fully open the valve in the suction line.
3. Start the pump.
4. When the pump is running at full speed, slowly open the valve in the discharge line to the desired setting.

CAUTION

The pump should not be allowed to run for more than one minute with the discharge valve fully closed.

NOTES:

1. If the suction and discharge lines are completely filled with system fluid and adequate suction head is available, the pump can be started without closing the discharge valve. During any start up sequence, caution must be exercised not to exceed full load ampere rating indicated on the nameplate.
2. If the unit has not been run for a period of two weeks or more, the following inspections shall precede its operation:
 - a) Check terminal box for moisture.
 - b) Upon starting, check for excessive noise, vibration, erratic speeds or excessive amp draw.

CAUTION

If the pump appears to be air bound as a result of the unit not being properly primed, do not continue operation. Locate and correct the conditions that prevent proper priming before attempting to start the unit.

3-5. Operation Details

Discharge pressure should be checked frequently during operation. Pressure should be stable in a non-variable closed loop although the discharge pressure gauge needle may show small fluctuations.

In some cases, the fluid supply may contain an excessive amount of air or gas which will tend to separate from the fluid and remain in the passage of the pump. This results in the pump losing its prime and becoming air bound with a marked reduction in capacity. The discharge pressure gauge will show large fluctuations if this occurs.

3-6. Shutdown Procedure

Shutdown is as follows:

1. Close the valve in the discharge line.
2. Stop the pump (De-energize the motor).
3. Close suction valves if pump is to be removed from service.

CAUTION

If the pump is to be shut down for a long period of time or if there is danger of freezing, after stopping the pump, shut all suction and discharge valves, and drain the entire pump and connecting piping.

NOTE:

To assist in determining remedies for various problems, see Table 4-3, Page 4-7, Trouble Shooting.

SECTION 4. MAINTENANCE

4-1. Periodic Inspection

Initial inspection of the unit must be made at 1500 running hours or three months, whichever occurs first after initial starting. Subsequent inspection periods will be dependent on the wear rate as indicated in Paragraph 4-3, Page 4-2, but in no case should any inspection period extend beyond three years. Each inspection should include attention to the points noted in each of the following paragraphs.

To assist in determining remedies for pumping or operation problems see Table 4-3, Page 4-7, Troubleshooting.

4-1.1. Recommended Tools for Disassembly and Reassembly

<u>Size (inches)</u>	<u>Description</u>
9/16"	Open end wrench for circulation tube fittings.
3/4" and 15/16"	Open end, box end wrench for pump casing and adaptor bolts.
3/4"	Open end, box end wrench for rear bearing housing bolts and pump casing drain bolts.
1 3/8"	Spanner wrench with 1/8" pin for shaft sleeve retainer.
3/4"	Socket wrench for impeller nut (N1 and N2 motors).
1 1/8"	Socket wrench for impeller nut (N3 and N4 motors).
1 5/16"	Socket wrench for impeller nut (N5 motors).
1/2" and 9/16"	Open end, box end wrench for base cradle bolts.
1/8"	Allen wrench for bearing retainer screws.
Wheel Puller	To assist in the removal of the impeller assembly.

4-1.2. Recommended Tools for Inspection

1. Dial Indicator (.200" travel) for determining end play.

2. Verniers and 5/16" to 3" telescopic gauges for inspection of bearings, I.D. shaft clearance hole, and O.D. of rotor shaft journals.

4-2. Disassembly

1. Close discharge valve, shutdown pump, and then close the suction valve.
2. Disconnect the power cables from the connection box prior to disassembly.
(WARNING: SAFETY HAZARD TO PERSONNEL WILL EXIST IF THIS STEP IS NOT FOLLOWED.)
3. Drain pump and connecting piping.

NOTE: If drains are supplied, the NC Series is designed to drain the majority of fluid in the pump and motor, however a small amount of fluid will still be present. Also, if the pump is equipped with a heat exchanger some of the process fluid may remain in the tubing. Follow your plant safety regulations for flushing and neutralizing the fluid in the pump prior to disconnecting pump from the piping.

4. Begin disassembly, carefully examining each part for corrosion or wear.
5. Remove circulating tube, back flush piping, or reverse circulation piping if so equipped.
6. Remove water jacket cooling inlet and drain connections, if used.
7. Remove bolts holding motor section to pump casing.
8. The base on the NC Series is designed with elongated slots for mounting to a standard ANSI baseplate. Remove the bolts on the base so that the motor section, including the impeller, can be moved backward to clear the pump casing. The complete motor section can be rotated for maintenance in the field or transported to a work area for disassembly. If the base is directly bolted to a concrete pedestal with anchor bolts, this feature is not available and the motor section must be lifted off the anchor bolts for proper maintenance and disassembly.
9. Remove the bolts holding the rear bearing housing to the stator assembly and remove the housing.
10. Remove the screw holding the rear bearing in the rear bearing housing and remove the rear bearing.

11. Remove the impeller nut (Right-hand threads are standard). Then remove the impeller.
12. Withdraw the rotor assembly from rear of motor section taking care not to allow rotor to drop, allowing shaft to hit stator liner.
13. Remove the bolts retaining the motor adapter to the stator assembly, and remove the adapter.
14. Remove the screw holding the front bearing to the front bearing housing, then remove the front bearing.
15. A check for bearing and shaft sleeve wear can be made at this time. Refer to Table 4-1, Page 4-3.
16. If shaft sleeves and/or thrust washer shows scoring or wear, remove them as follows:
 - a. Remove the shaft sleeve retainer in the rear with a spanner wrench (Do not use a pipe wrench). Note: This is a left hand thread.
 - b. Pull the shaft sleeve off the shaft. Sleeves are centered with "o" rings which may present some resistance. If so, pull on the thrust washer which should easily move the sleeve ahead of it.
 - c. Remove key.
 - d. Remove "o" rings from the shaft.
 - e. The front shaft sleeve and the thrust washer are retained by the impeller which has already been removed. Follow steps b. thru d. for the removal of these items.

4-3. Inspection

4-3.1. Bearing Inspection

Since the bearings in this pump are lubricated by the process fluid, it is essential that bearing inspection and replacement periods be based on experience in each particular installation. Bearing life will depend, to some extent, on variable factors including lubrication quality, temperature, number of starts and stops, viscosity, and suspension content of the fluid being pumped, as well as ambient temperature and atmospheric conditions of the operational area. Each time one of these factors is changed, compensation must be applied in bearing inspection periods.

Initial inspection of the bearings should be scheduled at 1500 running hours, or three months, whichever occurs first after initial starting. This inspection is necessary to determine the rate of bearing wear, thereby enabling the setting up of a proper inspection and replacement schedule. See Table 4-1, Page 4-3, for the maximum wear allowable.

If the inspection indicates that bearings are not wearing or are wearing very slightly, the next inspection may be put off for an additional 1500 running hours, or three months of operation, whichever occurs first. If inspection, then, still indicates only slight wear, the interval may be lengthened.

If, however, bearings must be changed at the initial inspection, they will need to be changed again in the time period which necessitated a change at the initial inspection, i.e., 1500 running hours.

Frequency of periodic bearing inspection can best be determined by experience. From these inspections the time for replacement can best be indicated.

Bearings can be inspected and replaced without removing the pump casing from the line. No main piping connections need be broken.

To examine for bearing wear:

1. Measure the inside diameters of the front and rear bearings and compare with the diameter of the rotor shaft sleeve. If the difference in diameters is greater than that indicated in Table 4-1, Page 4-3, replace the bearings.
2. Inspect the thrust faces of the front and rear bearings. If any scoring wear is visualized, measure the length of the bearings. Replace the bearing if the measured length is less than that indicated in Table 4-1.
3. Examine the bearings for any grooving or scoring, particularly on the inside diameter and thrust faces.

Table 4-1 NC Series Bearing and Journal Dimensions

MODEL	UNIT	SHAFT SLEEVE OUTSIDE DIA.	BEARING INSIDE DIA.	diametrical CLEARANCE	MAX. ALLOWABLE	LENGTH
All	Inches	1.6220 - 1.6213	1.626 - 1.627	.004 - .0057	.014	3.0
All	Cm.	6.38	6.4	.02	0.055	11.8

The existence of grooving or scoring indicates the presence of solids or foreign matter in the system which should be eliminated prior to again beginning operation. Grooving or scoring may also occur if the bearings are run without lubrication.

4-3.2. Automatic Thrust Balance and End Play Inspection

The provision of automatic thrust balance design in the NC Series Chempump, with its close running seal faces and wearing rings to insure proper balance chamber pressures, requires that a detailed visual inspection be made of the impeller, front bearing housing, front and rear thrust washer and the pump casing, at the time of bearing inspection.

During disassembly for bearing inspection, measure the unit end play and compare with the following value:

MODEL	MOTOR SIZE	END PLAY (INCHES)
ALL	ALL	0.072 to 0.096 (0.17 to 0.24 Cm.)

If the end play exceeds the maximum allowable movement, then the bearings and/or thrust washers are worn and must be replaced. (It should be noted that under proper operating conditions, wear on these parts due to axial thrust forces will be negligible).

4-3.3. Rotor Assembly Inspection

The complete rotor assembly should be visually inspected for cracks, breaks, pitting, or corrosion which might destroy the effectiveness of the hermetically sealed rotor end covers and sleeve.

The rotor assembly shaft sleeves and thrust surfaces should also be visually inspected at the bearing contact area for general appearance and uniform wear. Excessive undercutting, pitting, or scoring is cause for replacement. Minimum allowable shaft sleeve diameter is noted in Table 4-1.

4-3.4. Stator Assembly Inspection

The complete stator assembly should be visually inspected for cracks, breaks, pitting, or corrosion of the stator liner which may destroy the effectiveness of the barrier. Inspect the wiring by checking the visible portion of the connector leads for cracked, broken or frayed insulation. Check the condition of the motor windings by comparing the ohm meter values with those shown on Table 4-2, Page 4-6.

4-3.5. General Inspection

1. Inspect the impeller nut threads on the rotor shaft to ensure they are not damaged. NC Series Chempumps have right hand threads.
2. Be sure that all mating faces are free of nicks and burrs so that they will have a smooth face ensuring a good seal. Clean off any trace of old gasket material.
3. Make sure all parts are clean. Inaccessible areas may be cleaned with a small brush or pointed tool. The circulation line should be blown out with filtered, oil free, compressed air.
4. The impeller face should be inspected for wear. If excessive grooving or scoring of the wear rings is evident, the impeller must be repaired or replaced.

4-4. Reassembly

1. Reassemble pump by reversing the disassembly procedure. Replace all worn or corroded parts, and “o” rings throughout the pump.
 - a. Before reassembly of the shaft sleeves and thrust washers, clean the shaft of dirt, corrosion products, or residue.
 - b. Put the thrust washer on the shaft.
 - c. Insert key
 - d. Put “o” rings on shaft.
 - e. Slide shaft sleeve on shaft, engaging the key, until it is seated against the thrust washer.
 - f. Replace the retainer in the rear and the impeller in the front.

- Complete reassembly. However, before bolting the motor section to the pump casing, spin the rotor impeller assembly by hand to insure that it does not bind. Also, check end play again as noted in Paragraph 4-3-1, Page 4-2.
- In reassembling the impeller nut, care must be taken to completely tighten the impeller nut and lockwasher against the impeller to insure that it securely holds the impeller against the shaft shoulder.

4-5. IntelliSense Calibration Procedure

Whenever the bearings, shaft sleeves or thrust washers are replaced the following procedure must be followed to recalibrate the IntelliSense diagnostic monitor:

- Energize the pump and run for 5 minutes at the design point.
- Remove the six (6) screws that secure the coverplate to the IntelliSense box and then remove the coverplate, trim ring and gasket.
- Push down switch #5 on Dip switch SW1 located in the lower left corner of the circuit board to the "ON" position.

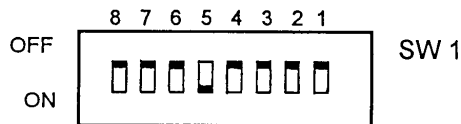

DO NOT TOUCH ANY OTHER SWITCH

- After 1 to 2 seconds the word "CAL" will momentarily appear on the display.

The message "CAL" appears during calibration. Any other message, such as ER02, if it appears for more than an instant indicates a malfunction. In this event please contact the factory as soon as possible.

- After the word "CAL" is replaced with a number, push switch #5 up to the "OFF" position.

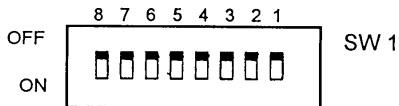

- Replace the gasket, coverplate and trim ring. Secure with the 6 screws.

The IntelliSense monitor is calibrated at the factory. Any tampering with the Dip switch or trim pots, except as noted above, voids the warranty.

4-6. Lubrication

The NC Series Chempump requires no external lubrication. Bearing surfaces and other parts are lubricated by the fluid being pumped.

4-7. Cooling

The motor rear bearing housing temperature is a direct indication of the efficiency of the cooling and lubrication functions of the fluid circulation through the motor section of the pump. If, at anytime during operation the rear bearing housing appears overheated, check the temperature of the fluid being pumped. Check rear bearing housing temperature with a thermocouple to assure that it does not exceed the pumped fluid temperature by more than 15° F. (Assuming that no auxiliary means of cooling the recirculation flow is used, such as heat exchangers, jacketed circulation tubes, etc.) Rear bearing housing temperature can be checked by using a pyrometer or a standard thermometer held against the retainer by putty.

If the fluid temperature is satisfactory, overheating is most probably caused by a restriction in the circulation system.

Shutdown pump, drain unit, remove the circulation tube and clean it with clean, oil-free, compressed air. If the unit still runs hot or if tube was clear, the discharge filter may be clogged. Disconnect pipe connection and inspect.

CAUTION:

Between cycles of pumping fluids which may solidify, such as caustic soda, flush the system with steam, water or the proper solvent to prevent the piping and internal passages of the pump from plugging up. Where the Chempump is fitted with a discharge filter, flush pump during off cycles and check discharge filter for plugging.

4-8. Service Policy

Any Chempump, damaged or inoperative for any reason, will be repaired at the factory at minimum cost and returned to the customer as quickly as possible.

CAUTION:

Before returning units to the factory for examination or repair, CLEAN AND DECONTAMINATE THE PUMP OR PARTS THOROUGHLY TO PREVENT CORROSIVE ATTACK DURING SHIPMENT OR INJURY TO PERSONNEL HANDLING RETURNED EQUIPMENT.

TAG PUMP WITH INFORMATION REGARDING THE FLUID IT WAS HANDLING AND OPERATING CONDITIONS AT THE TIME OF FAILURE. Proper service will be facilitated with the proper submittal of a Chempump Field Service Report Form. These forms are available from the factory, from the Chempump field representatives, and from this instruction manual Appendix.

4-9. Spare Parts

Have on hand at least two extra sets of bearings, two extra sets of "O" rings, and one extra rotor assembly for each NC Series Chempump that is installed. When ordering spare parts, give the serial number and model designation; then give the part name which is noted on Cross Section Drawing D-65188, Page A - 10.

When ordering an impeller, include the impeller diameter which can be noted from the pump order acknowledgment or from the pump nameplate.

It is recommended that the following parts be maintained as "on-hand" spare parts for each NC Series Chempump model installed:

Please note, spare part kits that include all the components listed below packaged together are available. Please contact your Chempump representative/distributor or contact the factory for more information.

<u>Part</u>	<u>Quantity</u>
Pump Casing "O" Ring	2
Adapter "O" Ring	2
Rear Bearing Housing "O" Ring	2
Shaft Sleeve "O" Ring	2 sets
Shaft Sleeves	2 sets
Thrust Washers	2 sets
Thrust Washer key	2 sets
Bearings	2 sets
Impeller Nut, Key & Lockwasher	2 sets
Bearing Retaining Screw	2 sets

Table 4-2. Coil Resistance Values

MOTOR SIZE	VOLTAGE	INSULATION CLASS	*RESISTANCE (ohms)	MAX OHMVAR (MOTOR-MOTOR) (+/-)
N1	575	R	3.46	0.28
	460	R	2.22	0.18
	230	R	0.55	0.05
	208	R	0.45	0.04
N2	575	R	2.23	0.18
	460	R	1.46	0.12
	230	R	0.37	0.03
	208	R	0.30	0.02
N3	575	R	1.23	0.10
	460	R	0.79	0.06
	230	R	0.20	0.02
	208	R	0.16	0.01
N4	575	R	0.86	0.07
	460	R	0.55	0.04
	230	R	0.14	0.01
	208	R	0.11	0.01
N5	575	R	0.45	0.04
	460	R	0.29	0.02
	230	R	0.07	0.01
	208	R	0.06	0.01

* Resistance values at 25° C

Table 4-3. Trouble Shooting

TROUBLE	CAUSE	REMEDY
I. Failure to Deliver Required Capacity	<ul style="list-style-type: none"> a. Pump not primed. b. Air leaks in suction piping. c. Motor not energized. d. Motor windings burnt-out or grounded. e. Low suction head. f. Discharge head too high. g. Discharge valve closed or partially open. h. Impeller clogged. i. Wrong direction of rotation. j. Damaged impeller. 	<ul style="list-style-type: none"> a. Reprime pump in accordance with Paragraph 3-2, Page 3-1. b. Locate leaks and eliminate. c. Check motor wiring. See Paragraph 2-3, Page 2-3. d. Check electrical continuity of windings and if negative response, stator assembly needs to be replaced. e. Correct suction side of system to insure availability of design NPSH. f. Correct discharge side of system to insure proper operating conditions. g. Open discharge valve until rated discharge pressure is obtained. h. Remove obstructions in the impeller. i. Reverse any two motor leads and check with phase sequence meter. See Paragraph 3-3, Page 3-1. j. Impeller must be replaced.
II. Insufficient Pressure	<ul style="list-style-type: none"> a. Pump not primed. b. Air leaks in suction piping. c. Motor not energized. d. Motor windings burnt-out or grounded. e. Low suction head. f. Discharge valve open too wide. g. Impeller clogged. h. Wrong direction of rotation. i. Damaged impeller. 	<ul style="list-style-type: none"> a. Reprime pump in accordance with Paragraph 3-2, Page 3-1. b. Locate leaks and eliminate. c. Check motor wiring. See Paragraph 2-3, Page 2-3. d. Check electrical continuity of windings and if negative response, stator assembly needs to be replaced. e. Correct suction side of system to insure availability of design NPSH. f. Close down discharge valve until rated discharge pressure is obtained. g. Remove obstructions in the impeller. h. Reverse any two motor leads and check with phase sequence meter. See Paragraph 2-3, Page 2-3. i. Impeller must be replaced.
III. Pump loses Prime after Starting	<ul style="list-style-type: none"> a. Pump not properly primed at starting. b. Air leaks in suction piping. c. Air of gas in fluid. d. Low suction head. 	<ul style="list-style-type: none"> a. Reprime pump in accordance with Paragraph 3-2. b. Locate leaks and eliminate. c. Locate source of gas or air entrainment and correct. d. Correct suction side of system to insure availability of design NPSH.
IV. Pump Takes Too Much Power	<ul style="list-style-type: none"> a. Shaft bent. b. Rotating element binds. c. Electrical short. d. Wrong direction of rotation. 	<ul style="list-style-type: none"> a. Rotor assembly must be replaced. b. Replace bearings (see Paragraph 4-2, Page 4-2) as a result of excessive wear, or check for presence of foreign material in rotor chamber. c. Check electrical continuity of all phases of the motor. d. Reverse any two motor leads and check with phase sequence meter. See Paragraph 3-3, Page 3-1.
V. Pump Vibrates	<ul style="list-style-type: none"> a. Foundation not sufficiently rigid. b. Impeller partially clogged, causing unbalance. c. Shaft bent. d. Worn bearings. e. Rotating element rubbing stator liner. 	<ul style="list-style-type: none"> a. Tighten all bolts involved with the pump base and base supporting structure. b. Impeller partially clogged, causing unbalance - Remove obstructions in the impeller. c. Replace rotor assembly or straighten shaft if bend is not too great. d. Replace bearings (see Paragraph 4-1, Page 4-1). e. Replace bearings (See Paragraph 4-1, Page 4-1) as a result of excessive wear or check for presence of foreign material in rotor chamber.
VI. Motor Running Hot	<ul style="list-style-type: none"> a. If jacketed, no coolant flow circulating through jacket. b. Jacket clogged, preventing full circulation of coolant flow. c. Motor operating at overload condition. d. Plugged discharge filter (if pump is equipped with filter). e. Circulation tube crimped or bent. 	<ul style="list-style-type: none"> a. Turn on coolant flow. b. Shut down pump and flush jacket. (If jacket is removable type, remove from stator and flush). c. Make sure pump is operating at design point and conditions specified when purchased. d. Remove pump from line and flush. e. Replace with new tube (same size).

APPENDIX

CUSTOMER: _____ **DATE:** _____
ADDRESS: _____ **PHONE:** _____
 _____ **FAX:** _____
CONTACT: _____ **S/N #:** _____
E-MAIL: _____

Proper analysis of the trouble you have been experiencing requires an accurate description of operating conditions and the system in which the pump is installed.

DATE INSTALLED: _____ DATE REMOVED: _____ HOURS USED: _____

1.) LIQUID OR SOLUTION HANDLED
 (Include impurities or % if mixture): _____

IS DISSOLVED GAS PRESENT? _____

ARE SOLIDS IN SUSPENSION PRESENT? _____

IF SO, STATE NATURE: _____

2.) ACTUAL OPERATING CONDITIONS: TRANSFER CIRCULATION

FLOW: _____ GPM SUCTION PRESSURE: _____ PSIG

DISCHARGE PRESSURE: _____ PSIG DIFFERENTIAL: _____ PSI/FT.

PUMPING TEMPERATURE: _____ F SP. GR. @ P.T.: _____

VISCOSITY AT: _____ VAPOR PRESSURE AT: _____

PUMPING TEMPERATURE: _____ CPS PUMPING TEMPERATURE: _____ PSIA/MMHG

AMBIENT: _____ CPS AMBIENT: _____ PSIA/MMHG

3.) PLEASE SEND A SKETCH OF YOUR SYSTEM. GIVE A BRIEF DESCRIPTION, INCLUDING A ROUGH FLOW SHEET. INDICATE WHAT CHEMICAL OR PHYSICAL ACTION OCCURS BEFORE THE PUMP. SHOW COOLING OR HEATING SERVICES ON LINES DIRECTLY AFFECTING THE PUMP. SHOW WHAT CONTROLS ARE USED AND WHAT THEY OPERATE. IF MORE THAN ONE PUMP OPERATES ON A COMMON SUCTION, SHOW HOW THEY ARE BALANCED.

*YOUR ATTENTION TO THIS REPORT IS GREATLY APPRECIATED.
 UPON RECEIPT AT CHEMPUMP, WE WILL EVALUATE THE FACTS
 SHOWN AND RETURN OUR RECOMMENDATIONS TO YOU.*

RETURN COMPLETED FORM TO:

CHEMPUMP FACTORY SERVICE CENTER
 959 MEARNS ROAD, WARMINSTER, PA 18974
 PHONE: (215) 343-6000 FAX: (267) 486-1037

CUSTOMER: _____
 ADDRESS: _____
 CONTACT: _____

DATE: _____
 PHONE: _____
 FAX: _____
 RMA #: _____

Please complete the items below. By providing this information, you will allow us to work as quickly and safely as possible.

PUMP MODEL: _____
 PART NUMBER: _____
 DATE PURCHASED: _____

SERIAL NUMBER: _____
 DATE INSTALLED: _____
 INDOOR / OUTDOOR: _____

REASON FOR RETURN: WARRANTY REQUEST FACTORY SERVICE

FAILURE INFORMATION:

- | | | |
|---|--|--|
| <input type="checkbox"/> Failure To Deliver Required Capacity | <input type="checkbox"/> Vibration | <input type="checkbox"/> Motor Burnout |
| <input type="checkbox"/> Loses Prime After Starting | <input type="checkbox"/> Bearing Failure | <input type="checkbox"/> Other: _____ |
| <input type="checkbox"/> Axial Wear Due To Thrust | <input type="checkbox"/> Insufficient Pressure | |

BRIEF DESCRIPTION OF PUMP FAILURE: _____

DECONTAMINATION INFORMATION

All pumps/parts must be completely decontaminated and all information in this section must be completed prior to shipment to our factory or service center. Shipments received without this documentation will not be accepted and will be returned to the point of shipment.

CHECK ONE OF THE FOLLOWING:

- | | |
|--|---|
| <input type="checkbox"/> The pump has been flushed by following steps A through A3 of the Chempump Flushing Procedure on page 2 of this form. No liner rupture is suspected. | <input type="checkbox"/> Both the complete pump and the stator assembly have been flushed by following steps A through B3 of the Chempump Flushing Procedure on page 2 of this form. The motor must be rewound. |
|--|---|

FLUID PUMPED: _____ FLUSHING FLUID: _____

Attach completed material safety data sheets (MSDS) for these fluids. If either fluid is proprietary, please attach a description of any characteristics that will assist Chempump in safe handling. Without detailed and complete information on the pumped fluid, we will not be able to process your order.

PROTECTION EQUIPMENT RECOMMENDED FOR SAFE HANDLING OF THE PROCESS FLUID: _____

DECONTAMINATION CERTIFIED BY: _____ DATE: _____

TITLE: _____ PHONE: _____

RETURN COMPLETED FORM AND PUMP/PART TO:

- | | |
|--|---|
| <input type="checkbox"/> CHEMPUMP FACTORY SERVICE CENTER
959 MEARNS ROAD, WARMINSTER, PA 18974
PHONE: (215) 343-6000 FAX: (267) 486-1037 | <input type="checkbox"/> CHEMPUMP MIDWEST SERVICE CENTER
STATE ROUTE 2, BELMONT, WV 26134
PHONE: (304) 684-2459 FAX: (304) 684-7593 |
|--|---|

FLUSHING PROCEDURES FOR CHEMPUMP PRODUCTS

THE FOLLOWING FLUSHING PROCEDURES ARE REQUIRED TO ALLOW FOR MAXIMUM REMOVAL OF PROCESS FLUIDS.

PART "A" — COMPLETE PUMP

- A1) WITH THE SUCTION FLANGE DOWN, INTRODUCE AN APPROPRIATE NEUTRALIZING FLUID THROUGH THE DISCHARGE FLANGE. FLUSH THE PUMP IN THIS MANNER FOR A SUFFICIENT TIME TO ALLOW FOR THE REMOVAL OF ALL PROCESS FLUID.
- A2) AGAIN, WITH THE SUCTION FLANGE DOWN, REMOVE THE CIRCULATION LINE (AND FITTING IF NECESSARY) AND INTRODUCE AN APPROPRIATE NEUTRALIZING FLUID TO THE REAR OF THE PUMP. FLUSH THE PUMP IN THIS MANNER FOR A SUFFICIENT TIME TO ALLOW FOR THE REMOVAL OF ALL PROCESS FLUID. ALSO FLUSH THE CIRCULATION LINE AND/OR HEAT EXCHANGER TUBING, AS REQUIRED.
- A3) AFTER FLUSHING AS SPECIFIED ABOVE, REMOVE AS MUCH OF THE NEUTRALIZING FLUID AS POSSIBLE USING COMPRESSED AIR OR INERT GAS.

PART "B" — STATOR ASSEMBLY (if equipped with a relief valve)

IF A STATOR LINER RUPTURE IS SUSPECTED, FOLLOW THIS SECTION TO FLUSH THE STATOR CAVITY.

CAUTION: IF THIS STEP IS FOLLOWED, THE MOTOR MUST BE REWOUND.

- B1) REMOVE THE RELIEF VALVE. INSERT A SCREWDRIVER INTO THE RELIEF VALVE ADAPTER AND PRY THE LISK FILTER TO ONE SIDE. REMOVE THE CONNECTION BOX FROM THE LEAD NIPPLE AND CHIP AWAY THE POTTING COMPOUND FROM THE LEAD NIPPLE.
- B2) POSITION THE STATOR ASSEMBLY WITH THE LEAD NIPPLE DOWN AND INTRODUCE AN APPROPRIATE NEUTRALIZING FLUID TO THE RELIEF VALVE ADAPTER. THE FLUID WILL EXIT THROUGH THE LEAD NIPPLE. FLUSH THE STATOR CAVITY IN THIS MANNER FOR A SUFFICIENT TIME TO ALLOW FOR THE REMOVAL OF ALL PROCESS FLUID AND STATOR OIL.
- B3) REMOVE AS MUCH OF THE NEUTRALIZING FLUID AS POSSIBLE BY PURGING THE STATOR CAVITY WITH COMPRESSED AIR OR INERT GAS FOR 3 - 5 MINUTES.

PUMP CASING	D-59306	SIZE	1-1/2 X 1 X 6	MODEL	NC-AA-6
IMPELLER	D-59303	IMP. EYE AREA	3.142 sq. in.	RPM	ACTUAL (3450 Typical)
SERIAL #		IMP. DIA.	RANGE		

Curves are based on shop test while handling clean water at 20°C and at sea level. Performance guarantees apply at rating point only. Efficiencies shown are pump hydraulic. Numbers beneath model designations indicate full load horsepower ratings for the referenced motor load lines. When pumping fluids with specific gravities other than 1.0, select pump model (see load line) to handle load equivalent in feet of water, e.g. 40 feet of fluid of Sp. Gr.=1.5 is load equivalent of 60 feet (1.5x40) of water. Please note that this is merely a short cut method to estimate the model required. For proper model selection, especially when handling a fluid with a Sp. Gr. greater than 1.7, consult your Chempump representative or the factory.

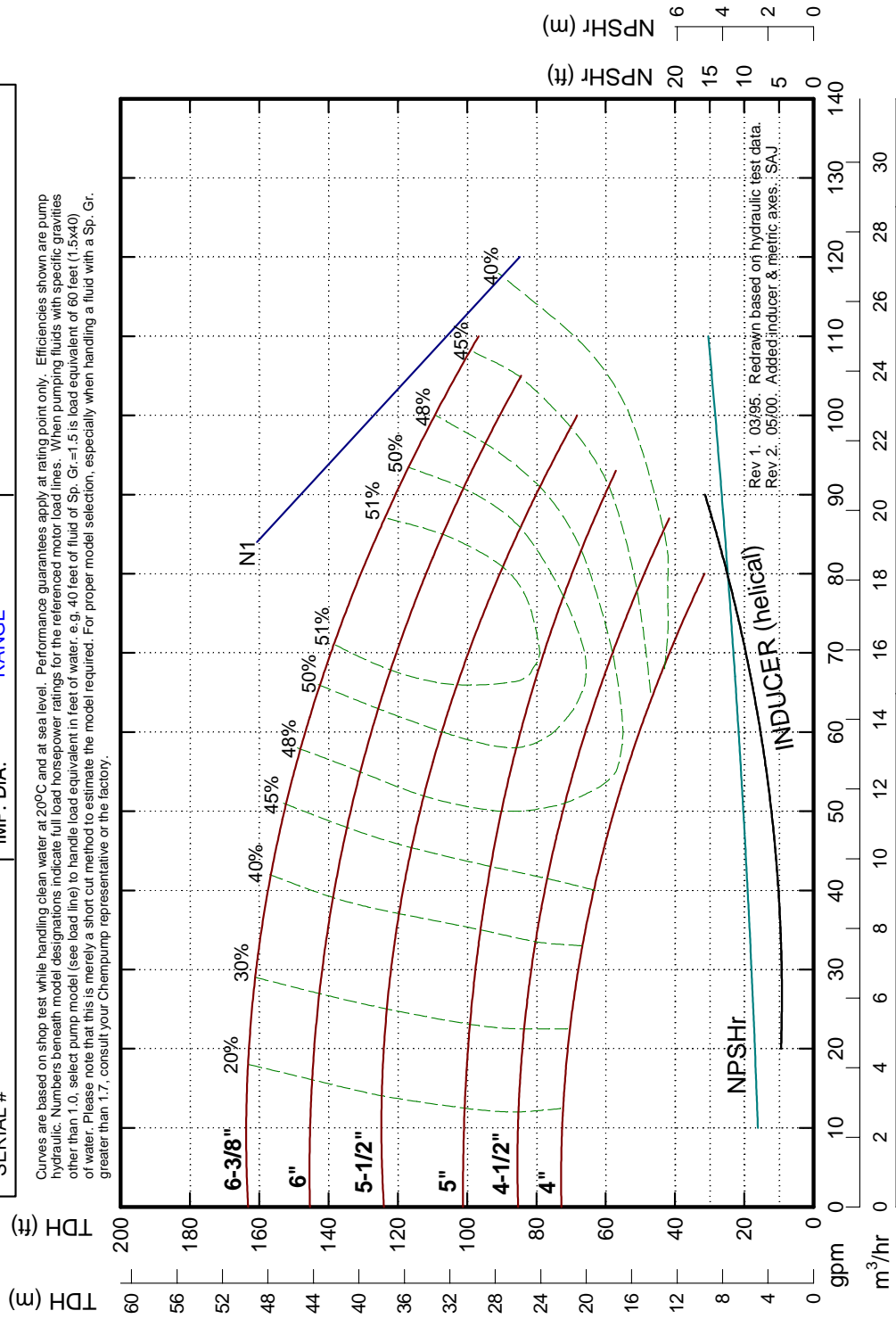

Rev 1. 03/95: Redrawn based on hydraulic test data.
 Rev 2. 05/00: Added inducer & metric axes., SAJ

 CHEMPUMP A DIVISION OF TEIKOKU USA INC. www.chempump.com www.teikoku-usa.com	DRAWN	DATE	CURVE	REV.
	WAF	2-16-94	A-70130	2

PUMP CASING	D-59307	SIZE	3 X 1-1/2 X 6	MODEL	NC-AB
IMPELLER	C-59304	IMP. EYE AREA	4,908 sq. in.	RPM	ACTUAL (3450 Typical)
SERIAL #		IMP. DIA.	RANGE		

Curves are based on shop test while handling clean water at 20°C and at sea level. Performance guarantees apply at rating point only. Efficiencies shown are pump hydraulic. Numbers beneath model designations indicate full load horsepower ratings for the referenced motor load lines. When pumping fluids with specific gravities other than 1.0, select pump model (see load line) to handle load equivalent in feet of water, e.g. 40 feet of fluid of Sp. Gr.=1.5 is load equivalent of 60 feet (1.5x40) of water. Please note that this is merely a short cut method to estimate the model required. For proper model selection, especially when handling a fluid with a Sp. Gr. greater than 1.7, consult your Chempump representative or the factory.

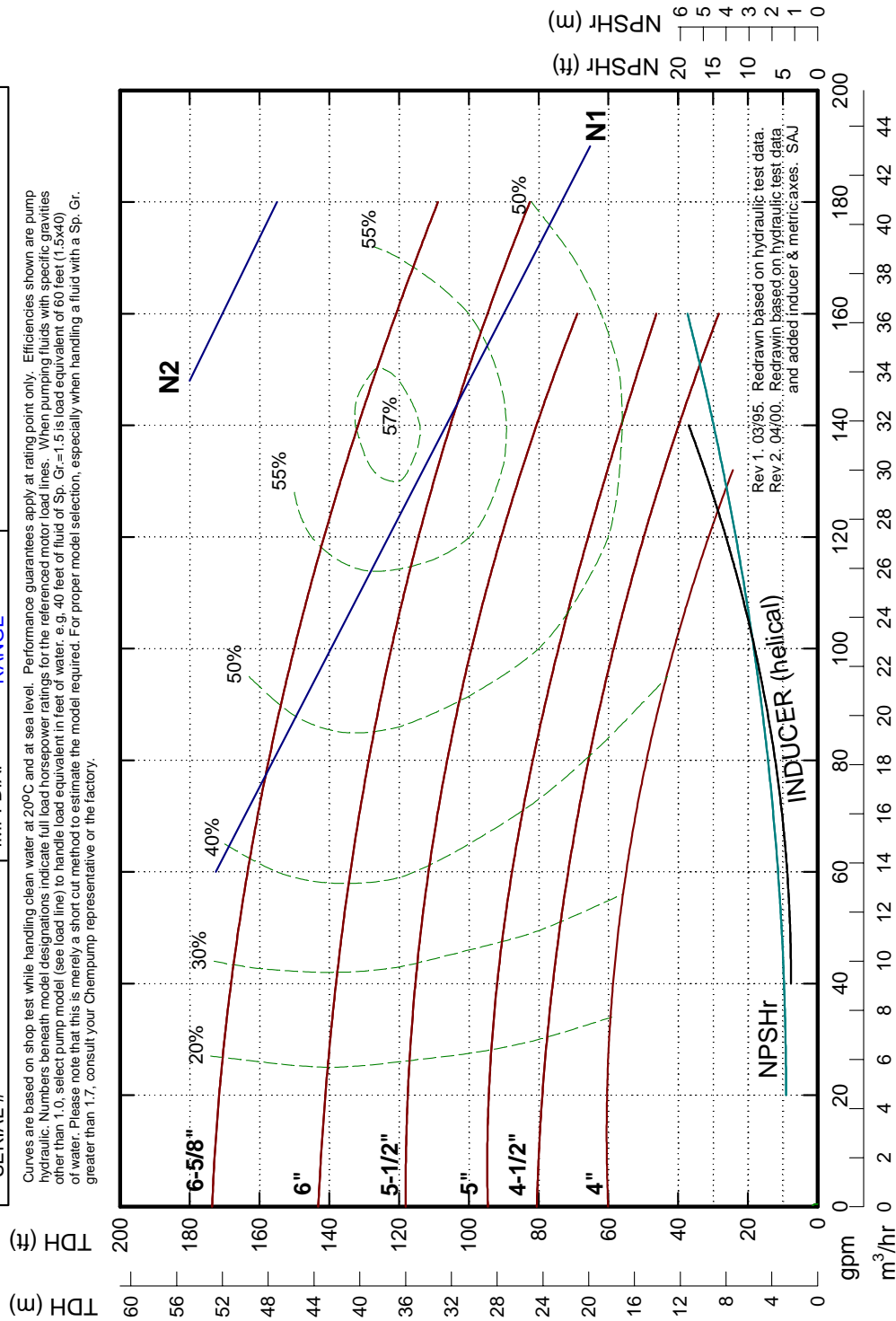

Rev 1. 03/95. Redrawn based on hydraulic test data.
 Rev 2. 04/00. Redrawn based on hydraulic test data,
 and added inducer & metric axes. SAJ

 CHEMPUMP A DIVISION OF TEIKOKU USA INC. www.chempump.com www.teikoku-usa.com	DRAWN	DATE	CURVE	REV.
	WAF	3-3-94	A-70131	2

Customer:	SIZE	1-1/2 X 1 X 8	MODEL	NC-AA-8-N3-3S
P.O. No.:	IMP. EYE AREA	3.547 sq. in.	RPM	ACTUAL (3450 Typical)
Serial No.:	IMP. DIA.	7 1/4"	Equip N0(s):	

Curves are based on shop test while handling clean water at 20°C and at sea level. Performance guarantees apply at rating point only. Efficiencies shown are pump hydraulic. Numbers beneath model designations indicate full load horsepower ratings for the referenced motor load lines. When pumping fluids with specific gravities other than 1.0, select pump model (see load line) to handle load equivalent in feet of water. e.g. 40 feet of fluid of Sp. Gr.=1.5 is load equivalent of 60 feet (1.5x40) of water. Please note that this is merely a short cut method to estimate the model required. For proper model selection, especially when handling a fluid with a Sp. Gr. greater than 1.7, consult your Chempump representative or the factory.

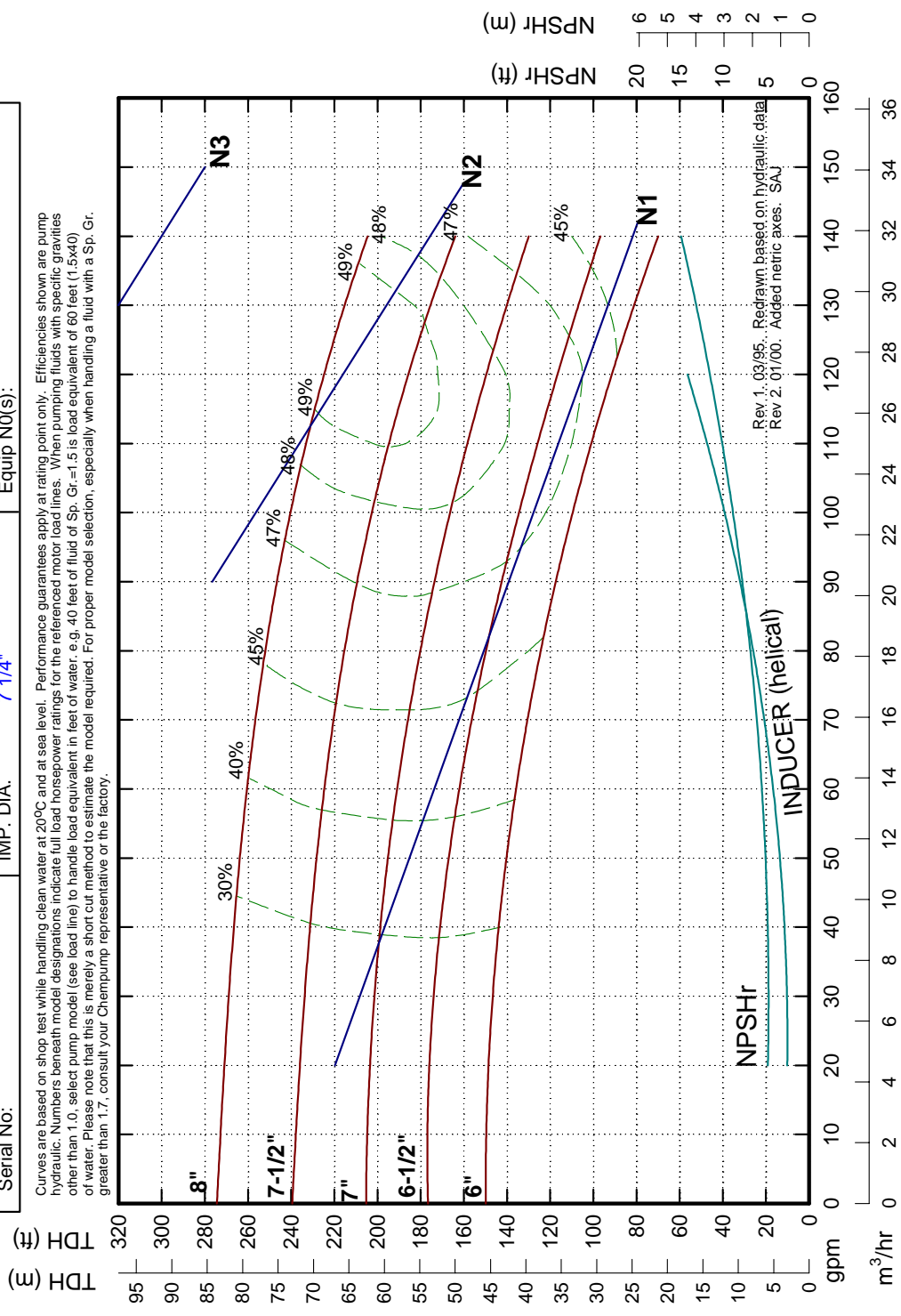

Rev 1. 03/95. Redrawn based on hydraulic data
 Rev 2. 01/00. Added metric axes. SAJ

 A DIVISION OF TEIKOKU USA INC. www.chempump.com www.teikoku-usa.com	DRAWN	DATE	CURVE	REV.
	WAF	2-22-94	A-70132	2

PUMP CASING	D-59327	SIZE	3 X 1-1/2 X 8	MODEL	NC-A50-8
IMPELLER	D-59325	IMP. EYE AREA	5.940 sq. in.	RPM	ACTUAL (3450 Typical)
SERIAL #		IMP. DIA.	RANGE		

Curves are based on shop test while handling clean water at 20°C and at sea level. Performance guarantees apply at rating point only. Efficiencies shown are pump hydraulic. Numbers beneath model designations indicate full load horsepower ratings for the referenced motor load lines. When pumping fluids with specific gravities other than 1.0, select pump model (see load line) to handle load equivalent in feet of water, e.g. 40 feet of fluid of Sp. Gr.=1.5 is load equivalent of 60 feet (1.5x40) of water. Please note that this is merely a short cut method to estimate the model required. For proper model selection, especially when handling a fluid with a Sp. Gr. greater than 1.7, consult your Chempump representative or the factory.

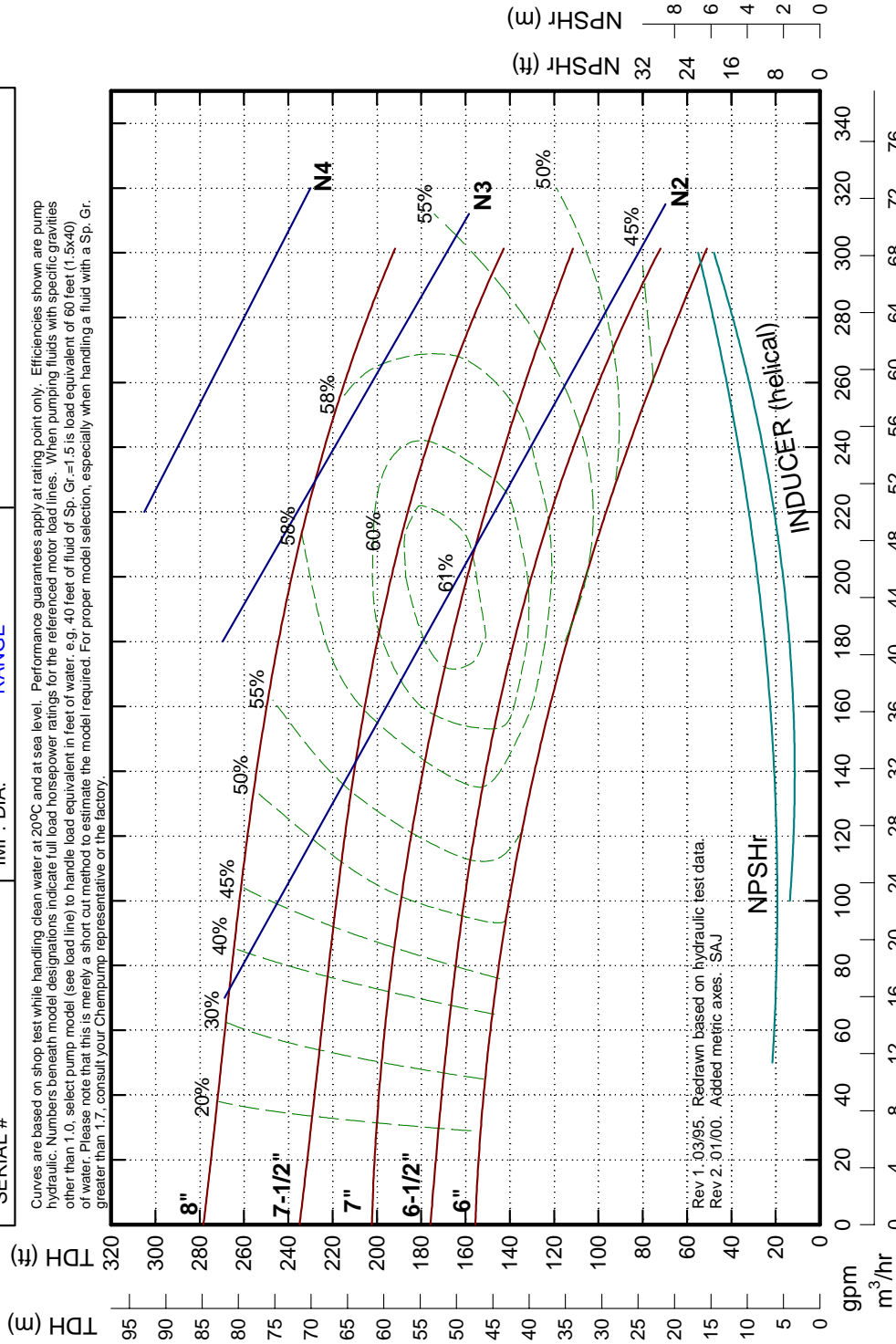

 A DIVISION OF TEIKOKU USA INC. www.chempump.com www.teikoku-usa.com	DRAWN	DATE	CURVE	REV.
	WAF	2-16-94	A-70133	2

PUMP CASING	D-59329	SIZE	3 X 2 X 8	MODEL	NC-A60-8
IMPELLER	D-59326	IMP. EYE AREA	7.366 sq. in.	RPM	ACTUAL (3450 Typical)
SERIAL #		IMP. DIA.	RANGE		

Curves are based on shop test while handling clean water at 20°C and at sea level. Performance guarantees apply at rating point only. Efficiencies shown are pump hydraulic. Numbers beneath model designations indicate full load horsepower ratings for the referenced motor load lines. When pumping fluids with specific gravities other than 1.0, select pump model (see load line) to handle load equivalent in feet of water, e.g. 40 feet of fluid of Sp. Gr.=1.5 is load equivalent of 60 feet (1.5x40) of water. Please note that this is merely a short cut method to estimate the model required. For proper model selection, especially when handling a fluid with a Sp. Gr. greater than 1.7, consult your Chem pump representative or the factory.

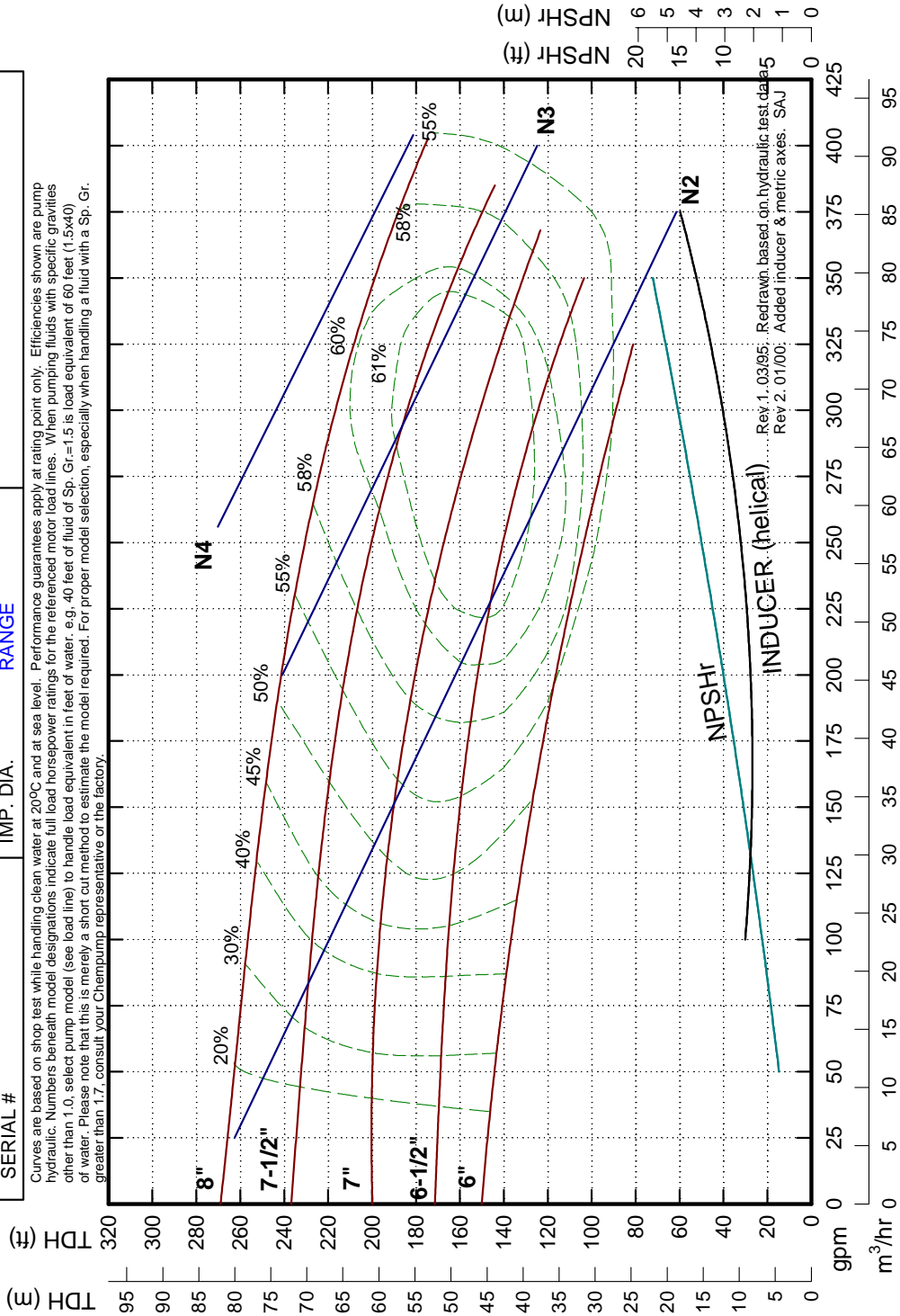

 A DIVISION OF TEIKOKU USA INC. www.chempump.com www.teikoku-usa.com	DRAWN	DATE	CURVE	REV.
	WAF	2-17-94	A-70134	2

PUMP CASING	D-59238	SIZE	2 X 1 X 10	MODEL	NC-A05
IMPELLER	D-59335	IMP. EYE AREA	5.204 sq. in.	RPM	ACTUAL (3450 Typical)
SERIAL #		IMP. DIA.	RANGE		

Curves are based on shop test while handling clean water at 20°C and at sea level. Performance guarantees apply at rating point only. Efficiencies shown are pump hydraulic. Numbers beneath model designations indicate full load horsepower ratings for the referenced motor load lines. When pumping fluids with specific gravities other than 1.0, select pump model (see load line) to handle load equivalent in feet of water, e.g. 40 feet of fluid of Sp. Gr. = 1.5 is load equivalent of 60 feet (1.5x40) of water. Please note that this is merely a short cut method to estimate the model required. For proper model selection, especially when handling a fluid with a Sp. Gr. greater than 1.7, consult your Chempump representative or the factory.

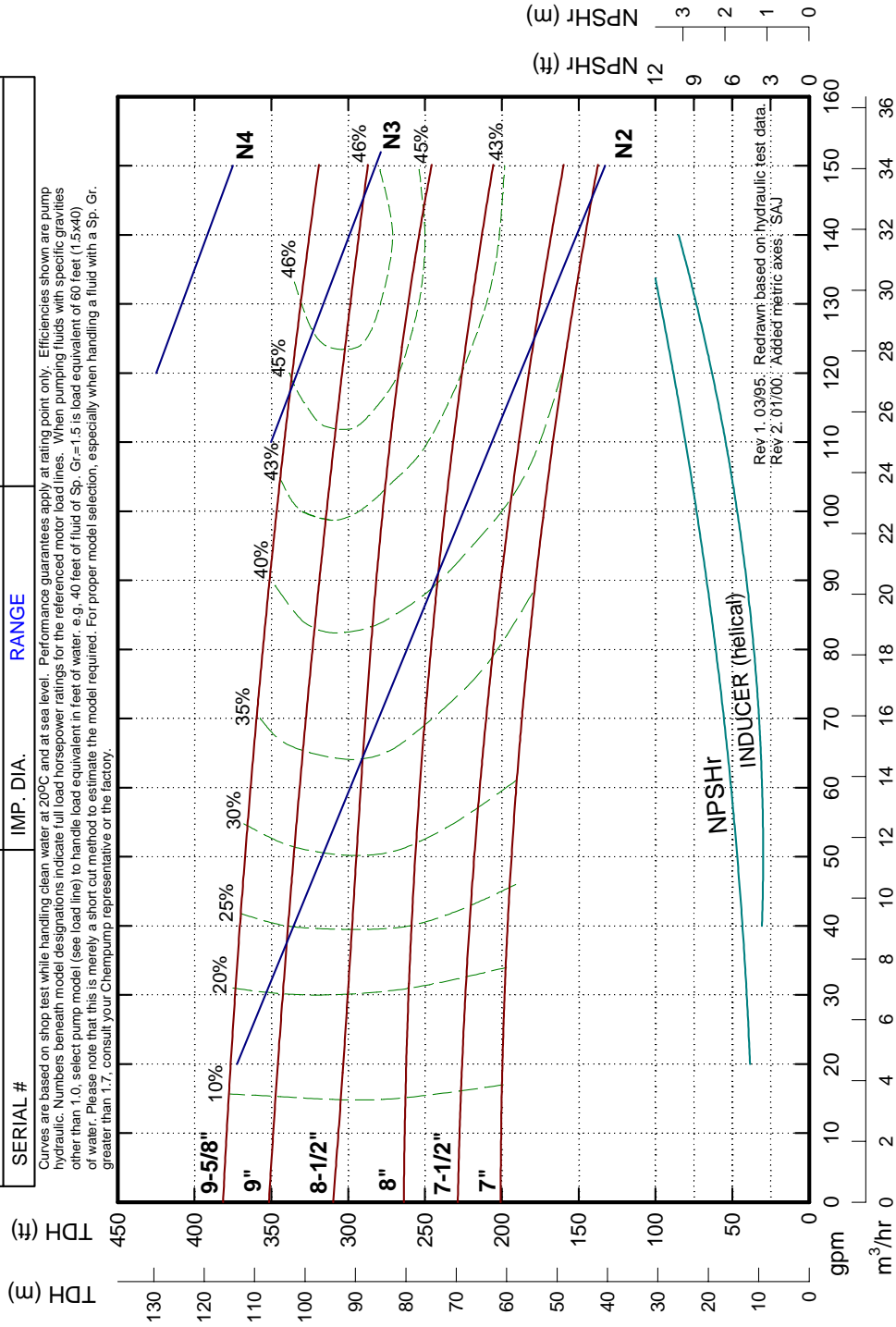

 A DIVISION OF TEIKOKU USA INC. www.chempump.com www.teikoku-usa.com	DRAWN	DATE	CURVE	REV.
	WAF	2-17-94	A-70135	2

PUMP CASING	D-59328	SIZE	3 X 1-1/2 X 10	MODEL	NC-A50-10
IMPELLER	D-59325	IMP. EYE AREA	5.940 sq. in.	RPM	ACTUAL (3450 Typical)
SERIAL #		IMP. DIA.	RANGE		

Curves are based on shop test while handling clean water at 20°C and at sea level. Performance guarantees apply at rating point only. Efficiencies shown are pump hydraulic. Numbers beneath model designations indicate full load horsepower ratings for the referenced motor load lines. When pumping fluids with specific gravities other than 1.0, select pump model (see load line) to handle load equivalent in feet of water, e.g. 40 feet of fluid of Sp. Gr.=1.5 is load equivalent of 60 feet (1.5x40) of water. Please note that this is merely a short cut method to estimate the model required. For proper model selection, especially when handling a fluid with a Sp. Gr. greater than 1.7, consult your Chempump representative or the factory.

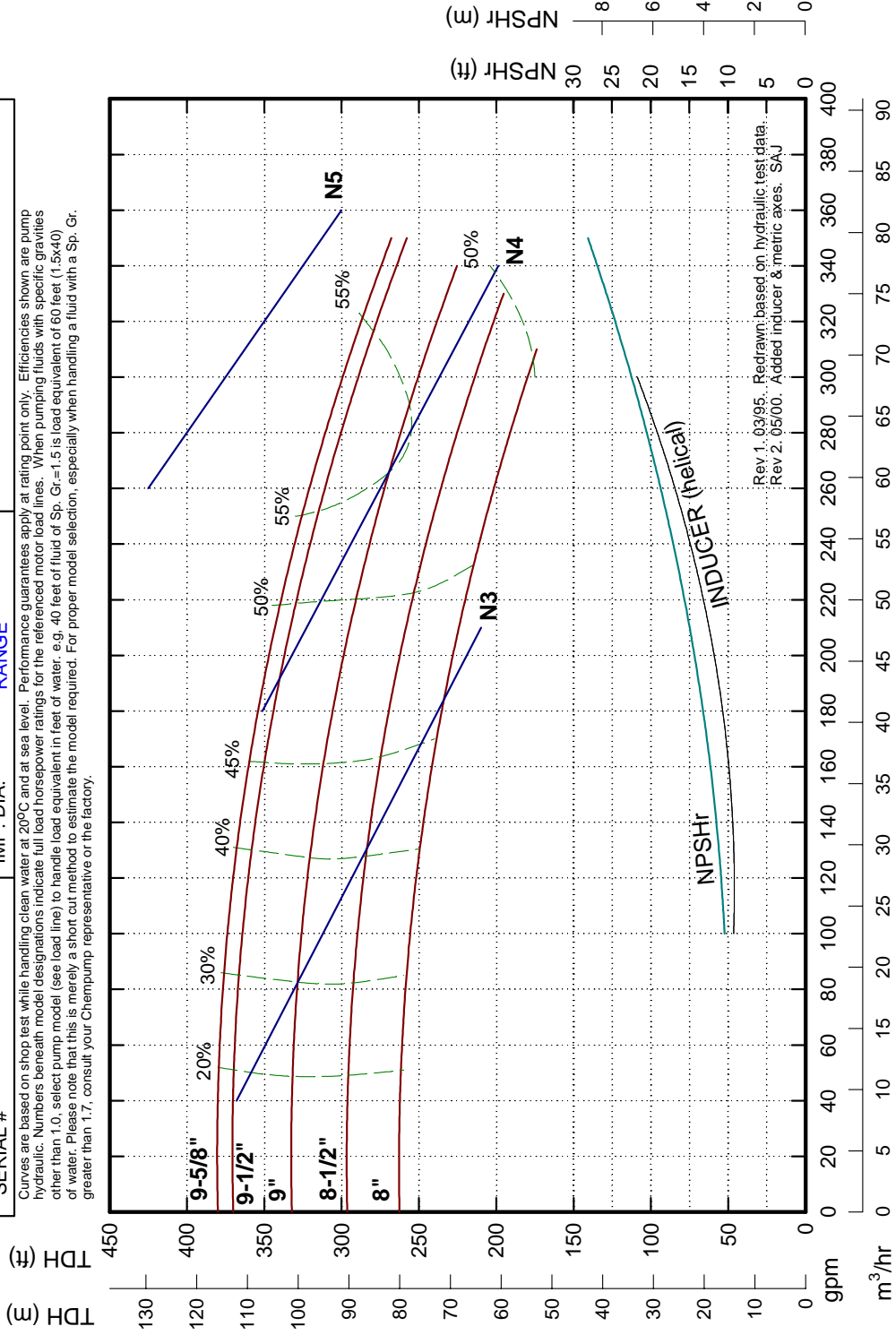

Rev 1: 03/95. Redrawn based on hydraulic test data.
 Rev 2: 05/00. Added inducer & metric axes. SAJ

 A DIVISION OF TEIKOKU USA INC. www.chempump.com www.teikoku-usa.com	DRAWN	DATE	CURVE	REV.
	WAF	2-17-94	A-70136	2

PUMP CASING	D-59330	SIZE	3 X 2 X 10	MODEL	NC-A60-10
IMPELLER	D-59326	IMP. EYE AREA	7.366 sq. in.	RPM	ACTUAL (3450 Typical)
SERIAL #		IMP. DIA.	RANGE		PRELIMINARY

Curves are based on shop test while handling clean water at 200C and at sea level. Performance guarantees apply at rating point only. Efficiencies shown are pump hydraulic. Numbers beneath model designations indicate full load horsepower ratings for the referenced motor load lines. When pumping fluids with specific gravities other than 1.0, select pump model (see load line) to handle load equivalent in feet of water: e.g. 40 feet of fluid of Sp. Gr.= 1.5 is load equivalent of 60 feet (1.5x40) of water. Please note that this is merely a short cut method to estimate the model required. For proper model selection, especially when handling a fluid with a Sp. Gr. greater than 1.7, consult your Chemump representative or the factory.

TDH (m)
TDH (ft)

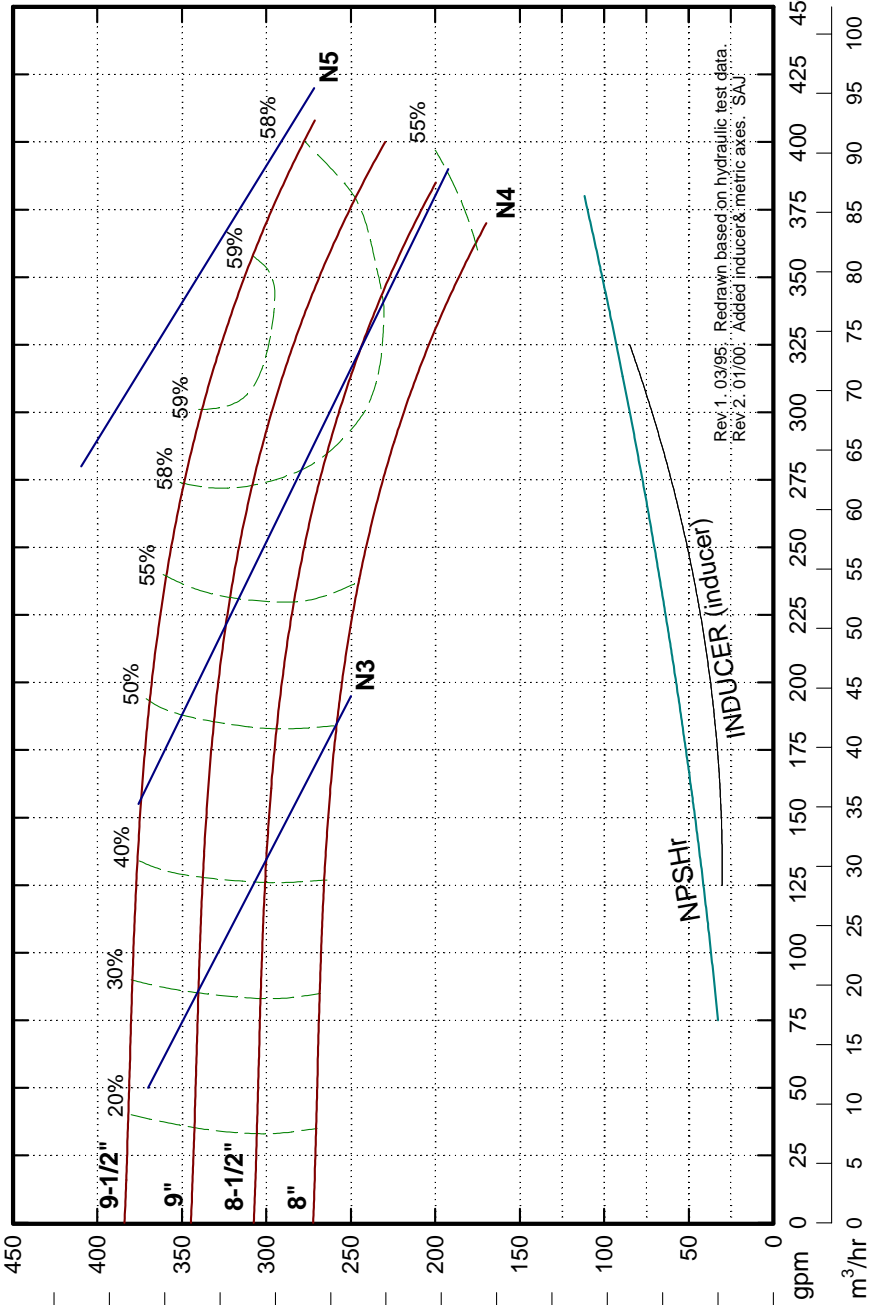

NPSH (ft)
NPSH (m)

 CHEMPUMP A DIVISION OF TEIKOKU USA INC. www.chempump.com www.teikoku-usa.com	DRAWN	DATE	CURVE	REV.
WAF	3-3-94	A-70137	2	

ITEM QTY.	DESCRIPTION
1	1 PUMP CASING (REF. DR. F.F. FLANGES)
2	1 KEY, IMPELLER
3	1 CIRCULATION LINE
4	1 NUT, IMPELLER
5	1 PUMP CASING ADAPTER
6	1 FILTER ASSEMBLY (OPTIONAL)
7	1 IMPELLER
8	8 O-RING, SHAFT SLEEVE
9	2 BEARING
10	10 SCREW, PUMP CASING
11	2 SCREW, BASE CRABLE
12	1 O-RING, PUMP CASING
13	2 THRUST WASHER
14	8 SCREW, PUMP CASING ADAPTER
15	1 CONNECTION BOX
16	1 ROTOR ASSEMBLY
17	2 KEY, SHAFT SLEEVE
18	1 STATOR ASSEMBLY
19	1 NAMEPLATE WITH SERIAL NO.
20	2 SLEEVE, SHAFT
21	1 HOUSING, REAR BEARING
22	2 SCREW, BEARING
23	1 O-RING, REAR BEARING HOUSING
24	6 SCREW, REAR BEARING HOUSING
25	1 RETAINER, SHAFT SLEEVE
26	2 FITTING, TUBE
27	1 O-RING, PUMP CASING ADAPTER
28	1 BASE CRABLE
29	1 LOCKWASHER, IMPELLER
30	1 CONN. BOX, INTELLISENSE
31	1 BASE FOOT (SOME MODELS)
32	2 SCREW, BASE FOOT (SOME MODELS)
33	1 BASE TAB
34	2 SCREW, BASE TAB
35	2 NUT, BASE TAB
36	1 DIRECTION OF ROTATION INDICATOR
37	1 LOCKNUT 3/4 NPT
38	1 TRANSFORMER
39	4 SCREW, TRANSFORMER
40	1 CRIMP HOUSING
41	5 CRIMP TERMINAL
42	1 SWITCH, INTELLISENSE CUT-OFF
43	1 FUSE
44	1 NIPPLE

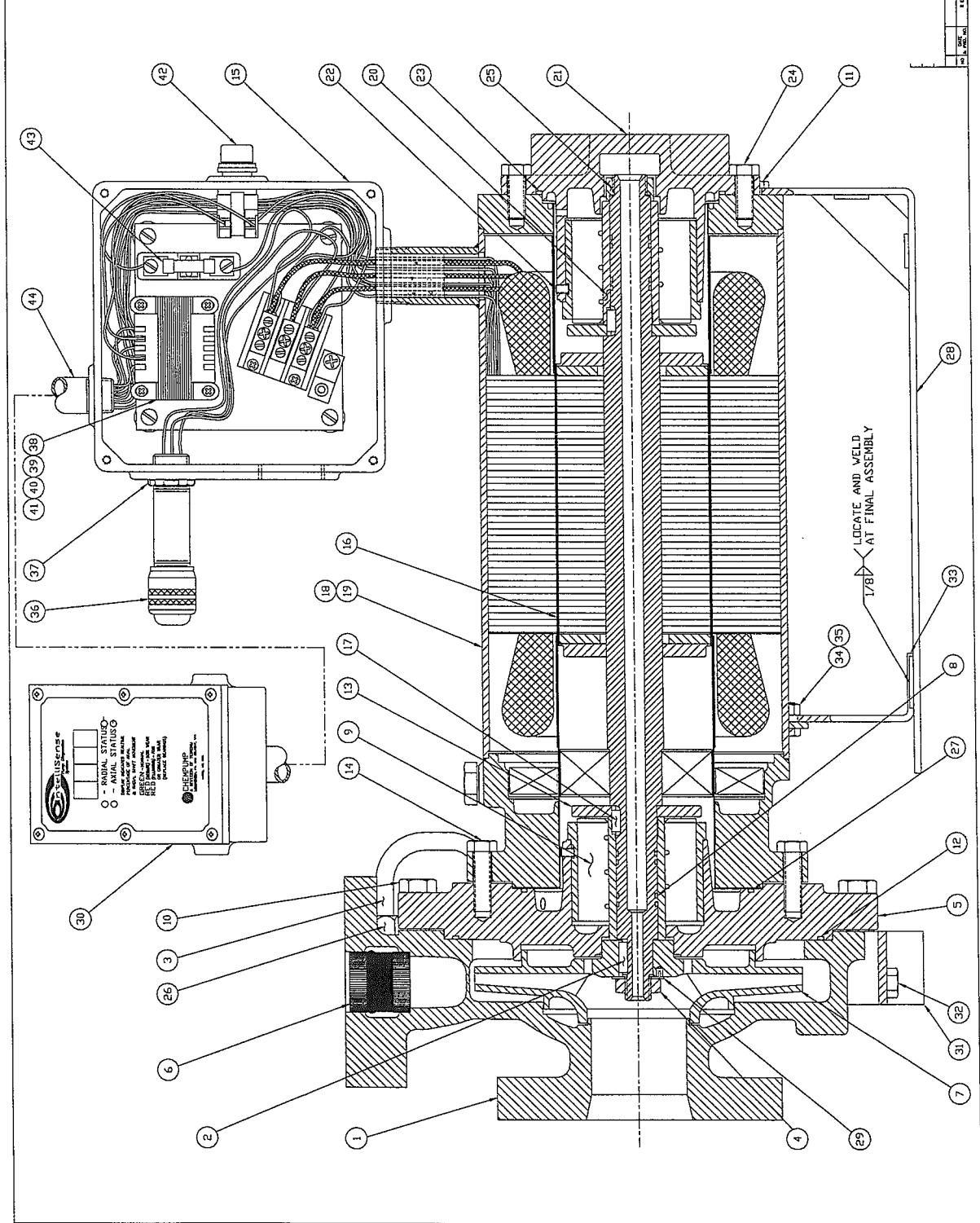

NOTE:
REFERENCE SERIAL NUMBER WHEN
ORDERING PARTS

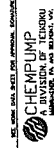

CHEMPUMP
A DIVISION OF
MILWAUKEE ELECTRIC
CORPORATION
MILWAUKEE, WISCONSIN
U.S.A.

CROSS SECTION
TYPICAL
NC SERIES

3 of 3
D 65209 0

AA	1-1/2x1x8	15 11/16[399]	19 7/16[494]	24 7/8[632]	16 1/8[410]	20 7/16[519]	25 7/8[657]	17 1/8[435]	22 11/16[576]	28 1/8[714]	19 3/8[492]	24 3/16[614]	29 5/8[753]	20 7/8[530]
AB	3x1-1/2x6	15 3/16[386]	19 1/16[484]	24 1/2[622]	15 3/4[400]	20 1/16[510]	25 1/2[648]	16 3/4[425]	22 5/16[567]	27 3/4[705]	19 1/4[483]	23 13/16[605]	29 1/4[743]	20 1/2[521]
AA	1-1/2x1x6	15 3/16[386]	19 1/16[484]	24 1/2[622]	15 3/4[400]	20 1/16[510]	25 1/2[648]	16 3/4[425]	22 5/16[567]	27 3/4[705]	19 1/4[483]	23 13/16[605]	29 1/4[743]	20 1/2[521]
ANSI SIZE	SUCTION-DISCHARGE x IMPELLER DIAMETER	A	B	C	G	B	C	G	B	C	G	B	C	G
		N1 MOTOR			N2 MOTOR			N3 MOTOR			N4 MOTOR			

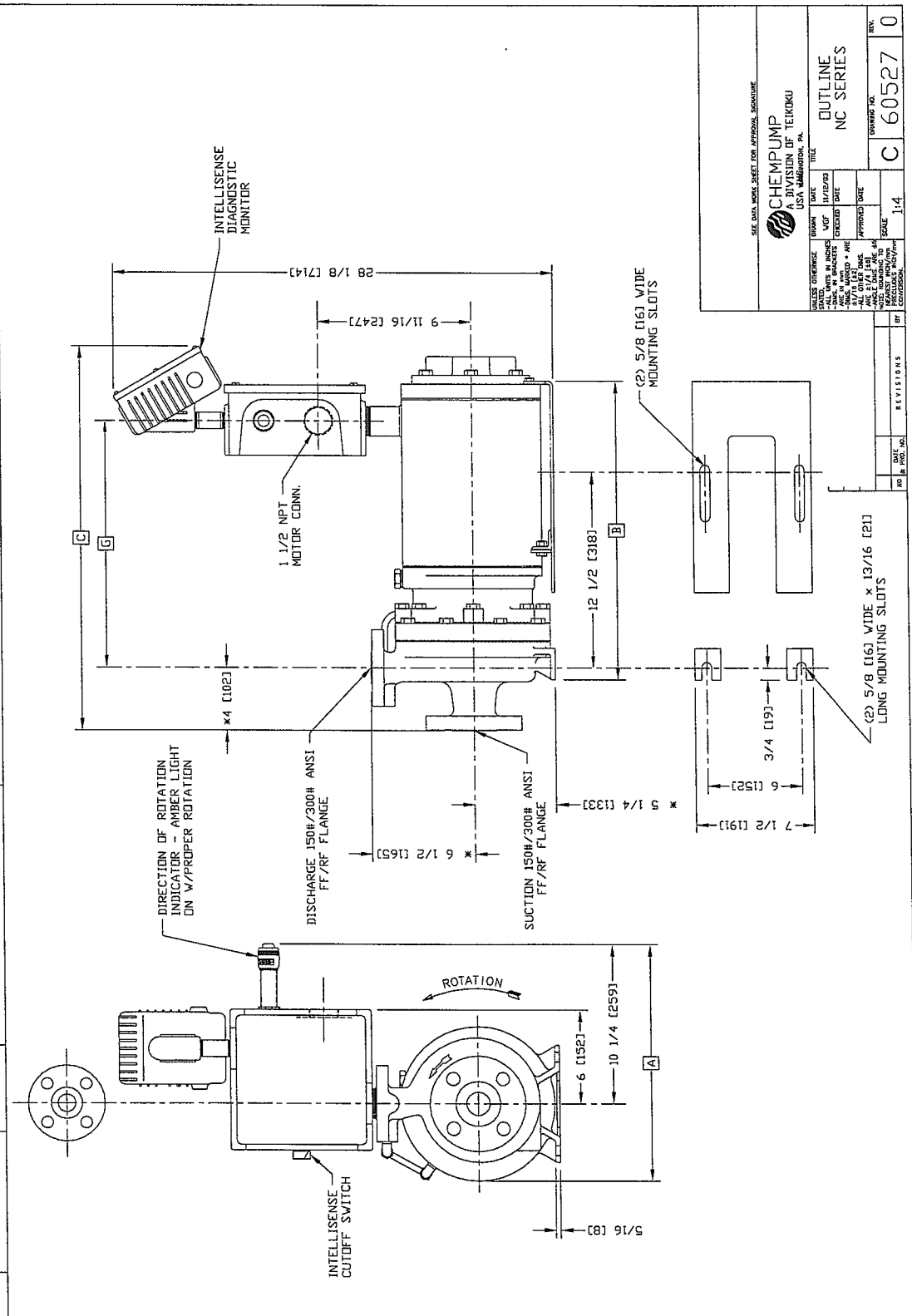

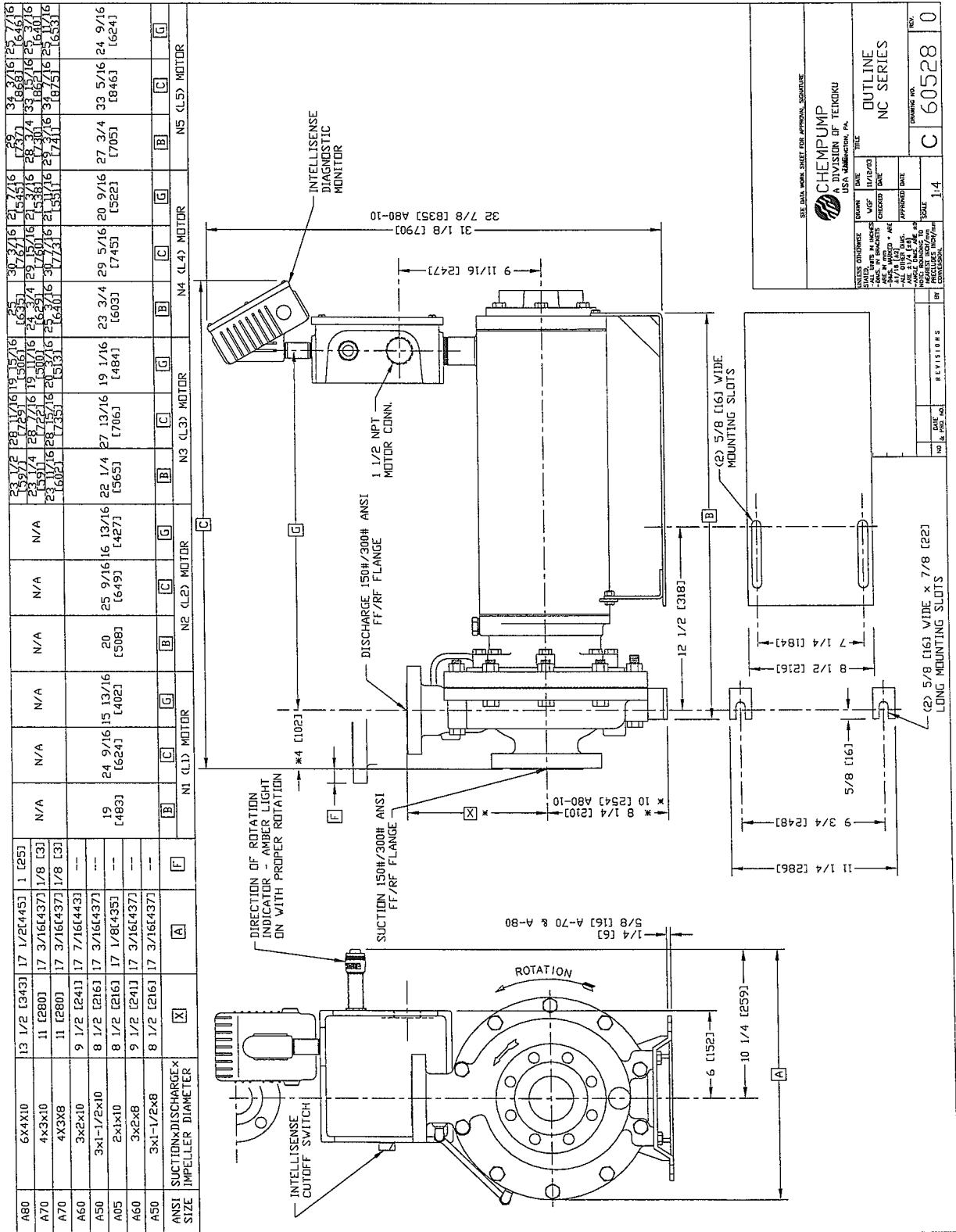

ANSI IMPELLER DIAMETER X SIZE	A	F	N1 (L1) MOTOR	N2 (L2) MOTOR	N3 (L3) MOTOR	N4 (L4) MOTOR	N5 (L5) MOTOR
A80	13 1/2 [343]	17 1/2 [445]	1 [25]	N/A	N/A	23 1/2 [591]	31 1/2 [791]
A70	11 [280]	17 3/16 [437]	1/8 [3]	N/A	N/A	21 1/4 [540]	29 1/2 [743]
A60	9 1/2 [241]	17 7/16 [443]	---	N/A	N/A	19 1/16 [484]	27 1/4 [695]
A50	8 1/2 [216]	17 3/16 [437]	---	19 [483]	25 9/16 [649]	23 3/4 [603]	31 1/8 [790]
A05	8 1/2 [216]	17 1/8 [435]	---	24 9/16 [624]	20 [508]	23 3/4 [603]	31 1/8 [790]
A60	9 1/2 [241]	17 3/16 [437]	---	24 9/16 [624]	20 [508]	23 3/4 [603]	31 1/8 [790]
A50	8 1/2 [216]	17 3/16 [437]	---	24 9/16 [624]	20 [508]	23 3/4 [603]	31 1/8 [790]

SEE DATA WORK SHEET FOR APPROVAL SIGNATURE

CHEMPUMP
A DIVISION OF TEROKU
USA Wilmington, PA.

DATE: 7/15/14
DRAWN BY: J. W. BAKER
CHECKED BY: J. W. BAKER
APPROVED DATE: 7/15/14

TITLE: **OUTLINE**
NC SERIES

SCALE: 1:1

REV. **0**
C **60528**



CHEMPUMP

A DIVISION OF TEIKOKU USA INC.

959 Mearns Road, Warminster, PA 18974 Phone: (215) 343-6000 Fax: (267) 486-1037 Website: www.chempump.com E-mail: chempump@chempump.com