

# SERVICE & OPERATING MANUAL

## Original Instructions

### Certified Quality



Quality System  
ISO 9001 Certified



Environmental Management System  
ISO 14001 Certified



Warren Rupp, Inc.  
A Unit of IDEX Corporation  
800 N. Main St.,  
Mansfield, Ohio 44902 USA  
Telephone 419.524.8388  
Fax 419.522.7867  
SANDPIPERPUMP.COM



© Copyright 2016 Warren Rupp, Inc.  
All rights reserved

# Model S05

## Metallic Design Level 1

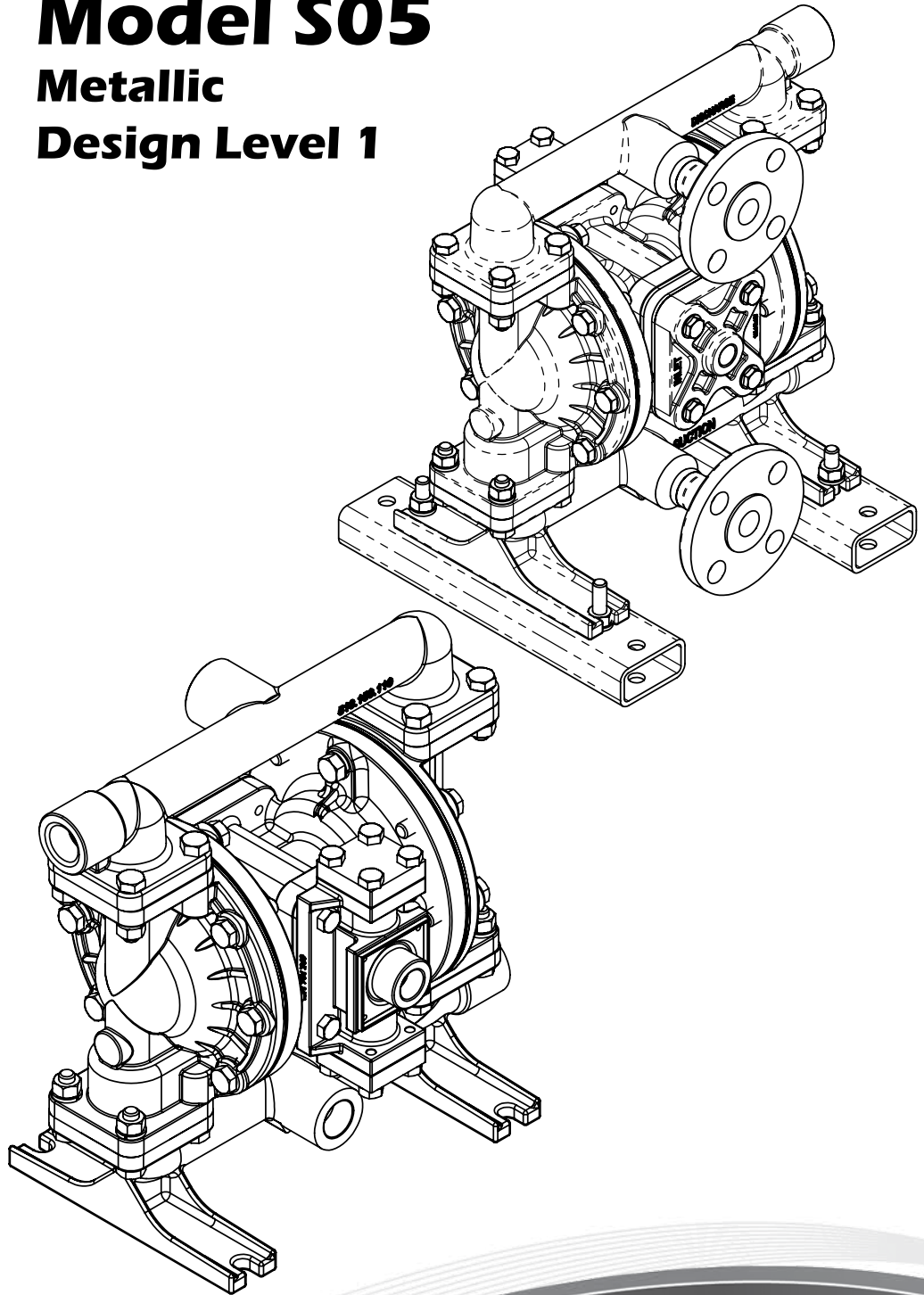

1: PUMP SPECS

2: INSTAL & OP

3: EXP VIEW

4: AIR END

5: WET END

6: OPTIONAL

7: WARRANTY

**SANDPIPER**<sup>®</sup>  
A WARREN RUPP, INC. BRAND

SANDPIPERPUMP.COM

# Safety Information

## IMPORTANT



Read the safety warnings and instructions in this manual before pump installation and start-up. Failure to comply with the recommendations stated in this manual could damage the pump and void factory warranty.



When the pump is used for materials that tend to settle out or solidify, the pump should be flushed after each use to prevent damage. In freezing temperatures the pump should be completely drained between uses.

## CAUTION



Before pump operation, inspect all fasteners for loosening caused by gasket creep. Retighten loose fasteners to prevent leakage. Follow recommended torques stated in this manual.



Nonmetallic pumps and plastic components are not UV stabilized. Ultraviolet radiation can damage these parts and negatively affect material properties. Do not expose to UV light for extended periods of time.



**WARNING**  
Pump not designed, tested or certified to be powered by compressed natural gas. Powering the pump with natural gas will void the warranty.

## WARNING



When used for toxic or aggressive fluids, the pump should always be flushed clean prior to disassembly.



Before maintenance or repair, shut off the compressed air line, bleed the pressure, and disconnect the air line from the pump. Be certain that approved eye protection and protective clothing are worn at all times. Failure to follow these recommendations may result in serious injury or death.



Airborne particles and loud noise hazards. Wear eye and ear protection.



In the event of diaphragm rupture, pumped material may enter the air end of the pump, and be discharged into the atmosphere. If pumping a product that is hazardous or toxic, the air exhaust must be piped to an appropriate area for safe containment.



Take action to prevent static sparking. Fire or explosion can result, especially when handling flammable liquids. The pump, piping, valves, containers and other miscellaneous equipment must be properly grounded.



This pump is pressurized internally with air pressure during operation. Make certain that all fasteners are in good condition and are reinstalled properly during reassembly.



Use safe practices when lifting

## Grounding ATEX Pumps

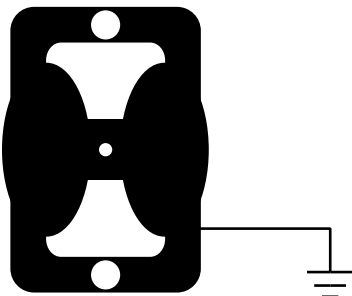

ATEX compliant pumps are suitable for use in explosive atmospheres when the equipment is properly grounded in accordance with local electrical codes. Pumps equipped with electrically conductive diaphragms are suitable for the transfer of conductive or non-conductive fluids of any explosion group. When operating pumps equipped with non-conductive diaphragms that exceed the maximum permissible projected area, as defined in EN 13461-1: 2009 section 6.7.5 table 9, the following protection methods must be applied:

- Equipment is always used to transfer electrically conductive fluids or
- Explosive environment is prevented from entering the internal portions of the pump, i.e. dry running

For further guidance on ATEX applications, please consult the factory.

# Table of Contents

## **SECTION 1: PUMP SPECIFICATIONS.....1**

- Explanation of Pump Nomenclature
- Performance
- Materials
- Dimensional Drawings

## **SECTION 2: INSTALLATION & OPERATION.....6**

- Principle of Pump Operation
- Recommended Installation Guide
- Troubleshooting Guide

## **SECTION 3: EXPLODED VIEW.....9**

- Composite Repair Parts Drawing
- Composite Repair Parts List
- Material Codes

## **SECTION 4: AIR END.....12**

- Air Distribution Valve Assembly
- Air Valve with Stroke Indicator Assembly
- Pilot Valve Assembly
- Intermediate Assembly

## **SECTION 5: WET END .....17**

- Diaphragm Drawings
- Diaphragm Servicing

## **SECTION 6: OPTIONAL CONFIGURATIONS....19**

- Solenoid Shifted Air Valve
- Dual Port

## **SECTION 7: WARRANTY & CERTIFICATES ....21**

- Warranty
- CE Declaration of Conformity - Machinery
- ATEX Declaration of Conformity

1: PUMP SPECS

2: INSTAL & OP

3: EXP VIEW

4: AIR END

5: WET END

6: OPTIONAL

7: WARRANTY

# Explanation of Pump Nomenclature

Your Model #: **S**

(fill in from pump nameplate)

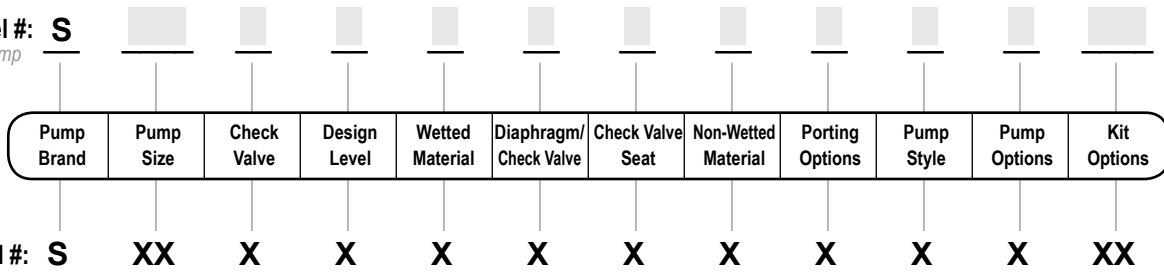

### Pump Brand

**S** SANDPIPER®

### Pump Size

**05** 1/2"

### Check Valve Type

**B** Solid Ball

### Design Level

**1** Design Level

### Wetted Material

- A** Aluminum
- S** Stainless Steel
- H** Alloy C
- X** Unpainted Aluminum

### Diaphragm/Check Valve Materials

- B** Nitrile/Nitrile
- C** FKM/PTFE
- N** Neoprene/Neoprene
- E** EPDM/EPDM
- U** Polyurethane
- 1** Santoprene®/Santoprene®
- 2** PTFE-Santoprene®/PTFE
- Z** One Piece PTFE-Nitrile/PTFE

### Check Valve Seat

- A** Aluminum
- C** Cast Iron
- H** Alloy C
- S** Stainless Steel
- T** PTFE
- W** UHMW Polyethylene

### Non-Wetted Material Options

- A** Aluminum
- Y** Aluminum With Stainless Steel hardware

### Non-Wetted Material Options (cont.)

- † **C** Conductive Polypropylene With Stainless Steel hardware
- † **P** Polypropylene With Stainless Steel hardware

### Porting Options

- N** NPT Threads
- B** BSP (Tapered) Threads
- 1** Dual Porting (NPT)
- 2** Top Dual Porting (NPT)
- 3** Bottom Dual Porting NPT
- 4** Dual Porting BSP (Tapered)
- 5** Top Dual Porting BSP (Tapered)
- 6** Bottom Dual Porting BSP (Tapered)
- R** 1/2" Raised Face #150 ANSI Flange with Threaded Pipe Connection
- W** 1/2" Welded Raised Face #150 ANSI Flanged Manifolds\*

### Pump Style

**S** Standard

### Pump Options

- 0** Integral Muffler
- 6** Metal Muffler

### Kit Options

- 00** None
- P0** 10.30VDC Pulse Output Kit
- P1** Intrinsically-Safe 5.30VDC, 110/120VAC 220/240 VAC Pulse Output Kit
- P2** 110/120 or 220/240VAC Pulse Output Kit
- E0** Solenoid Kit with 24VDC Coil

### Kit Options (cont.)

- E1** Solenoid Kit with 24VDC Explosion-Proof Coil
  - E2** Solenoid Kit with 24VAC/12VDC Coil
  - E3** Solenoid Kit with 12VDC Explosion-Proof Coil
  - E4** Solenoid Kit with 110VAC Coil
  - E5** Solenoid Kit with 110VAC Explosion-Proof Coil
  - E6** Solenoid Kit with 220VAC Coil
  - E7** Solenoid Kit with 220VAC Explosion-Proof Coil
  - E8** Solenoid Kit with 110VAC, 50 Hz Explosion-Proof Coil
  - E9** Solenoid Kit with 230VAC, 50 Hz Explosion-Proof Coil
  - SP** Stroke Indicator Pins
- 
- A1** Solenoid Kit with 12 VDC ATEX Compliant Coil
  - A2** Solenoid Kit with 24 VDC ATEX Compliant Coil
  - A3** Solenoid Kit with 110/120 VAC 50/60 Hz ATEX Compliant Coil
  - A4** Solenoid Kit with 220/240 VAC 50/60 Hz ATEX Compliant Coil

† Note: Pumps equipped with non-wetted options C or P are limited to a maximum operating pressure of 100 psi or 7 bar.



IEC EEX m T4



**Note:** Pump models equipped with these explosion-proof solenoid kit options E1, E3, E5, E7, E8 or E9, are certified and approved by the above agencies. They are NOT ATEX compliant.

Your Serial #: (fill in from pump nameplate) \_\_\_\_\_

**Special Conditions For Safe Use:** Conductive polypropylene, conductive acetal, or conductive PVDF pumps are not to be installed in applications where the pumps may be subjected to oil, greases and hydraulic liquids

## ATEX Detail

	ATEX Detail	Wetted Material Options	Non-Wetted Material Options	Pump Options	Kit Options
	II 1G c T5 II 1D c T100°C I M1 c I M2 c	H, S	C	6	00
	II 2G c T5 II 2D c T100°C	A, H, S	A, C, Y	**0, 6	00
	II 2G Ex ia c IIC T5 II 2D Ex c iaD 20 IP67 T100°C	A, H, S	A, C, Y	**0, 6	P1
	II 2G EEx m c II T5 II 2D c IP65 T100°C	A, H, S	A, C, Y	**0, 6	A1, A2, A3, A4

\*\*Pump option 0 is only ATEX compliant with non-wetted material option C

# Performance

## S05 METALLIC

### SUCTION/DISCHARGE PORT SIZE

- 1/2" NPT (Internal) or 1/2" BSP (Tapered)
- 1" NPT (External) or 1" BSP (Tapered)
- 1/2" Raised Face #150 ANSI Flanges - Stainless Steel ONLY

### CAPACITY

- 0 to 15 gallons per minute (0 to 56 liters per minute)

### AIR DISTRIBUTION VALVE

- No-lube, no-stall design

### SOLIDS-HANDLING

- Up to .125 in. (3mm)

### HEADS UP TO

- 125 psi or 289 ft. of water (8.6 bar or 86 meters)

### MAX OPERATING PRESSURE

- 125 psi (8.6 bar) metallic center
- 100 psi (7 bar) non-metallic center

### DISPLACEMENT/STROKE

- .026 Gallon / .098 liter

### SHIPPING WEIGHT

- Aluminum 15 lbs. (7kg)
- Stainless Steel 21 lbs. (10kg)

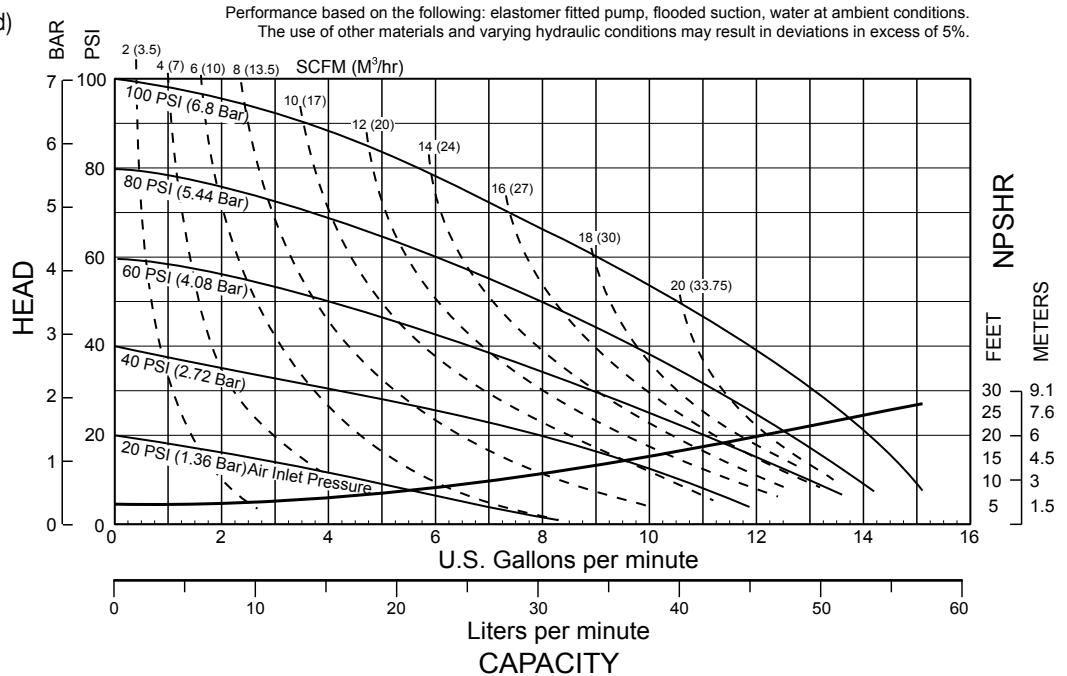

# Materials

Material Profile:	Operating Temperatures:	
	Max.	Min.
<b>Conductive Acetal:</b> Tough, impact resistant, ductile. Good abrasion resistance and low friction surface. Generally inert, with good chemical resistance except for strong acids and oxidizing agents.	190°F 88°C	-20°F -29°C
<b>EPDM:</b> Shows very good water and chemical resistance. Has poor resistance to oils and solvents, but is fair in ketones and alcohols.	280°F 138°C	-40°F -40°C
<b>FKM:</b> (Fluorocarbon) Shows good resistance to a wide range of oils and solvents; especially all aliphatic, aromatic and halogenated hydrocarbons, acids, animal and vegetable oils. Hot water or hot aqueous solutions (over 70°F(21°C)) will attack FKM.	350°F 177°C	-40°F -40°C
<b>Hytrel®:</b> Good on acids, bases, amines and glycols at room temperatures only.	220°F 104°C	-20°F -29°C
<b>Neoprene:</b> All purpose. Resistance to vegetable oils. Generally not affected by moderate chemicals, fats, greases and many oils and solvents. Generally attacked by strong oxidizing acids, ketones, esters and nitro hydrocarbons and chlorinated aromatic hydrocarbons.	200°F 93°C	-10°F -23°C
<b>Nitrile:</b> General purpose, oil-resistant. Shows good solvent, oil, water and hydraulic fluid resistance. Should not be used with highly polar solvents like acetone and MEK, ozone, chlorinated hydrocarbons and nitro hydrocarbons.	190°F 88°C	-10°F -23°C
<b>Nylon:</b> 6/6 High strength and toughness over a wide temperature range. Moderate to good resistance to fuels, oils and chemicals.	180°F 82°C	32°F 0°C

- Ambient temperature range:** -20°C to +40°C  
**Process temperature range:** -20°C to +80°C for models rated as category 1 equipment  
 -20°C to +100°C for models rated as category 2 equipment

In addition, the ambient temperature range and the process temperature range do not exceed the operating temperature range of the applied non-metallic parts as listed in the manuals of the pumps.

<b>Polypropylene:</b> A thermoplastic polymer. Moderate tensile and flex strength. Resists strong acids and alkali. Attacked by chlorine, fuming nitric acid and other strong oxidizing agents.	180°F 82°C	32°F 0°C
<b>PVDF:</b> (Polyvinylidene Fluoride) A durable fluoroplastic with excellent chemical resistance. Excellent for UV applications. High tensile strength and impact resistance.	250°F 121°C	0°F -18°C
<b>Santoprene®:</b> Injection molded thermoplastic elastomer with no fabric layer. Long mechanical flex life. Excellent abrasion resistance.	275°F 135°C	-40°F -40°C
<b>UHMW PE:</b> A thermoplastic that is highly resistant to a broad range of chemicals. Exhibits outstanding abrasion and impact resistance, along with environmental stress-cracking resistance.	180°F 82°C	-35°F -37°C
<b>Polyurethane:</b> Shows good resistance to abrasives. Has poor resistance to most solvents and oils.	150°F 66°C	32°F 0°C
<b>Virgin PTFE:</b> (PFA/TFE) Chemically inert, virtually impervious. Very few chemicals are known to chemically react with PTFE; molten alkali metals, turbulent liquid or gaseous fluorine and a few fluoro-chemicals such as chlorine trifluoride or oxygen difluoride which readily liberate free fluorine at elevated temperatures.	220°F 104°C	-35°F -37°C

Maximum and Minimum Temperatures are the limits for which these materials can be operated. Temperatures coupled with pressure affect the longevity of diaphragm pump components. Maximum life should not be expected at the extreme limits of the temperature ranges.

### Metals:

- Alloy C:** Equal to ASTM494 CW-12M-1 specification for nickel and nickel alloy.
- Stainless Steel:** Equal to or exceeding ASTM specification A743 CF-8M for corrosion resistant iron chromium, iron chromium nickel and nickel based alloy castings for general applications. Commonly referred to as 316 Stainless Steel in the pump industry.

For specific applications, always consult the Chemical Resistance Chart.



## S05 Metallic (Aluminum Model)

Dimensions in Inches. Dimensional tolerance:  $\pm 1/8"$

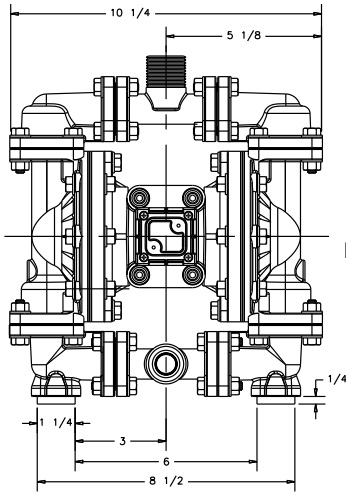

FRONT VIEW

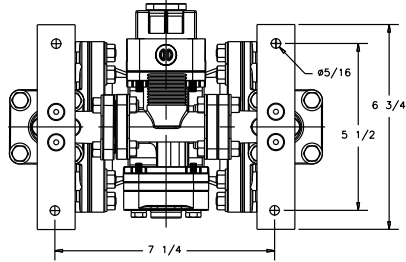

BOTTOM VIEW

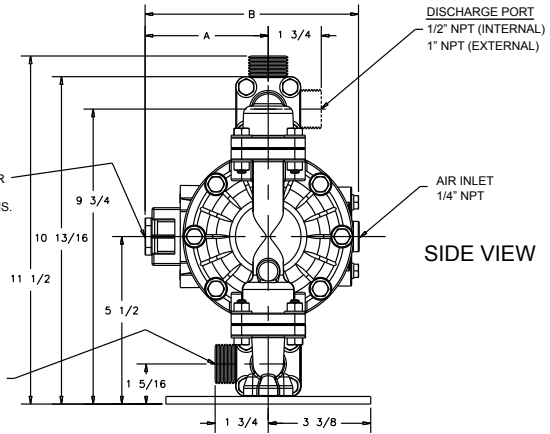

SIDE VIEW

BOTH SUCTION AND DISCHARGE PORTS ARE AVAILABLE IN 1/2" BSP TAPERED (INTERNAL) 1" BSP TAPERED (EXTERNAL)

DIMENSION	A	B
Integral Muffler	4 5/16"	7 5/16"
Pulse Output Kit	4 5/16"	7 5/16"
Mesh Muffler	6"	9"
Sound Dampening Muffler	6"	9"
Metal Muffler	5 5/8"	8 5/8"

## S05 Metallic (Aluminum Model)

Dimensions in millimeters. Dimensional tolerance:  $\pm 3\text{mm}$

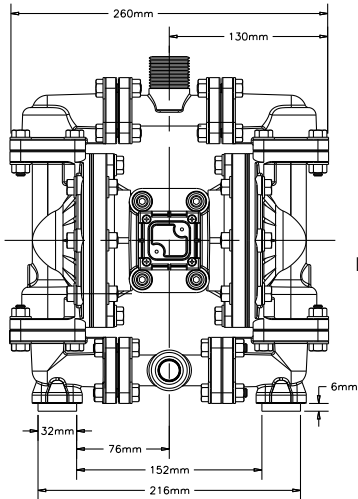

FRONT VIEW

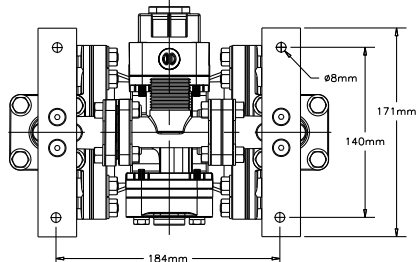

BOTTOM VIEW

ENCAPSULATED MUFFLER: 3/8" NPT EXHAUST PORT FOR OPTIONAL PIPING MUFFLER STYLES OR PIPING EXHAUST AIR IN SUBMERGED APPLICATIONS.

BOTH SUCTION AND DISCHARGE PORTS ARE AVAILABLE IN 1/2" BSP TAPERED (INTERNAL) 1" BSP TAPERED (EXTERNAL)

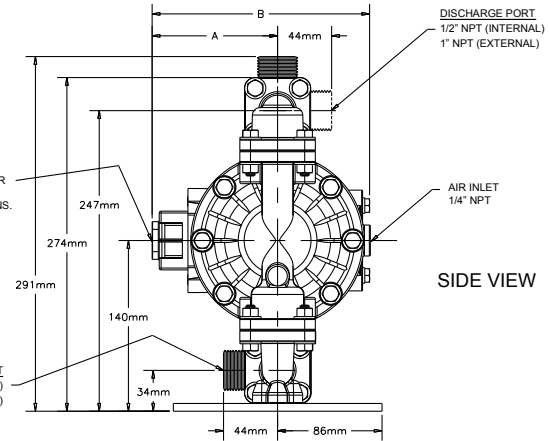

SIDE VIEW

DIMENSION	A	B
Integral Muffler	109 mm	186 mm
Pulse Output Kit	109 mm	186 mm
Mesh Muffler	152 mm	229 mm
Sound Dampening Muffler	152 mm	229 mm
Metal Muffler	143 mm	219 mm

# S05 Metallic - Stainless Steel NPT

Dimensions in inches (mm dimensions in brackets). Dimensional Tolerance:  $\pm 1/8"$  ( $\pm 3\text{mm}$ )  
 The dimensions on this drawing are for reference only. A certified drawing can be requested if physical dimensions are needed.

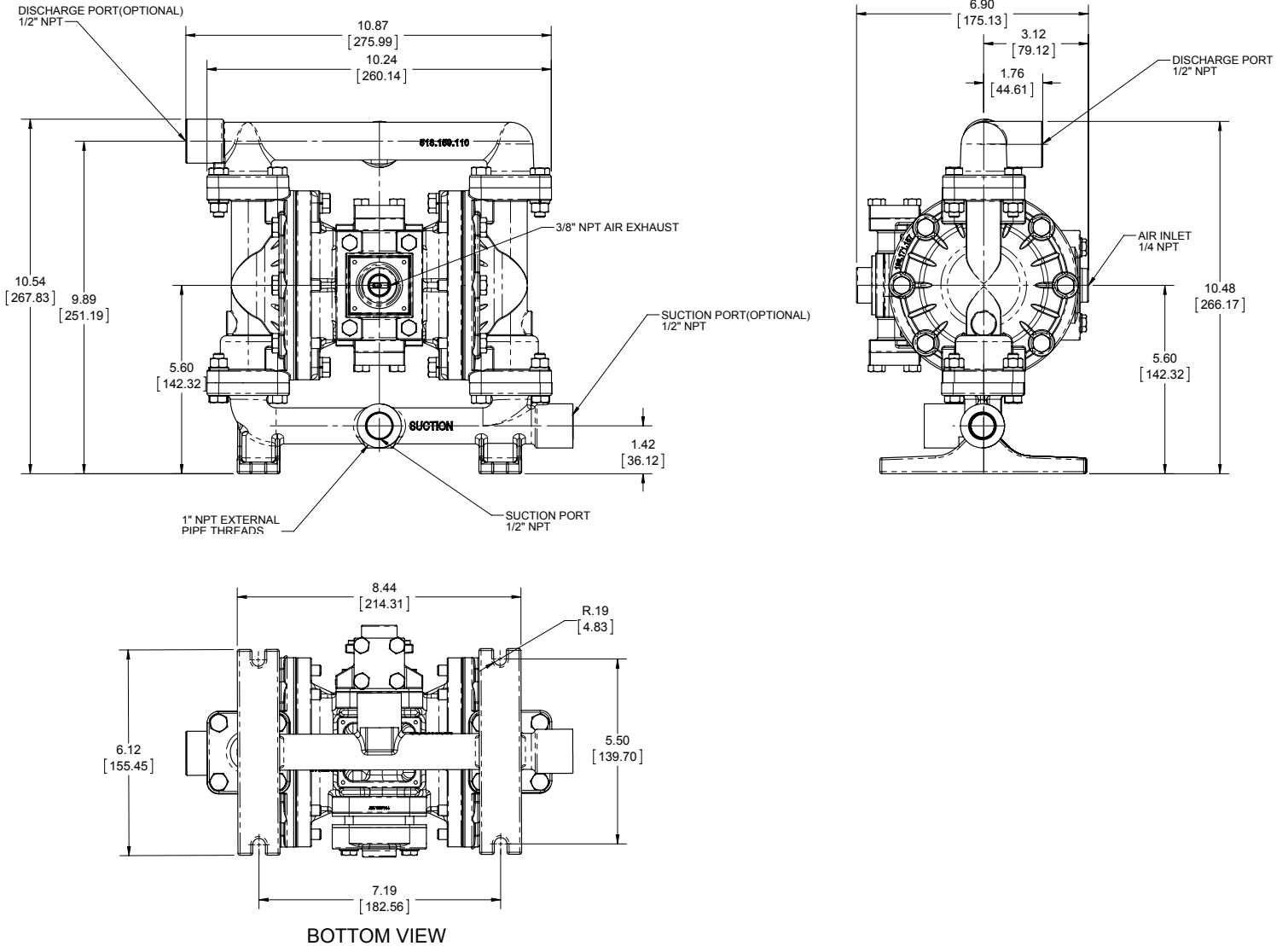

# Dimensional Drawings

## S05 Metallic - Stainless Steel ANSI Flange

Dimensions in inches (mm dimensions in brackets). Dimensional Tolerance:  $\pm 1/8"$  ( $\pm 3\text{mm}$ )

The dimensions on this drawing are for reference only. A certified drawing can be requested if physical dimensions are needed.

1: PUMP SPECS

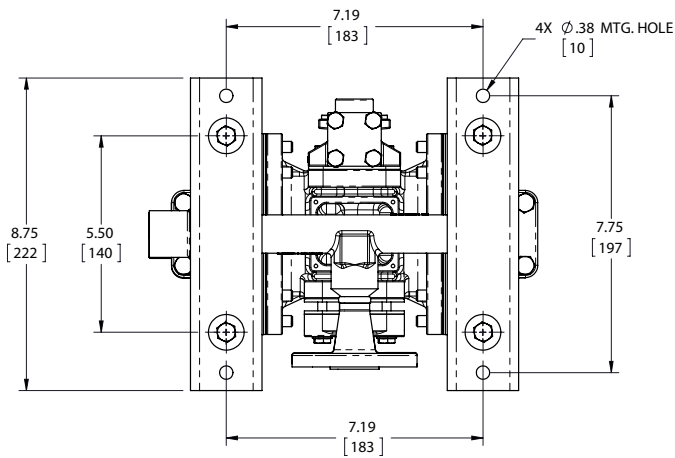
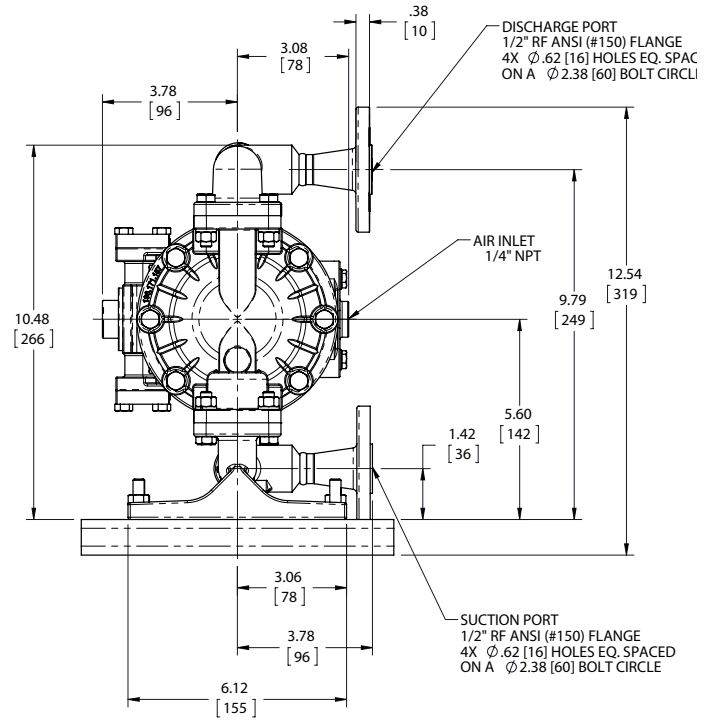
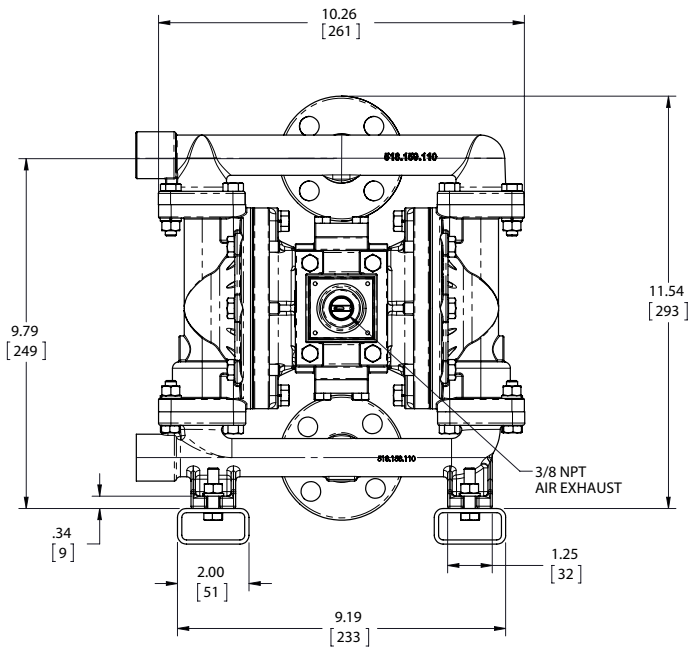



# Principle of Pump Operation

Air-Operated Double Diaphragm (AODD) pumps are powered by compressed air or nitrogen.

The main directional (air) control valve ① distributes compressed air to an air chamber, exerting uniform pressure over the inner surface of the diaphragm ②. At the same time, the exhausting air ③ from behind the opposite diaphragm is directed through the air valve assembly(s) to an exhaust port ④.

As inner chamber pressure (P1) exceeds liquid chamber pressure (P2), the rod ⑤ connected diaphragms shift together creating discharge on one side and suction on the opposite side. The discharged and primed liquid's directions are controlled by the check valves (ball or flap) ⑥ orientation.

The pump primes as a result of the suction stroke. The suction stroke lowers the chamber pressure (P3) increasing the chamber volume. This results in a pressure differential necessary for atmospheric pressure (P4) to push the fluid through the suction piping and across the suction side check valve and into the outer fluid chamber ⑦.

Suction (side) stroking also initiates the reciprocating (shifting, stroking or cycling) action of the pump. The suction diaphragm's movement is mechanically pulled through its stroke. The diaphragm's inner plate makes contact with an actuator plunger aligned to shift the pilot signaling valve. Once actuated, the pilot valve sends a pressure signal to the opposite end of the main directional air valve, redirecting the compressed air to the opposite inner chamber.

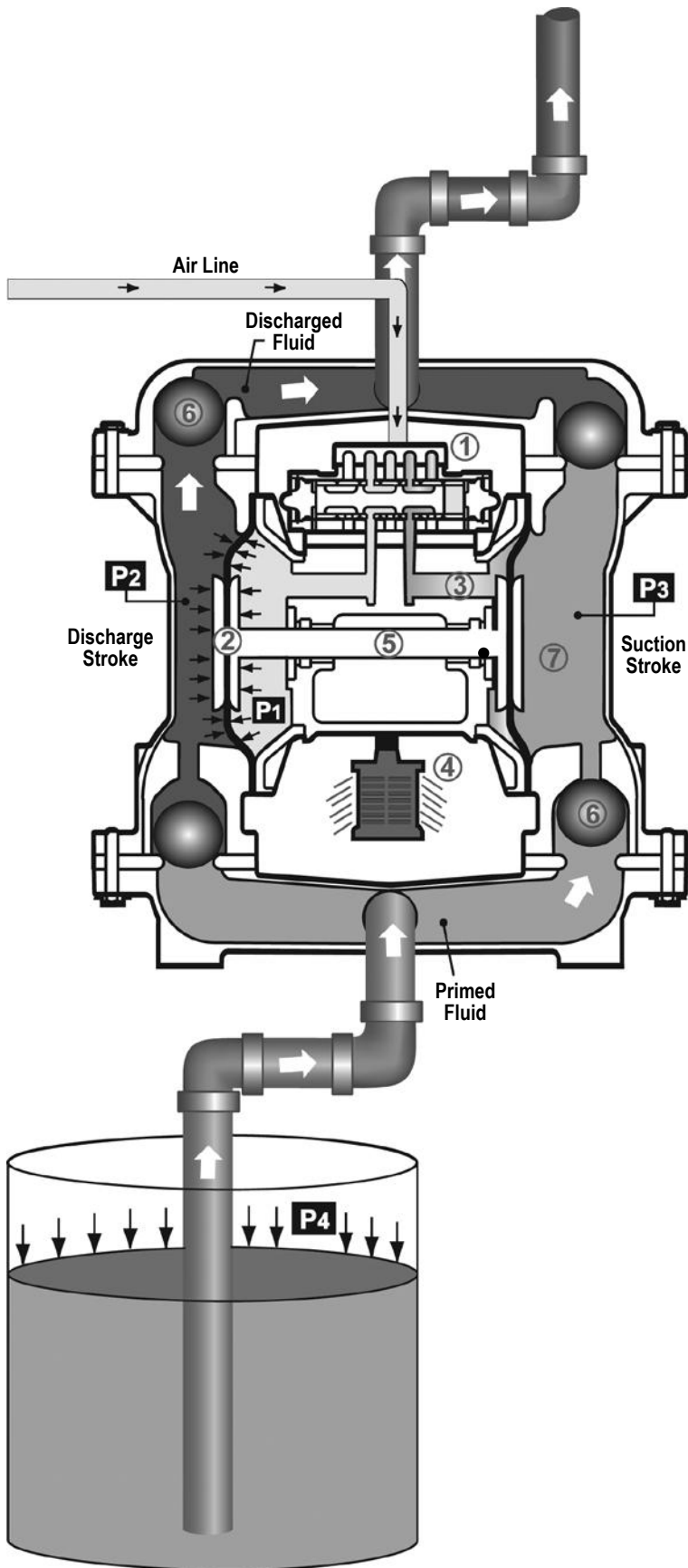

## SUBMERGED ILLUSTRATION

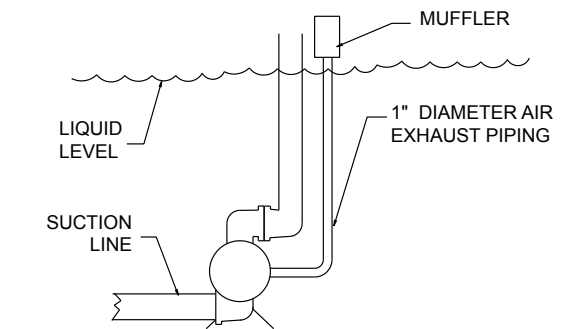

Pump can be submerged if the pump materials of construction are compatible with the liquid being pumped. The air exhaust must be piped above the liquid level. When the pumped product source is at a higher level than the pump (flooded suction condition), pipe the exhaust higher than the product source to prevent siphoning spills.

# Recommended Installation Guide

## Available Accessories:

1. Surge Suppressor
2. Filter/Regulator
3. Air Dryer

**Note:** Surge Suppressor and Piping must be supported after the flexible connection

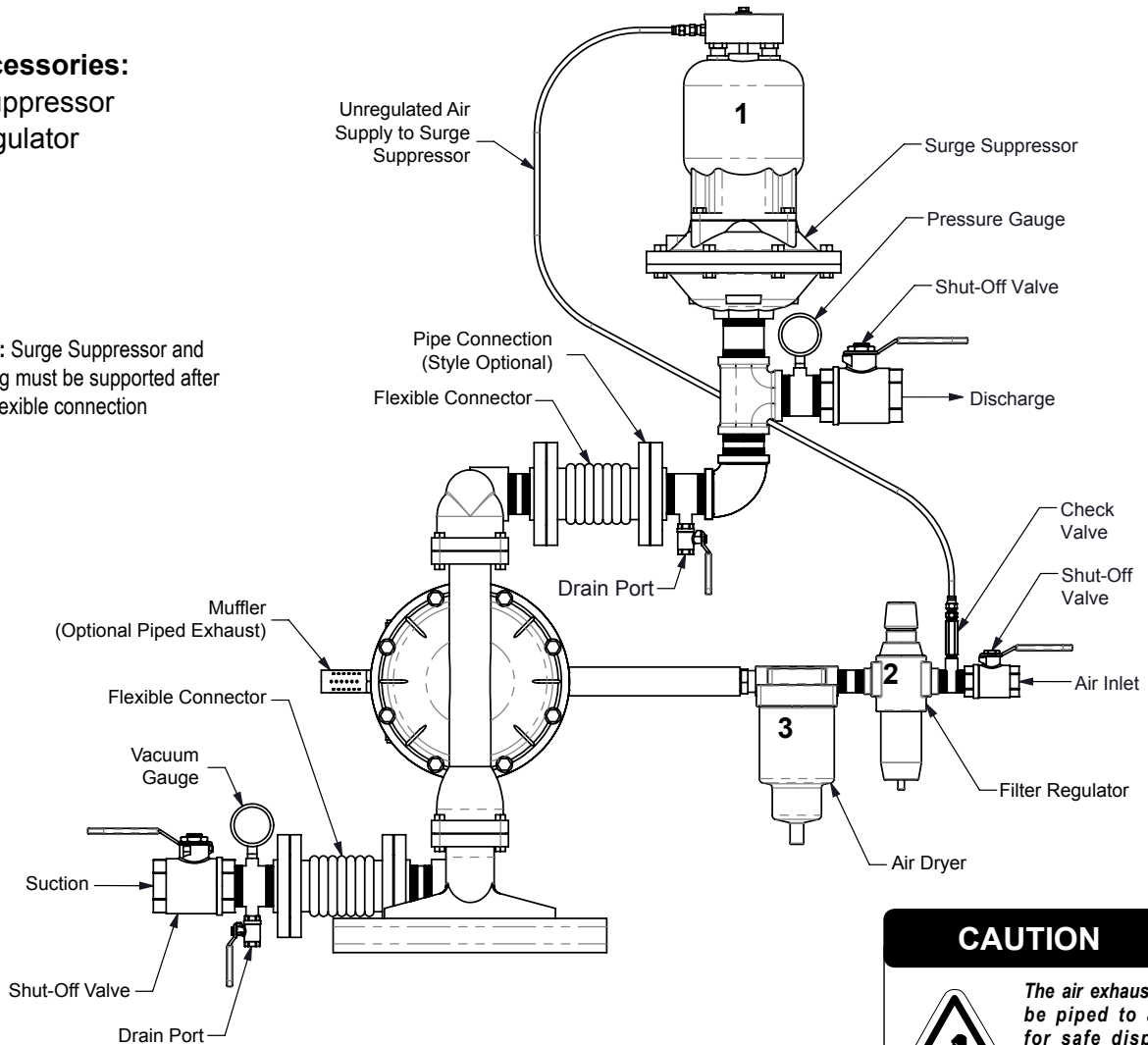

## CAUTION



*The air exhaust should be piped to an area for safe disposition of the product being pumped, in the event of a diaphragm failure.*

### Installation And Start-Up

Locate the pump as close to the product being pumped as possible. Keep the suction line length and number of fittings to a minimum. Do not reduce the suction line diameter.

### Air Supply

Connect the pump air inlet to an air supply with sufficient capacity and pressure to achieve desired performance. A pressure regulating valve should be installed to insure air supply pressure does not exceed recommended limits.

### Air Valve Lubrication

The air distribution system is designed to operate **WITHOUT** lubrication. This is the standard mode of operation. If lubrication is desired, install an air line lubricator set to deliver one drop of SAE 10 non-detergent oil for every 20 SCFM (9.4 liters/sec.) of air the pump consumes. Consult the Performance Curve to determine air consumption.

### Air Line Moisture

Water in the compressed air supply may cause icing or freezing of the exhaust air, causing the pump to cycle erratically or stop operating. Water in the air supply can be reduced by using a point-of-use air dryer.

### Air Inlet And Priming

To start the pump, slightly open the air shut-off valve. After the pump primes, the air valve can be opened to increase air flow as desired. If opening the valve increases cycling rate, but does not increase the rate of flow, cavitation has occurred. The valve should be closed slightly to obtain the most efficient air flow to pump flow ratio.

# Troubleshooting Guide

Symptom:	Potential Cause(s):	Recommendation(s):
<b>Pump Cycles Once</b>	Deadhead (system pressure meets or exceeds air supply pressure).	Increase the inlet air pressure to the pump. Pump is designed for 1:1 pressure ratio at zero flow. (Does not apply to high pressure 2:1 units).
	Air valve or intermediate gaskets installed incorrectly.	Install gaskets with holes properly aligned.
	Bent or missing actuator plunger.	Remove pilot valve and inspect actuator plungers.
<b>Pump Will Not Operate / Cycle</b>	Pump is over lubricated.	Set lubricator on lowest possible setting or remove. Units are designed for lube free operation.
	Lack of air (line size, PSI, CFM).	Check the air line size and length, compressor capacity (HP vs. CFM required).
	Check air distribution system.	Disassemble and inspect main air distribution valve, pilot valve and pilot valve actuators.
	Discharge line is blocked or clogged manifolds.	Check for inadvertently closed discharge line valves. Clean discharge manifolds/piping.
	Deadhead (system pressure meets or exceeds air supply pressure).	Increase the inlet air pressure to the pump. Pump is designed for 1:1 pressure ratio at zero flow. (Does not apply to high pressure 2:1 units).
	Blocked air exhaust muffler.	Remove muffler screen, clean or de-ice, and re-install.
	Pumped fluid in air exhaust muffler.	Disassemble pump chambers. Inspect for diaphragm rupture or loose diaphragm plate assembly.
	Pump chamber is blocked.	Disassemble and inspect wetted chambers. Remove or flush any obstructions.
<b>Pump Cycles and Will Not Prime or No Flow</b>	Cavitation on suction side.	Check suction condition (move pump closer to product).
	Check valve obstructed. Valve ball(s) not seating properly or sticking.	Disassemble the wet end of the pump and manually dislodge obstruction in the check valve pocket. Clean out around valve ball cage and valve seat area. Replace valve ball or valve seat if damaged. Use heavier valve ball material.
	Valve ball(s) missing (pushed into chamber or manifold).	Worn valve ball or valve seat. Worn fingers in valve ball cage (replace part). Check Chemical Resistance Guide for compatibility.
	Valve ball(s) / seat(s) damaged or attacked by product.	Check Chemical Resistance Guide for compatibility.
	Check valve and/or seat is worn or needs adjusting.	Inspect check valves and seats for wear and proper setting. Replace if necessary.
	Suction line is blocked.	Remove or flush obstruction. Check and clear all suction screens or strainers.
	Excessive suction lift.	For lifts exceeding 20' of liquid, filling the chambers with liquid will prime the pump in most cases.
	Suction side air leakage or air in product.	Visually inspect all suction-side gaskets and pipe connections.
	Pumped fluid in air exhaust muffler.	Disassemble pump chambers. Inspect for diaphragm rupture or loose diaphragm plate assembly.
<b>Pump Cycles Running Sluggish / Stalling, Flow Unsatisfactory</b>	Over lubrication.	Set lubricator on lowest possible setting or remove. Units are designed for lube free operation.
	Icing.	Remove muffler screen, de-ice, and re-install. Install a point of use air drier.
	Clogged manifolds.	Clean manifolds to allow proper air flow.
	Deadhead (system pressure meets or exceeds air supply pressure).	Increase the inlet air pressure to the pump. Pump is designed for 1:1 pressure ratio at zero flow. (Does not apply to high pressure 2:1 units).
	Cavitation on suction side.	Check suction (move pump closer to product).
	Lack of air (line size, PSI, CFM).	Check the air line size, length, compressor capacity.
	Excessive suction lift.	For lifts exceeding 20' of liquid, filling the chambers with liquid will prime the pump in most cases.
	Air supply pressure or volume exceeds system hd.	Decrease inlet air (press. and vol.) to the pump. Pump is cavitating the fluid by fast cycling.
	Undersized suction line.	Meet or exceed pump connections.
	Restrictive or undersized air line.	Install a larger air line and connection.
	Suction side air leakage or air in product.	Visually inspect all suction-side gaskets and pipe connections.
	Suction line is blocked.	Remove or flush obstruction. Check and clear all suction screens or strainers.
	Pumped fluid in air exhaust muffler.	Disassemble pump chambers. Inspect for diaphragm rupture or loose diaphragm plate assembly.
	Check valve obstructed.	Disassemble the wet end of the pump and manually dislodge obstruction in the check valve pocket.
	Check valve and/or seat is worn or needs adjusting.	Inspect check valves and seats for wear and proper setting. Replace if necessary.
Entrained air or vapor lock in chamber(s).	Purge chambers through tapped chamber vent plugs. Purging the chambers of air can be dangerous.	
<b>Product Leaking Through Exhaust</b>	Diaphragm failure, or diaphragm plates loose.	Replace diaphragms, check for damage and ensure diaphragm plates are tight.
	Diaphragm stretched around center hole or bolt holes.	Check for excessive inlet pressure or air pressure. Consult Chemical Resistance Chart for compatibility with products, cleaners, temperature limitations and lubrication.
<b>Premature Diaphragm Failure</b>	Cavitation.	Enlarge pipe diameter on suction side of pump.
	Excessive flooded suction pressure.	Move pump closer to product. Raise pump/place pump on top of tank to reduce inlet pressure. Install Back pressure device (Tech bulletin 41r). Add accumulation tank or pulsation dampener.
	Misapplication (chemical/physical incompatibility).	Consult Chemical Resistance Chart for compatibility with products, cleaners, temperature limitations and lubrication.
	Incorrect diaphragm plates or plates on backwards, installed incorrectly or worn.	Check Operating Manual to check for correct part and installation. Ensure outer plates have not been worn to a sharp edge.
<b>Unbalanced Cycling</b>	Excessive suction lift.	For lifts exceeding 20' of liquid, filling the chambers with liquid will prime the pump in most cases.
	Undersized suction line.	Meet or exceed pump connections.
	Pumped fluid in air exhaust muffler.	Disassemble pump chambers. Inspect for diaphragm rupture or loose diaphragm plate assembly.
	Suction side air leakage or air in product.	Visually inspect all suction-side gaskets and pipe connections.
	Check valve obstructed.	Disassemble the wet end of the pump and manually dislodge obstruction in the check valve pocket.
	Check valve and/or seat is worn or needs adjusting.	Inspect check valves and seats for wear and proper setting. Replace if necessary.
Entrained air or vapor lock in chamber(s).	Purge chambers through tapped chamber vent plugs.	

For additional troubleshooting tips contact After Sales Support at [service.warrenrupp@idexcorp.com](mailto:service.warrenrupp@idexcorp.com) or 419-524-8388

# Composite Repair Parts Drawing

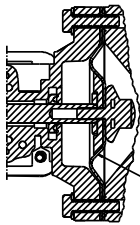
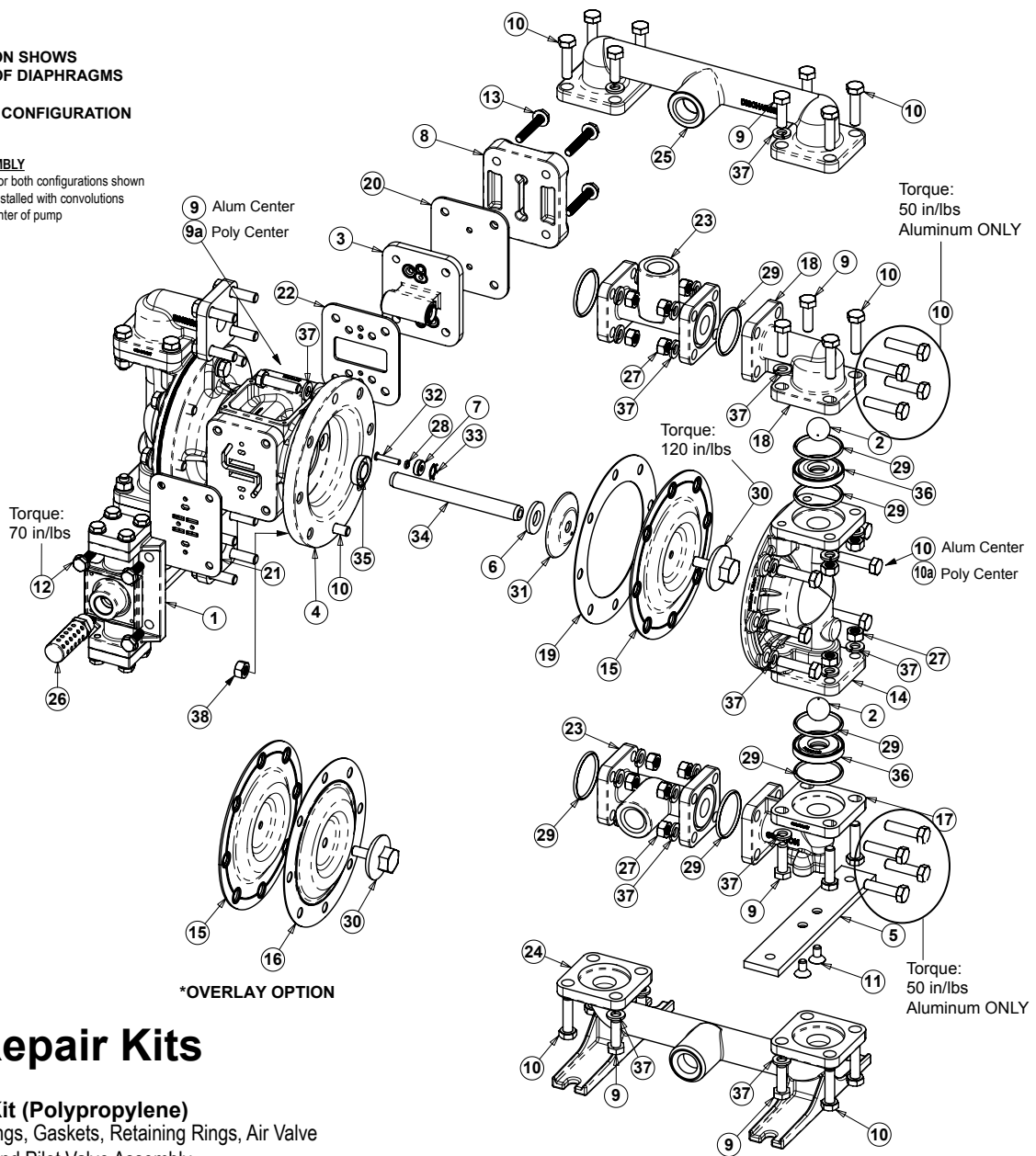

ILLUSTRATION SHOWS  
DIRECTION OF DIAPHRAGMS

DIAPHRAGM CONFIGURATION  
DETAIL

**NOTE TO ASSEMBLY**

The diaphragms for both configurations shown above are to be installed with convolutions facing towards center of pump



## Service & Repair Kits

- 476-219-000 Air End Kit (Polypropylene)**  
Seals, O-Rings, Gaskets, Retaining Rings, Air Valve Assembly and Pilot Valve Assembly.
- 476-239-000 Air End Kit**  
Seals, O-Rings, Gaskets, Bumpers, Retainers, Air Valve Assembly and Pilot Valve Assembly.
- 476-240-000 Air End Kit** for pumps equipped with Stroke Indicator (same components as above, except Air Valve Assembly with pins replaces Air Valve Standard).
- 476-199-354 Wetted End Kit**  
Santoprene Diaphragm, Santoprene Check Balls, UHMW Seats, Nitrile Spacer Gasket.
- 476-199-356 Wetted End Kit**  
Hytrel Diaphragm, Hytrel Check Balls, UHMW Seats.
- 476-199-360 Wetted End Kit**  
Nitrile Diaphragm, Nitrile Check Balls, UHMW Seats.
- 476-199-357 Wetted End Kit**  
Polyurethane Diaphragms  
Polyurethane Check Balls,  
UHMW Check Valve Seats  
Nitrile Spacer Gaskets

- 476-199-661 Wetted End Kit**  
EPDM Diaphragm, Santoprene Check Balls, UHMW Seats.
- 476-199-365 Wetted End Kit**  
Neoprene Diaphragm, Neoprene Check Balls, UHMW Seats.
- 476-199-633 Wetted End Kit**  
FKM Diaphragm, PTFE Check Balls, PTFE Seats.
- 476-199-650 Wetted End Kit**  
PTFE and Santoprene Diaphragm, PTFE Check Balls, PTFE Seats.
- 476-199-654 Wetted End Kit**  
Santoprene Diaphragm, PTFE Overlay Diaphragm, PTFE Check Balls, PTFE Seats.
- 476-199-659 Wetted End Kit**  
One-Piece Bonded PTFE/Nitrile Diaphragm, PTFE Balls, PTFE Seats.

3: EXP VIEW



# Composite Repair Parts List

Item	Part Number	Description	Qty	Item	Part Number	Description	Qty	
①	031.191.000	Air Valve Assembly (Integral Muffler)	1	20	360.100.379	Gasket, Air Inlet	1	
	031.166.000	Air Valve Assembly (Polypropylene Center w/Integral Muffler)	1	21	360.102.360	Gasket, Air Valve	1	
	031.168.000	Air Valve Assembly (Polypropylene Center w/External Muffler Options)	1	22	360.108.360	Gasket, Pilot Valve	1	
	▲ 031.168.002	Air Valve Assembly (Conductive Polypropylene Center ONLY)	1		360.101.360	Gasket, Pilot Valve (Polypropylene Centers ONLY)	1	
	031.167.000	Air Valve Assembly (w/stroke Indicator Pins)	1	23	518.157.157	Manifold (see item 29)	2	
	▲ 031.186.000	Air Valve Assembly	1		518.157.157E	Manifold BSP Tapered (see item 29)	2	
	▲ 031.169.000	Air Valve Assembly (Stroke Indicator & Optional Mufflers)	1	24	518.158.110	Manifold, Suction	1	
	▲ 031.186.003	Air Valve Assembly w/Stainless Steel hardware	1		518.158.110E	Manifold, Suction BSP Tapered	1	
	▲ 031.186.002	Air Valve (High Temperature)	1		518.158.110W	Welded Raised Face 150# 1/2" ANSI Flanged Manifold	1	
	▲ 031.191.002	Air Valve (High Temperature With Integral Mufflers)	1		518.158.112	Manifold, Suction	1	
		031.191.003	Air Valve Assembly (Stainless Steel Hardware)	1	25	518.158.112E	Manifold, Suction BSP Tapered	1
	②	050.022.600	Ball, Check	4		518.159.110	Manifold, Discharge	1
050.027.354		Ball, Check	4		518.159.110E	Manifold, Discharge BSP Tapered	1	
050.027.356		Ball, Check	4		518.159.110W	Welded Raised Face 150# 1/2" ANSI Flanged Manifold	1	
050.027.357		Ball, Check	4		518.159.112	Manifold, Discharge	1	
050.027.360		Ball, Check	4	26	530.035.000	Manifold, Discharge BSP Tapered	1	
050.027.364		Ball, Check	4	27	545.004.115	Metal Muffler	1	
050.027.365		Ball, Check	4		545.004.330	Nut, Hex 5/16-18 (Aluminum)	24	
095.091.000		Pilot Valve Assembly (Polypropylene Center ONLY)	1		545.004.330	Nut, Hex 5/16-18 (Stainless Steel)	8	
③	▲ 095.091.001	Pilot Valve Assembly (Conductive Polypropylene Center ONLY)	1	28	560.001.360	Nut, Hex 5/16-18 (Stainless Steel)	8	
	▲ 095.116.000	Pilot Valve Assembly	1	29	560.003.360	O-Ring	2	
4	▲ 114.023.157	Bracket, Intermediate	1		560.083.363	O-Ring (Aluminum Manifold)	4	
	114.023.551	Bracket, Intermediate (Polypropylene Center ONLY)	1		560.083.364	O-Ring (Aluminum Manifold)	4	
	▲ 114.023.559	Bracket, Intermediate (Conductive Polypropylene Center ONLY)	1		560.083.365	O-Ring (Aluminum Manifold)	4	
5	115.152.151	Bracket, Mounting (Aluminum)	2		720.064.600	O-Ring (Aluminum Manifold)	4	
⑥	132.034.360	Bumper, Diaphragm	2		560.083.360	Seal (Aluminum Manifold)	4	
⑦	135.036.506	Bushing, Plunger	2		560.083.363	O-Ring (metallic seats only)	8	
8	▲ 165.110.157	Cap, Air Inlet	1		560.083.364	O-Ring (metallic seats only)	8	
	▲ 165.110.551	Cap, Air Inlet (Polypropylene Center ONLY)	1		560.083.365	O-Ring (metallic seats only)	8	
9	▲ 165.110.559	Cap, Air Inlet (Polypropylene Center ONLY)	1	30	560.083.611	O-Ring (metallic seats only)	8	
	170.044.115	Capscrew, Hex 5/16-18 X 1.00	12		612.091.110	O-Ring (metallic seats only)	8	
9A	170.044.115	Capscrew, Hex 5/16-18 X 1.00 (Polypropylene Center ONLY)	8		612.091.112	Plate, Outer Diaphragm	2	
	170.044.330	Capscrew, Hex 5/16-18 X 1.00	12	31	612.091.157	Plate, Outer Diaphragm	2	
10	170.045.115	Capscrew, Hex 5/16-18 X 1.25 (Alum)	40		612.177.330	Plate, Inner Diaphragm	2	
	170.045.330	Capscrew, Hex 5/16-18 X 1.25 (Alum)	40		612.221.330	Plate, Inner Diaphragm (One-Piece Bonded Only)	2	
	170.045.115	Capscrew, Hex 5/16-18 x 1.25 (SS)	24	32	620.019.115	Plunger, Actuator	2	
	170.045.330	Capscrew, Hex 5/16-18 x 1.25 (SS)	24	33	675.042.115	Ring, Retainer	2	
	170.045.115	Capscrew, Hex 5/16-18 x 1.25 (Polypropylene Centers ONLY)	8	34	685.056.120	Rod, Diaphragm	1	
	170.045.115	Capscrew, Hex 5/16-18 x 1.25 (Polypropylene Centers ONLY)	4	35	720.012.360	Seal, U-Cup Shaft	2	
10A	170.029.115	Capscrew, Hex 5/16-18 x 1.50 (Polypropylene Centers ONLY)	12	36	722.094.080	Seat, Check Valve (item 29 required)	4	
	171.017.115	Capscrew, Flat Socket Head 1/4.20 x .50 (Alum)	4		722.094.110	Seat, Check Valve (item 29 required)	4	
	171.017.330	Capscrew, Flat Socket Head 1/4.20 x .50 (Alum)	4		722.094.150	Seat, Check Valve (item 29 required)	4	
	171.076.115	Capscrew, Flanged 1/4-20 x 75	4		722.094.550	Seat, Check Valve	4	
12	171.076.330	Capscrew, Flanged 1/4-20 x 75	4		722.094.600	Seat, Check Valve	4	
	171.066.115	Capscrew, Flanged 1/4-20 x 1.25 (Polypropylene Centers ONLY)	4	37	900.004.115	5/16 Lock Washer (Aluminum)	48	
13	171.077.115	Capscrew, Flanged 1/4-20 x 1.50	4		900.004.330	5/16 Lock Washer (Aluminum)	48	
	171.077.330	Capscrew, Flanged 1/4-20 x 1.50	4		900.004.115	5/16 Lock Washer (Stainless Steel)	32	
	171.066.115	Capscrew, Flanged 1/4-20 x 1.25 (Polypropylene Centers ONLY)	4		900.004.330	5/16 Lock Washer (Stainless Steel)	32	
14	196.171.110	Chamber, Outer	2	38	544.005.115	5/16 Lock Washer (Stainless Steel)(Poly Center ONLY)	28	
	196.171.112	Chamber, Outer	2			Nut, Flanged 5/16-18 (Poly Centers ONLY)	12	
	196.171.157	Chamber, Outer	2					
⑮	286.095.354	Diaphragm	2					
	286.095.356	Diaphragm	2					
	286.095.357	Diaphragm	2					
	286.095.360	Diaphragm	2					
	286.095.363	Diaphragm	2					
	286.095.364	Diaphragm	2					
	286.095.365	Diaphragm	2					
	286.116.000	Diaphragm, One.Piece Bonded	2					
	286.096.600	Diaphragm, Overlay	2					
	312.110.157	Elbow, Suction	2					
312.111.157	Elbow, Discharge	2						
⑰	360.099.360	Gasket, Spacer (Use TPE Diaphragms only)	2					

3: EXP VIEW

Parts not shown used with Raised Face ANSI Flange Options R and W:

170.043.330	Hex Cap Screw	4
326.054.080	Mounting Foot	2
545.003.330	Hex Nut	4
900.001.330	Lock Washer	4
901.035.330	Flat Washer	8

Parts not shown used with Raised Face ANSI Flange Option R ONLY:

334.110.110	1/2" ANSI 150# Raised Face Flange and Threaded Pipe Connection	
538.006.110	1/2" NPT Pipe Nipple x 1-1/2 Long	

**LEGEND:**  
 ○ = Items contained within Air End Kits  
 □ = Items contained within Wet End Kits

**Note:** Kits contain components specific to the material codes.



**NOTE:** See Pages 11 and 12 For Full Explanation of Air Valve Options.

# Material Codes - The Last 3 Digits of Part Number

000.....Assembly, sub-assembly;  
and some purchased items

010.....Cast Iron

015.....Ductile Iron

020.....Ferritic Malleable Iron

080.....Carbon Steel, AISI B-1112

110.....Alloy Type 316 Stainless Steel

111.....Alloy Type 316 Stainless Steel  
(Electro Polished)

112.....Alloy C

113.....Alloy Type 316 Stainless Steel  
(Hand Polished)

114.....303 Stainless Steel

115.....302/304 Stainless Steel

117.....440-C Stainless Steel (Martensitic)

120.....416 Stainless Steel  
(Wrought Martensitic)

148.....Hardcoat Anodized Aluminum

150.....6061-T6 Aluminum

152.....2024-T4 Aluminum (2023-T351)

155.....356-T6 Aluminum

156.....356-T6 Aluminum

157.....Die Cast Aluminum Alloy #380

158.....Aluminum Alloy SR-319

162.....Brass, Yellow, Screw Machine Stock

165.....Cast Bronze, 85-5-5-5

166.....Bronze, SAE 660

170.....Bronze, Bearing Type,  
Oil Impregnated

180.....Copper Alloy

305.....Carbon Steel, Black Epoxy Coated

306.....Carbon Steel, Black PTFE Coated

307.....Aluminum, Black Epoxy Coated

308.....Stainless Steel, Black PTFE Coated

309.....Aluminum, Black PTFE Coated

313.....Aluminum, White Epoxy Coated

330.....Zinc Plated Steel

332.....Aluminum, Electroless Nickel Plated

333.....Carbon Steel, Electroless  
Nickel Plated

335.....Galvanized Steel

337.....Silver Plated Steel

351.....Food Grade Santoprene®

353.....Geolast; Color: Black

354.....Injection Molded #203-40  
Santoprene® Duro 40D +/-5;  
Color: RED

356.....Hytrel®

357.....Injection Molded Polyurethane

358.....Urethane Rubber  
(Some Applications)  
(Compression Mold)

359.....Urethane Rubber

360.....Nitrile Rubber Color coded: RED

363.....FKM (Fluorocarbon)  
Color coded: YELLOW

364.....EPDM Rubber  
Color coded: BLUE

365.....Neoprene Rubber  
Color coded: GREEN

366.....Food Grade Nitrile

368.....Food Grade EPDM

371.....Philthane (Tuftane)

374.....Carboxylated Nitrile

375.....Fluorinated Nitrile

378.....High Density Polypropylene

379.....Conductive Nitrile

408.....Cork and Neoprene

425.....Compressed Fibre

426.....Blue Gard

440.....Vegetable Fibre

500.....Delrin® 500

502.....Conductive Acetal, ESD-800

503.....Conductive Acetal, Glass-Filled

506.....Delrin® 150

520.....Injection Molded PVDF  
Natural color

540.....Nylon

542.....Nylon

544.....Nylon Injection Molded

550.....Polyethylene

551.....Glass Filled Polypropylene

552.....Unfilled Polypropylene

555.....Polyvinyl Chloride

556.....Black Vinyl

557.....Unfilled Conductive Polypropylene

558.....Conductive HDPE

559.....Glass Filled - Conductive Polypropylene

570.....Rulon II®

580.....Ryton®

600.....PTFE (virgin material)  
Tetrafluorocarbon (TFE)

603.....Blue Gylon®

604.....PTFE

606.....PTFE

607.....Envelon

608.....Conductive PTFE

610.....PTFE Encapsulated Silicon

611.....PTFE Encapsulated FKM

632.....Neoprene/Hytrel®

633.....FKM/PTFE

634.....EPDM/PTFE

635.....Neoprene/PTFE

637.....PTFE, FKM/PTFE

638.....PTFE, Hytrel®/PTFE

639.....Nitrile/TFE

643.....Santoprene®/EPDM

644.....Santoprene®/PTFE

656.....Santoprene® Diaphragm and  
Check Balls/EPDM Seats

661.....EPDM/Santoprene®

666.....FDA Nitrile Diaphragm,  
PTFE Overlay, Balls, and Seals

668.....PTFE, FDA Santoprene®/PTFE

- Delrin and Hytrel are registered tradenames of E.I. DuPont.
- Nylatron is a registered tradename of Polymer Corp.
- Gylon is a registered tradename of Garlock, Inc.
- Santoprene is a registered tradename of Exxon Mobil Corp.
- Rulon II is a registered tradename of Dixon Industries Corp.
- Ryton is a registered tradename of Phillips Chemical Co.
- Valox is a registered tradename of General Electric Co.

## RECYCLING

Many components of SANDPIPER® AODD pumps are made of recyclable materials. We encourage pump users to recycle worn out parts and pumps whenever possible, after any hazardous pumped fluids are thoroughly flushed.



# Air Distribution Valve Assembly

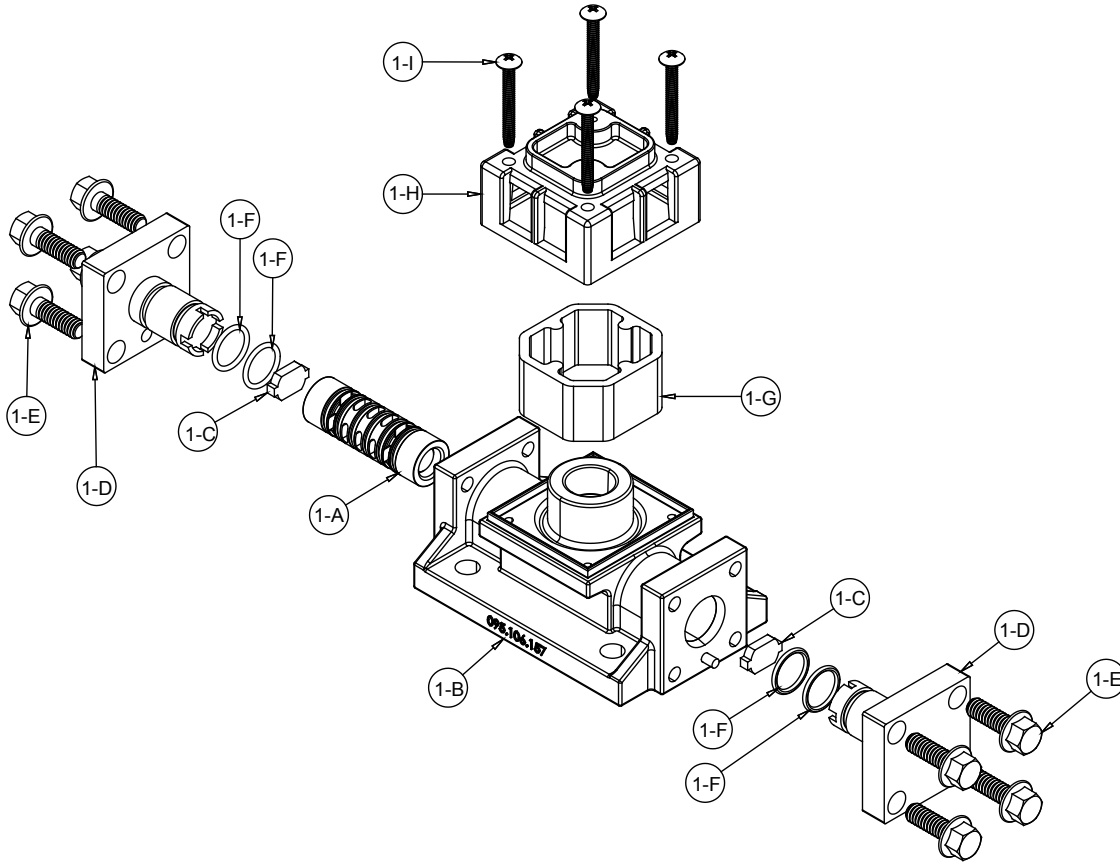

## Air Distribution Valve Servicing

See repair parts drawing, remove screws.

**Step 1:** Remove hex capscrews (1-E).

**Step 2:** Remove end cap (1-D).

**Step 3:** Remove spool part of (1-A) (caution: do not scratch).

**Step 4:** Press sleeve (1-A) from body (1-B).

**Step 5:** Inspect bumpers (1-C) and o-rings (1-F).

**Step 6:** Lightly lubricate O-Rings (1-F) on sleeve (1-A).

**Step 7:** Press sleeve (1-A) into body (1-B).

**Step 8:** Reassemble in reverse order, starting with step 3.

**Note:** Sleeve and spool (1-A) set is match ground to a specified clearance sleeve and spools (1-A) cannot be interchanged.

**⚠ IMPORTANT**

 *Read these instructions completely, before installation and start-up. It is the responsibility of the purchaser to retain this manual for reference. Failure to comply with the recommendations stated in this manual will damage the pump, and void factory warranty.*

 **⚠ ATEX Compliant**

**⚠ Note:** Pumps equipped with this valve assembly are ATEX compliant when a metal muffer is used.

### Main Air Valve Assembly Parts List

Item	Part Number	Description	Qty
1	031.191.000	Valve Assembly	1
1-A	031.132.000	Sleeve and Spool Set	1
1-B	095.106.157	Valve Body	1
1-C	132.038.357	Bumper	2
1-D	165.128.157	End Cap	2
1-E	171.076.330	Hex Flange Capscrew 1/4-20 x .75	8
1-F	560.101.360	O.Ring	4
1-G	530.031.550	Muffer	1
1-H	165.109.551	Muffer Cap	1
1-I	706.027.330	Machine Screw	4

Item	Part number	Description	QTY
1	031.191.003	Valve Assembly	1
		(same as above 031.191.003 except items 1-E, and 1-I)	
1-E	171.076.115	Hex Flange Capscrew 1/4-20 x .75	8
1-I	706.027.115	Machine Screw	4

### Main Air Valve Assembly Parts List

Item	Part Number	Description	Qty
<b>⚠</b> 1	031.186.000	Valve Assembly	1
		(Same as above 031.191.000 minus items 1-G, 1-H, and 1-I)	
<b>⚠</b> Item	Part Number	Description	Qty
<b>⚠</b> 1	031.186.003	Valve Assembly	1
		(Same as above 031.186.003 except item 1-E)	
1-E	171.076.115	Hex Flange Capscrew 1/4-20 x .75	8

# Air Distribution Valve Assembly for Polypropylene Center Sections

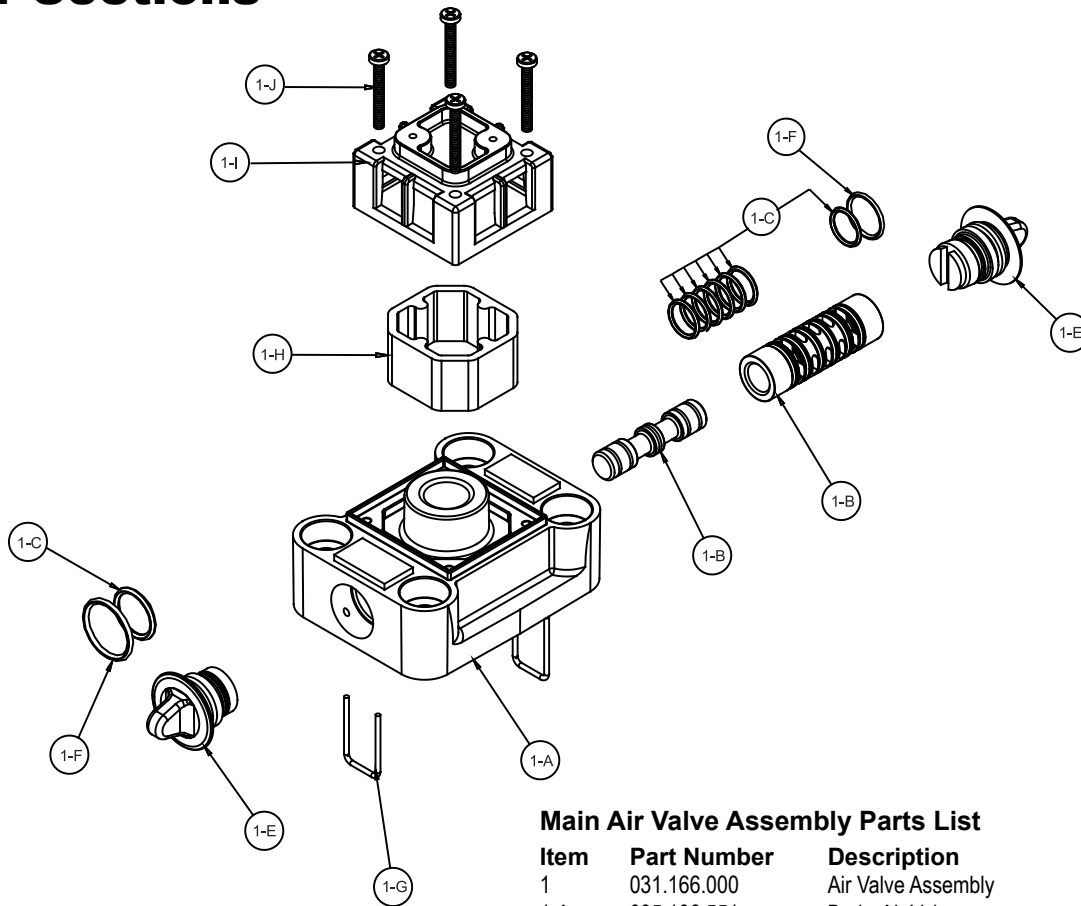

## Main Air Valve Assembly Parts List

Item	Part Number	Description	Qty
1	031.166.000	Air Valve Assembly	1
1-A	095.106.551	Body, Air Valve	1
1-B	031.132.000	Sleeve and Spool Set	1
1-C	560.101.360	O-Ring	8
1-E	165.122.551	End Cap	2
1-F	560.026.360	O-Ring	2
1-G	675.062.115	End Cap Retainer	2
1-H	530.031.550	Muffler	1
1-I	165.109.551	Muffler Cap	1
1-J	710.011.115	Self-Tapping Screw	4

### For Pumps with Virgin PTFE coated hardware:

1	031.166.002	Air Valve Assembly	1
1-G	675.062.308	End Cap Retainer	2
1-J	710.011.308	Self Tapping Screw	4

(Includes all other items used on 031.166.000 above)

### For Pumps with alternate Mesh or Sound Dampening Mufflers or Piped Exhaust:

1	031.168.000	Air Valve Assembly	1
---	-------------	--------------------	---

(Includes all items used on 031.166.000 above minus 1-H, 1-I and 1-J)

## Main Air Valve Assembly Parts List (For conductive polypropylene center only)

Item	Part Number	Description	Qty
1	031.168.002	Air Valve Assembly	1
1-A	095.106.559	Body, Air Valve	1
1-B	031.132.000	Sleeve and Spool Set	1
1-C	560.101.360	O-Ring	8
1-E	165.122.558	End Cap	2
1-F	560.026.360	O-Ring	2
1-G	675.062.115	End Cap Retainer	2

## Air Distribution Valve Servicing

See repair parts drawing, remove screws.

**Step 1:** Remove end cap retainer (1-G).

**Step 2:** Remove end cap (1-E).

**Step 3:** Remove spool part of (1-B) (caution: do not scratch).

**Step 4:** Press sleeve (1-B) from body (1-A).

**Step 5:** Inspect O-Rings (1-C) and replace if necessary.

**Step 6:** Lightly lubricate O-Rings (1-C) on sleeve (1-B).

**Step 7:** Press sleeve (1-B) into body (1-A).

**Step 8:** Reassemble in reverse order, starting with step 3.

**Note:** Sleeve and spool (1-B) set is match ground to a specified clearance sleeve and spools (1-B) cannot be interchanged.

### IMPORTANT



Read these instructions completely, before installation and start-up. It is the responsibility of the purchaser to retain this manual for reference. Failure to comply with the recommendations stated in this manual will damage the pump, and void factory warranty.



**ATEX Compliant**

# Air Valve with Stroke Indicator Assembly

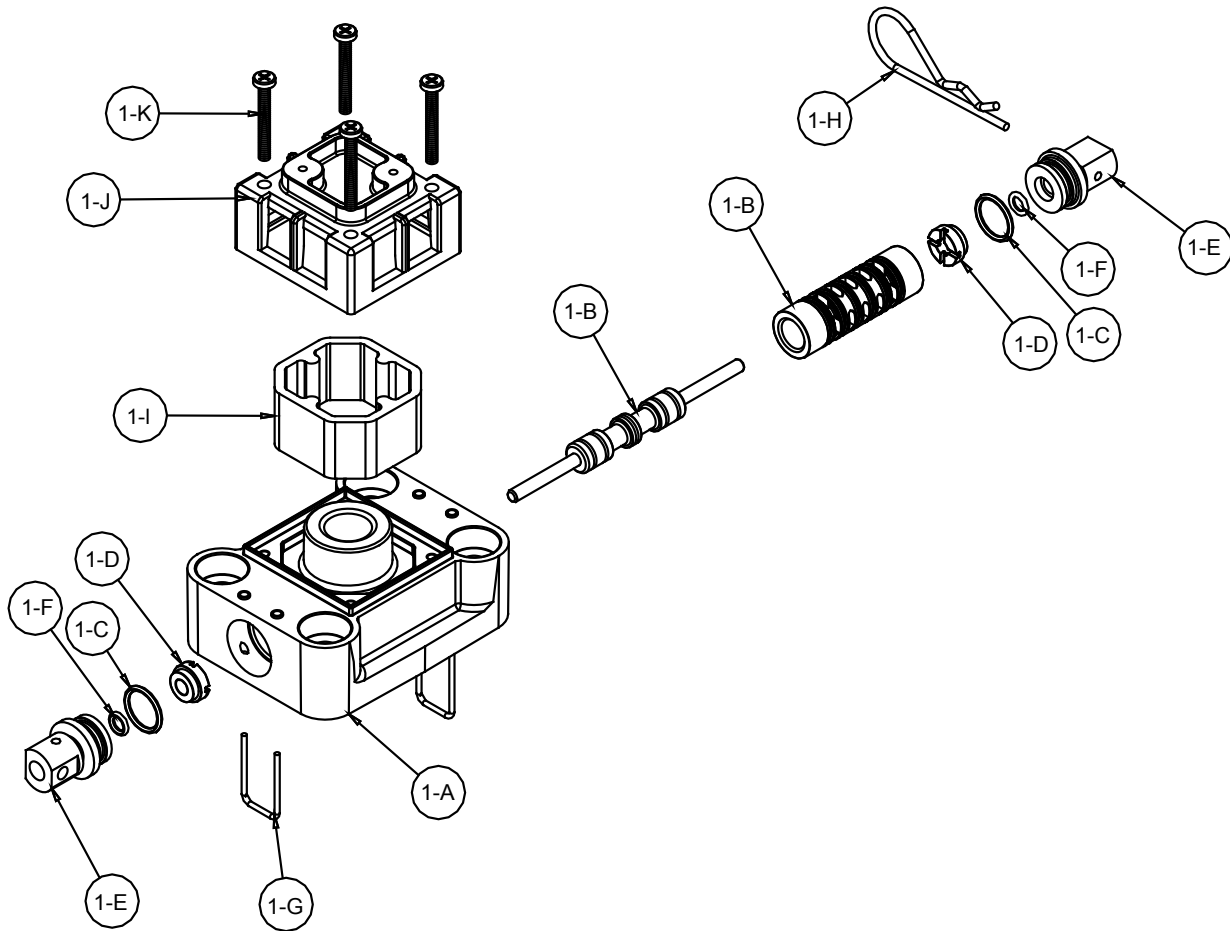

## Air Distribution Valve Servicing

See repair parts drawing, remove screws.

**Step 1:** Remove end cap retainer (1-G).

**Step 2:** Remove end cap (1-E), bumper (1-D).

**Step 3:** Remove spool part of (1-B) (caution, do not scratch).

**Step 4:** Press sleeve (1-B) from body (1-A).

**Step 5:** Inspect O-Rings (1-C) and replace if necessary.

**Step 6:** Lightly lubricate O-Rings (1-C) on sleeve (1-B).

**Step 7:** Press sleeve (1-B) into body (1-A).

**Step 8:** Reassemble in reverse order.

**Note:** Sleeve and spool (1-B) set is match ground to a specified clearance sleeve and spools (1-B) cannot be interchanged.

## Main Air Valve Assembly Parts List

Item	Part Number	Description	Qty
▲ 1	031.167.000	Air Valve Assembly	1
1-A	095.106.559	Body, Air Valve	1
1-B	031.134.000	Sleeve and Spool Set	1
1-C	560.101.360	O-Ring	8
1-D	132.030.552	Bumper	2
1-E	165.123.147	End Cap	2
1-F	560.029.360	O-Ring	2
1-G	675.062.115	End Cap Retainer	2
1-H	210.008.330	Safety Clip	1
1-I	530.031.550	Muffler	1
1-J	165.109.559	Muffler Cap	1
1-K	710.011.115	Self-Tapping Screw	4

### For Pumps with Virgin PTFE coated hardware:

1	031.167.002	Air Valve Assembly	1
1-G	675.062.308	End Cap Retainer	2
1-J	710.011.308	Self Tapping Screw	4

(Includes all other items used on 031.166.000 above)

### For Pumps with alternate Mesh Muffler or Piped Exhaust:

▲ 1	031.169.000	Air Valve Assembly	1
-----	-------------	--------------------	---

(Includes all items used on 031.167.000 above minus 1-H, 1-I and 1-J)



▲ ATEX Compliant

# Pilot Valve Assembly

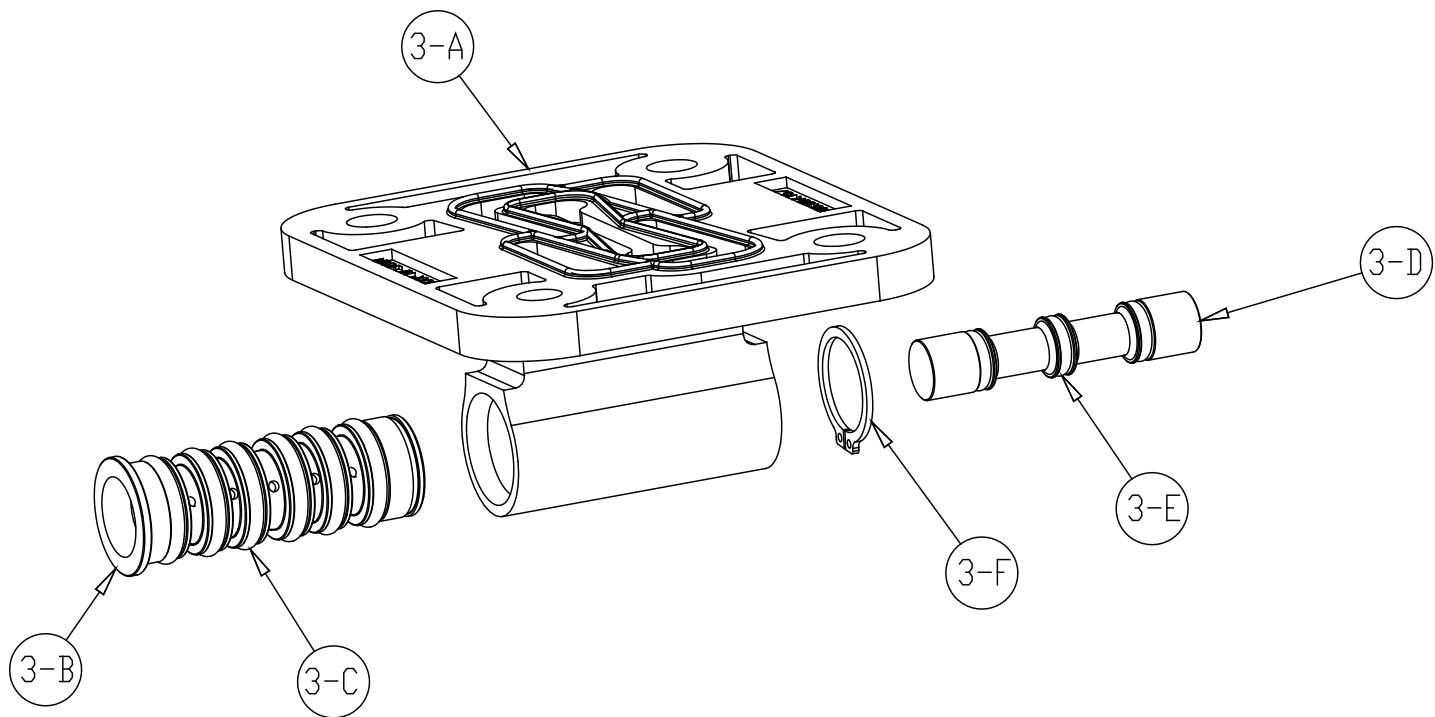

4: AIR END

## Pilot Valve Servicing

With Pilot Valve removed from pump.

**Step 1:** Remove snap ring (3-F).

**Step 2:** Remove sleeve (3-B), inspect O-Rings (3-C), replace if required.

**Step 3:** Remove spool (3-D) from sleeve (3-B), inspect O-Rings (3E), replace if required.

**Step 4:** Lightly lubricate O-Rings (3-C) and (3-E).

Reassemble in reverse order.

## Pilot Valve Assembly Parts List

### For Models Equipped with Aluminum Midsections

Item	Part Number	Description	Qty
3	095.116.000	Pilot Valve Assembly	1
3-A	095.087.157	Valve Body	1
3-B	755.051.000	Sleeve (With O-Rings)	1
3-C	560.033.360	O-Ring (Sleeve)	6
3-D	775.055.000	Spool (With O-Rings)	1
3-E	560.023.360	O-Ring (Spool)	3
3-F	675.037.080	Retaining Ring	1

### For Models Equipped with Polypropylene Midsections

Item	Part Number	Description	Qty
3	095.091.000	Pilot Valve Assembly	1
3-A	095.087.551	Pilot Valve Body	1
3-B	755.051.000	Sleeve (With O-Rings)	1
3-C	560.033.360	O-Ring (Sleeve)	6
3-D	775.055.000	Spool (With O-Rings)	1
3-E	560.023.360	O-Ring (Spool)	3
3-F	675.037.080	Retaining Ring	1

### For Models Equipped with Conductive Polypropylene Midsections

Item	Part Number	Description	Qty
3	095.091.001	Pilot Valve Assembly	1
3-A	095.087.558	Pilot Valve Body	1
3-B	755.051.000	Sleeve (With O-Rings)	1
3-C	560.033.360	O-Ring (Sleeve)	6
3-D	775.055.000	Spool (With O-Rings)	1
3-E	560.023.360	O-Ring (Spool)	3
3-F	675.037.080	Retaining Ring	1

# Intermediate Assembly

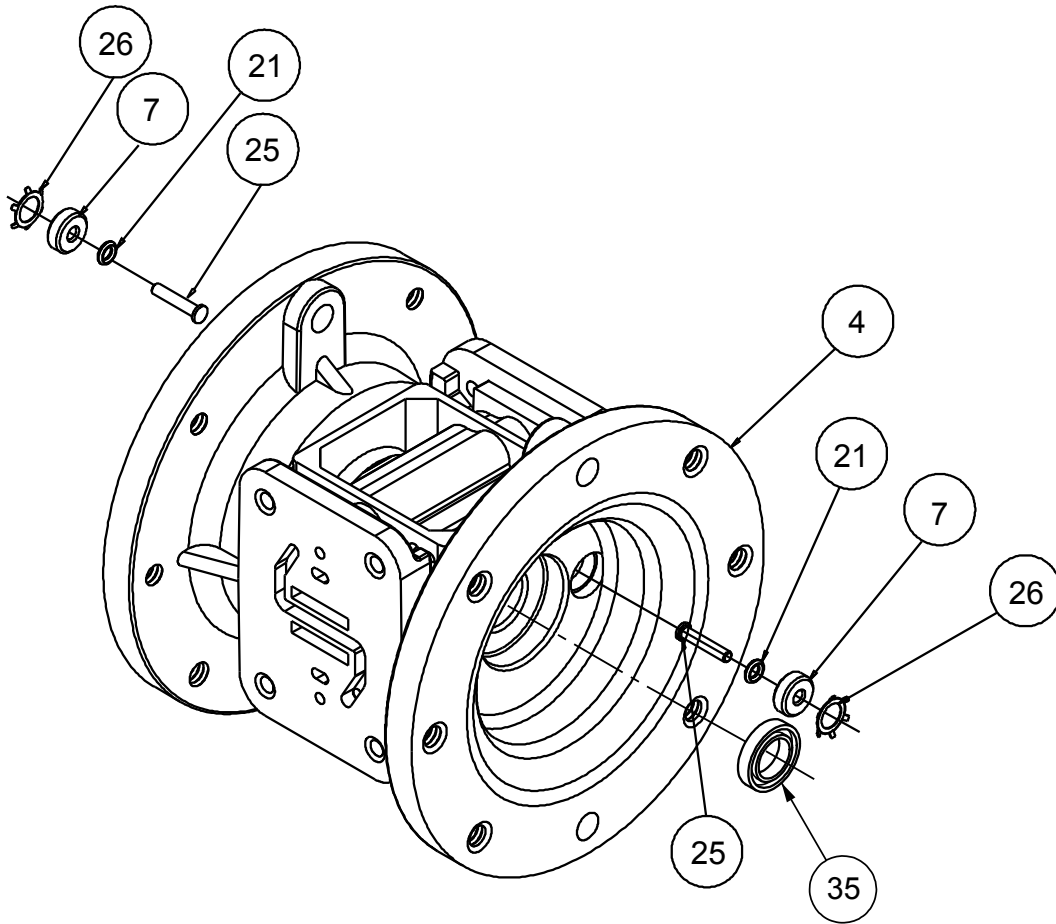

## Intermediate Assembly Drawing

- Step 1:** Remove plunger, actuator (25) from center of intermediate pilot valve cavity.
- Step 2:** Remove Ring, Retaining (26), discard.
- Step 3:** Remove bushing, plunger (7), inspect for wear and replace if necessary with genuine parts.
- Step 4:** Remove O-Ring (21), inspect for wear and replace if necessary with genuine parts.
- Step 5:** Lightly lubricate O-Ring (21) and insert into intermediate.
- Step 6:** Utilizing a new Ring, Retaining (26) reassemble in reverse order
- Step 7:** Remove Seal, Diaphragm Rod (35).
- Step 8:** Clean seal area, lightly lubricate and install new Seal, Diaphragm Rod (28).

## Intermediate Repair Parts List

Item	Part Number	Description	Qty
4	▲ 114.023.157	Bracket, Intermediate	1
	114.023.551	Bracket, Intermediate	1
	▲ 114.023.559	Bracket, Intermediate (Conductive Polypropylene Midsection ONLY)	1
7	135.036.506	Bushing, Plunger	2
28	560.001.360	O-Ring	2
32	620.019.115	Plunger, Actuator	2
33	675.042.115	Ring, Retaining*	2
35	720.012.360	Seal, Diaphragm Rod	2

\*Note: It is recommended that when plunger components are serviced, new retaining rings be installed.

**Ex** **!** **ATEX Compliant**

**! IMPORTANT**



*When the pumped product source is at a higher level than the pump (flooded suction condition), pipe the exhaust higher than the product source to prevent siphoning spills. In the event of a diaphragm failure a complete rebuild of the center section is recommended.*

# Diaphragm Service Drawing

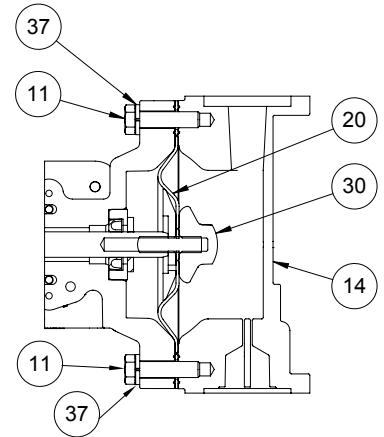
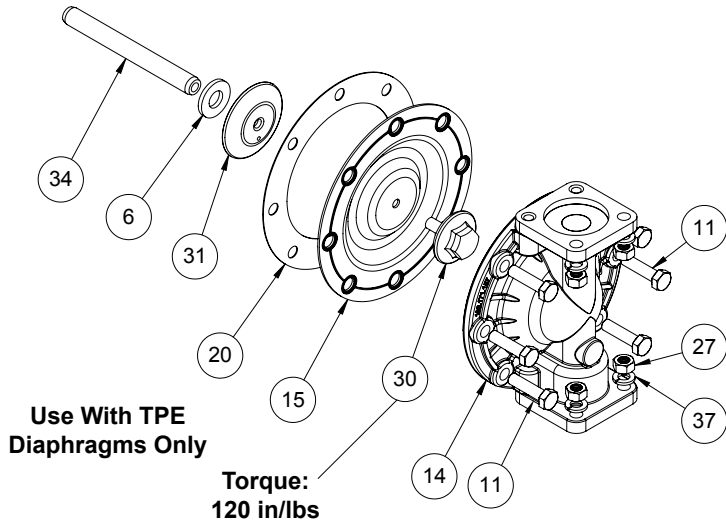

## Diaphragm Orientation

Install diaphragm and spacer as shown above.

# Diaphragm Service Drawing - with Overlay

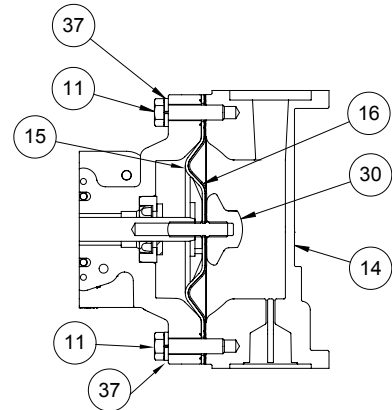
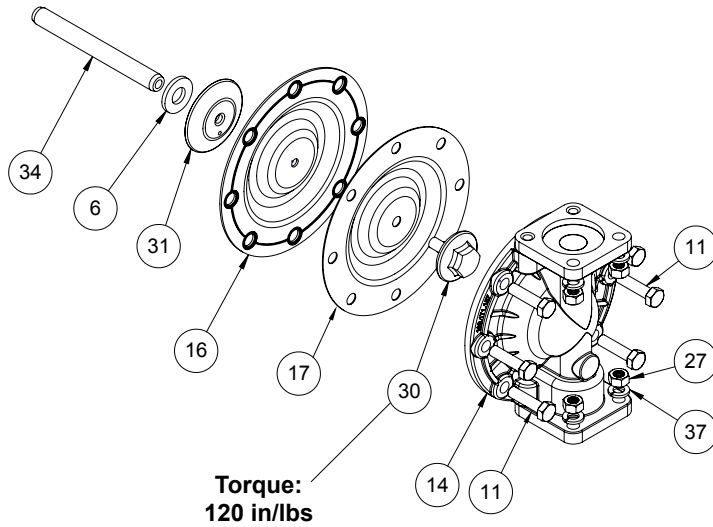

## Diaphragm Orientation

Install diaphragm and spacer as shown above.

# Diaphragm Service Drawing - with One-Piece Bonded

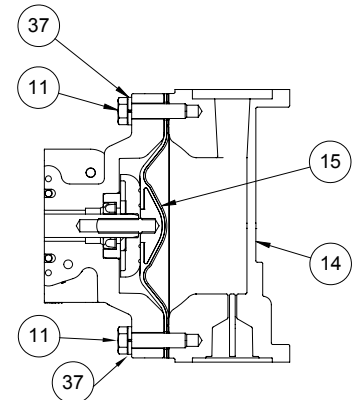
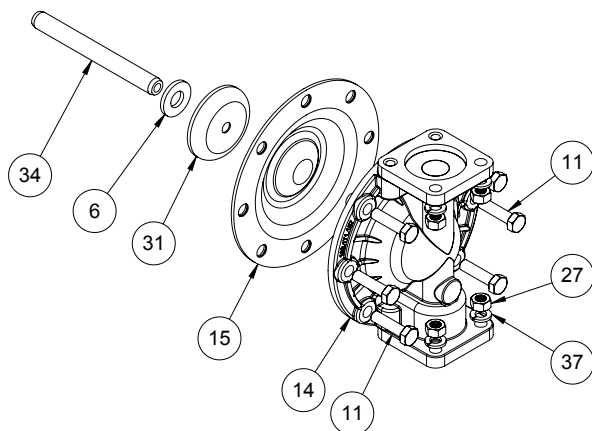

## Diaphragm Orientation

Install diaphragm and spacer as shown above.



# Diaphragm Servicing

**Step 1:** With manifolds and outer chambers removed, remove diaphragm assemblies from diaphragm rod. **DO NOT** use a pipe wrench or similar tool to remove assembly from rod. Flaws in the rod surface may damage bearings and seal. Soft jaws in a vise are recommended to prevent diaphragm rod damage.

**Step 1.A: NOTE:** Not all inner diaphragm plates are threaded. Some models utilize a through hole in the inner diaphragm plate. If required to separate diaphragm assembly, place assembly in a vise, gripping on the exterior cast diameter of the inner plate. Turn the outer plate clockwise to separate the assembly.

Always inspect diaphragms for wear cracks or chemical attack. Inspect inner and outer plates for deformities, rust scale and wear. Inspect intermediate bearings for elongation and wear. Inspect diaphragm rod for wear or marks.

Clean or repair if appropriate. Replace as required.

**Step 2:** Reassembly: There are two different types of diaphragm plate assemblies utilized throughout the Sandpiper product line: Outer plate with a threaded stud, diaphragm, and a threaded inner plate.

Outer plate with a threaded stud, diaphragm, and an inner plate with through hole. Secure threaded inner plate in a vise. Ensure that the plates are being installed with the outer radius against the diaphragm.

**Step 3:** Lightly lubricate, with a compatible material, the inner faces of both outer and inner diaphragm plates when using on non Overlay diaphragms (For EPDM water is recommended). No lubrication is required.

**Step 4:** Push the threaded outer diaphragm plate through the center hole of the diaphragm.

**Note:** Most diaphragms are installed with the natural bulge out towards the fluid side. S05, S07, and S10 non-metallic units are installed with the natural bulge in towards the air side.

**Step 5:** Thread or place, outer plate stud into the inner plate. For threaded inner plates, use a torque wrench to tighten the assembly together. Torque values are called out on the exploded view.

Repeat procedure for second side assembly. Allow a minimum of 15 minutes to elapse after torquing, then re-torque the assembly to compensate for stress relaxation in the clamped assembly.

**Step 6:** Thread one assembly onto the diaphragm rod with sealing washer (when used) and bumper.

**Step 7:** Install diaphragm rod assembly into pump and secure by installing the outer chamber in place and tightening the capscrews.

**Step 8:** On opposite side of pump, thread the remaining assembly onto the diaphragm rod. Using a torque wrench, tighten the assembly to the diaphragm rod. Align diaphragm through bolt holes, always going forward past the recommended torque. Torque values are called out on the exploded view. **NEVER** reverse to align holes, if alignment cannot be achieved without damage to diaphragm, loosen complete assemblies, rotate diaphragm and reassemble as described above.

**Step 9:** Complete assembly of entire unit.

One Piece Diaphragm Servicing (Bonded PTFE with integral plate) The One Piece diaphragm has a threaded stud installed in the integral plate at the factory. The inner diaphragm plate has a through hole instead of a threaded hole. Place the inner plate over the diaphragm stud and thread the first diaphragm / inner plate onto the diaphragm rod only until the inner plate contacts the rod. Do not tighten. A small amount of grease may be applied between the inner plate and the diaphragm to facilitate assembly. Insert the diaphragm / rod assembly into the pump and install the outer chamber. Turn the pump over and thread the second diaphragm / inner plate onto the diaphragm rod. Turn the diaphragm until the inner plate contacts the rod and hand tighten the assembly. Continue tightening until the bolt holes align with the inner chamber holes. **DO NOT LEAVE THE ASSEMBLY LOOSE.**

## IMPORTANT



*Read these instructions completely, before installation and start-up. It is the responsibility of the purchaser to retain this manual for reference. Failure to comply with the recommendations stated in this manual will damage the pump, and void factory warranty.*

# Solenoid Shifted Air Valve

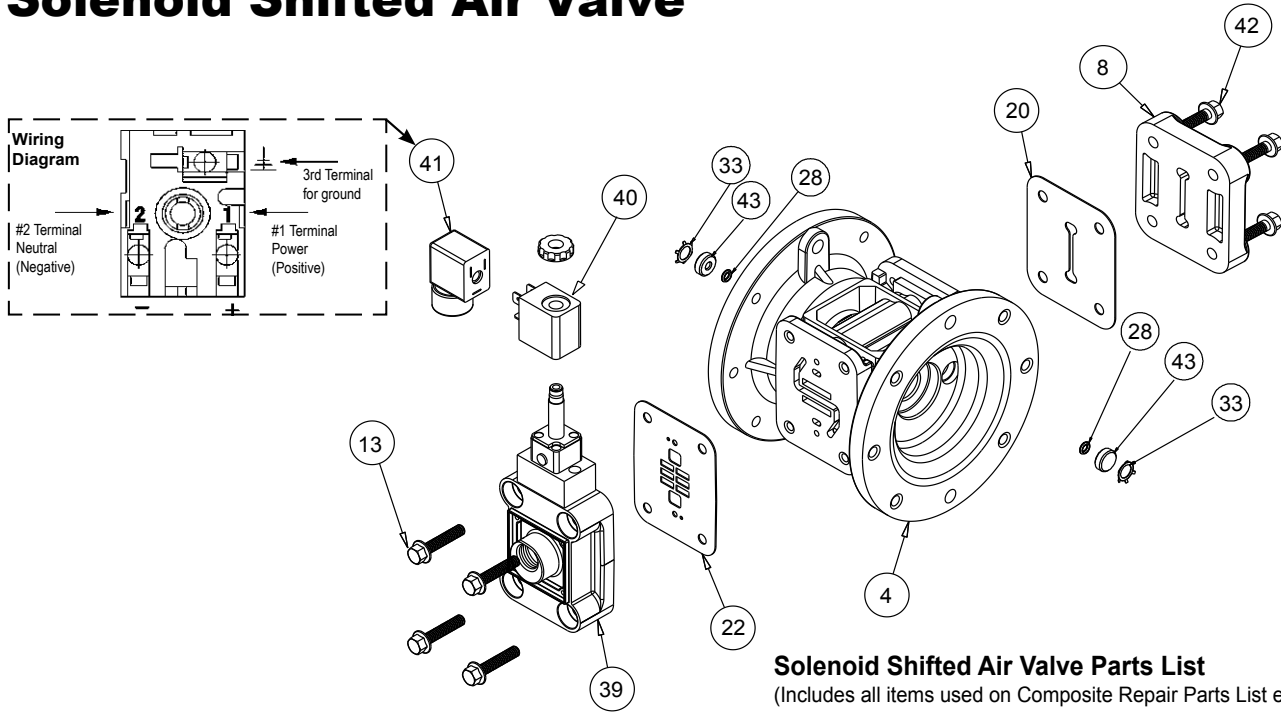

## Solenoid Shifted Air Valve Parts List

(Includes all items used on Composite Repair Parts List except as shown)

Item	Part Number	Description	Qty
4	114.023.157	Bracket, Intermediate	1
	114.023.551	Bracket, Intermediate	1
	114.023.559	Bracket, Intermediate	1
		(Conductive Polypropylene Midsection ONLY)	
39	893.099.000	Solenoid Valve, NEMA4	1
40	219.001.000	Solenoid Coil, 24VDC	1
	219.004.000	Solenoid Coil, 24VAC/12VDC	1
	219.002.000	Solenoid Coil, 120VAC	1
	219.003.000	Solenoid Coil, 240VAC	1
41	241.001.000	Connector, conduit	1
42	171.065.115	Capscrew, Flanged 1/4-20 x 1.00	4
43	618.050.150	Plug (Replaces Item 7)	2



IEC EEx m T4



**△ For Explosion Proof Solenoid Coils used in North America and outside the European Union.**

40	219.009.001	Solenoid Coil, 120VAC 60 Hz	1
	219.009.002	Solenoid Coil, 240VAC 60 Hz	1
	219.009.003	Solenoid Coil, 12VDC	1
	219.009.004	Solenoid Coil, 24VDC	1
	219.009.005	Solenoid Coil, 110VAC 50 Hz	1
	219.009.006	Solenoid Coil, 230VAC 50 Hz	1

**Note: Item 41 (Conduit Connector) is not required**

## Solenoid Shifted Air Distribution Valve Option

Warren Rupp's solenoid shifted, air distribution valve option utilizes electrical signals to precisely control your SANDPIPER's speed. The solenoid coil is connected to a customer - supplied control. Compressed air provides the pumping power, while electrical signals control pump speed (pumping rate).

## Operation

The Solenoid Shifted SANDPIPER has a solenoid operated, air distribution valve in place of the standard SANDPIPER's pilot operated, air distribution valve. Where a pilot valve is normally utilized to cycle the pump's air distribution valve, an electric solenoid is utilized. As the solenoid is powered, one of the pump's air chambers is pressurized while the other chamber is exhausted. When electric power is turned off, the solenoid shifts and the pressurized chamber is exhausted while the other chamber is pressurized. By alternately applying and removing power to the solenoid, the pump cycles much like a standard SANDPIPER pump, with one exception. This option provides a way to precisely control and monitor pump speed.

## Before Installation

Before wiring the solenoid, make certain it is compatible with your system voltage.

## \*Special Conditions For Safe Use

A fuse corresponding to its rated current (max. 3\*I<sub>rated</sub> according IEC 60127-2-1) or a motor protecting switch with short-circuit and thermal instantaneous tripping (set to rated current) shall be connected in series to each solenoid as short circuit protection. For very low rated currents of the solenoid the fuse of lowest current value according to the indicated IEC standard will be sufficient. The fuse may be accommodated in the associated supply unit or shall be separately arranged. The rated voltage to the fuse shall be equal to or greater than the stated rated voltage of the magnet coil. The breakage capacity of the fuse-link shall be as high as or higher than the maximum expected short circuit current at the location of the installation (usually 1500 A). A maximum permissible ripple of 20% is valid for all magnets of direct-current design.



II 2G EEx m c II T5  
II 2D c IP65 T100°C



**For ATEX Compliant Solenoid Coils used in the European Union**

40	219.011.001	Solenoid Coil, Single mounting 12 VDC, 3.3W / 267mA	1
	219.011.002	Solenoid Coil, Single mounting 24 VDC, 3.3W / 136mA	1
	219.011.003	Solenoid Coil, Single mounting 110/120 VAC, 3.4W / 29mA	1
	219.011.004	Solenoid Coil, Single mounting 220/240 VAC, 3.4W / 15mA	1

**Note: Item 41 (Conduit Connector) is not required**

**Compressed Air Temperature Range:** Maximum Ambient Temperature to plus 50°C

# Dual Port (Aluminum Model Only)

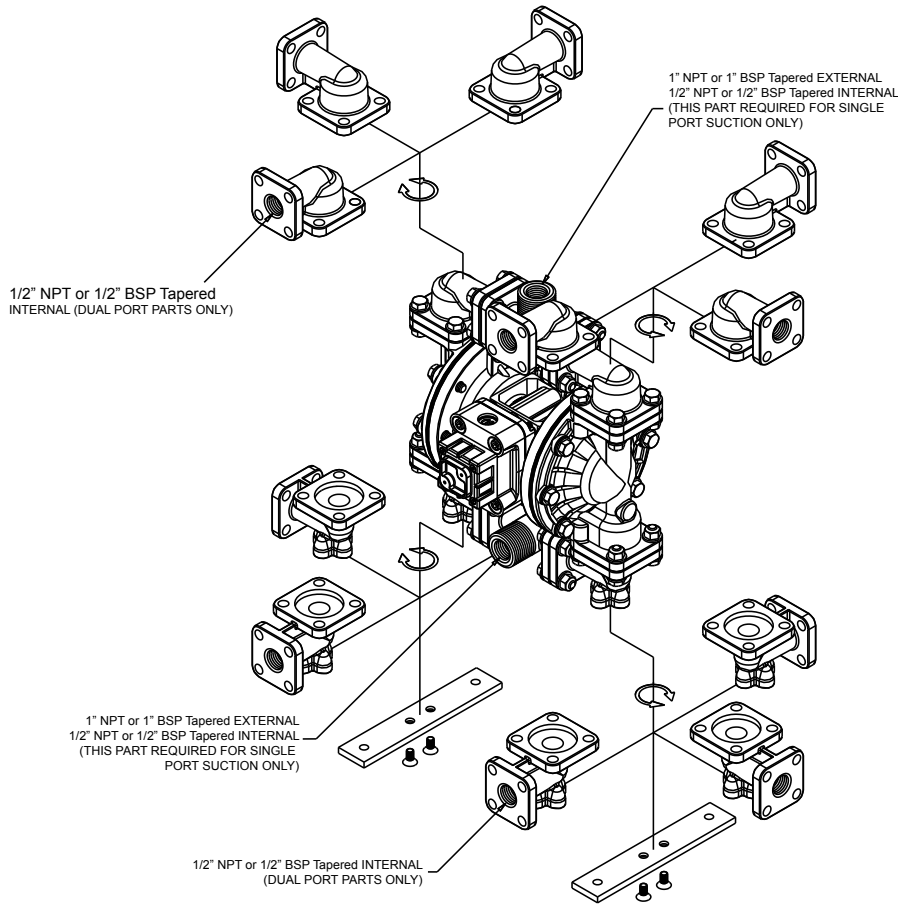

## Illustration for Dual Port Suction and Single or Dual Port Discharge

(Not available for Stainless Steel or Alloy-C Equipped Models)

\*Dual suction/dual discharge = no manifold.

### Dual Port Suction and Discharge Repair Parts List

Item	Part Number	Description	Qty.
10*	170.045.115	Capscrew, Hex 5/16-18 X 1.25	24
	170.045.330	Capscrew, Hex 5/16-18 X 1.25	24
17*	312.110.157E	Elbow, Suction BSP (tapered) (replaces 312.110.157)	2
	312.110.157N	Elbow, Suction 1/2" NPT (replaces 312.110.157)	2
18*	312.111.157E	Elbow, Discharge BSP (tapered) (replaces 312.111.157)	2
	312.111.157N	Elbow, Discharge 1/2" NPT (replaces 312.111.157)	2
23*	518.157.157	Manifold (not required)	0
27*	545.004.115	Nut, Hex 5/16.18	20
	545.004.330	Nut, Hex 5/16.18	20
29*	560.083.360	O-Ring (Alum Manifold) (not required)	0
	560.083.363	O-Ring (Alum Manifold) (not required)	0
	560.083.364	O-Ring (Alum Manifold) (not required)	0
	560.083.365	O-Ring (Alum Manifold) (not required)	0
	720.064.600	Seal (Alum Manifold) (not required)	0
37*	900.004.115	Lock Washer	32
	900.004.330	Lock Washer	32

  **ATEX Compliant**

### IMPORTANT



Read these instructions completely, before installation and start-up. It is the responsibility of the purchaser to retain this manual for reference. Failure to comply with the recommendations stated in this manual will damage the pump, and void factory warranty.

# 5 - YEAR Limited Product Warranty

Warren Rupp, Inc. ("Warren Rupp") warrants to the original end-use purchaser that no product sold by Warren Rupp that bears a Warren Rupp brand shall fail under normal use and service due to a defect in material or workmanship within five years from the date of shipment from Warren Rupp's factory. Warren Rupp brands include Warren Rupp®, SANDPIPER®, MARATHON®, PortaPump®, SludgeMaster™ and Tranquilizer®.

~ See [sandpiperpump.com/content/warranty-certifications](http://sandpiperpump.com/content/warranty-certifications) for complete warranty, including terms and conditions, limitations and exclusions. ~

**WARREN  
RUPP, INC.**

## Declaration of Conformity

Manufacturer: Warren Rupp, Inc., 800 N. Main Street  
Mansfield, Ohio, 44902 USA

Certifies that Air-Operated Double Diaphragm Pump Series: HDB, HDF, M Non-Metallic, S Non-Metallic, M Metallic, S Metallic, T Series, G Series, U Series, EH and SH High Pressure, RS Series, W Series, SMA and SPA Submersibles, and Tranquilizer® Surge Suppressors comply with the European Community Directive 2006/42/EC on Machinery, according to Annex VIII. This product has used Harmonized Standard EN809:1998+A1:2009, Pumps and Pump Units for Liquids - Common Safety Requirements, to verify conformance.

David Roseberry  
Signature of authorized person

David Roseberry  
Printed name of authorized person

Revision Level: F

October 20, 2005  
Date of issue

Engineering Manager  
Title

August 23, 2012  
Date of revision



# **WARREN RUPP, INC.**

## **EC / EU Declaration of Conformity**

The objective of the declaration described is in conformity with the relevant Union harmonisation legislation: Directive 94/9/EC (until April 19, 2016) and Directive 2014/34/EU (from April 20, 2016).

**Manufacturer:**

Warren Rupp, Inc.  
A Unit of IDEX Corporation  
800 North Main Street  
P.O. Box 1568  
Mansfield, OH 44902 USA

**Applicable Standard:**

EN13463-1: 2001  
EN13463-5: 2003  
EN60079-25: 2004

**Harmonised Standard:**

EN13463-1: 2009  
EN13463-5: 2011  
EN60079-25:2010

The harmonised standards have been compared to the applicable standards used for certification purposes and no changes in the state of the art technical knowledge apply to the listed equipment.

**AODD Pumps and Surge Suppressors**

Technical File No.: 203104000-1410/MER

**AODD (Air-Operated Double Diaphragm) Pumps**

EC Type Examination Certificate No. Pumps: KEMA 09ATEX0071 X

DEKRA Certification B.V. (0344)  
Meander 1051  
6825 MJ Arnhem  
The Netherlands

**Hazardous Locations Applied:**

I M1 c	II 1 G c T5
II 2 G Ex ia c II CT5	II 1 D c T100°C
II 2 D Ex c iaD 20 IP67 T100°C	II 2 G c T5
II 2 G Eex m c II T5	II 2 D c T100°C
II 2 D c IP65 T100°C	

**SANDPIPER®**  
A WARREN RUPP, INC. BRAND

**Tranquilizer®**

DATE/APPROVAL/TITLE:  
18 March 2016

*David Roseberry*  
David Roseberry, Director of Engineering

**IDEX**