

**Installation & Service**  
177-997B

# **Hydra-Cell<sup>®</sup>**

## **INDUSTRIAL PUMPS**

**T100 Series Low Pressure**  
**Model: T100E**

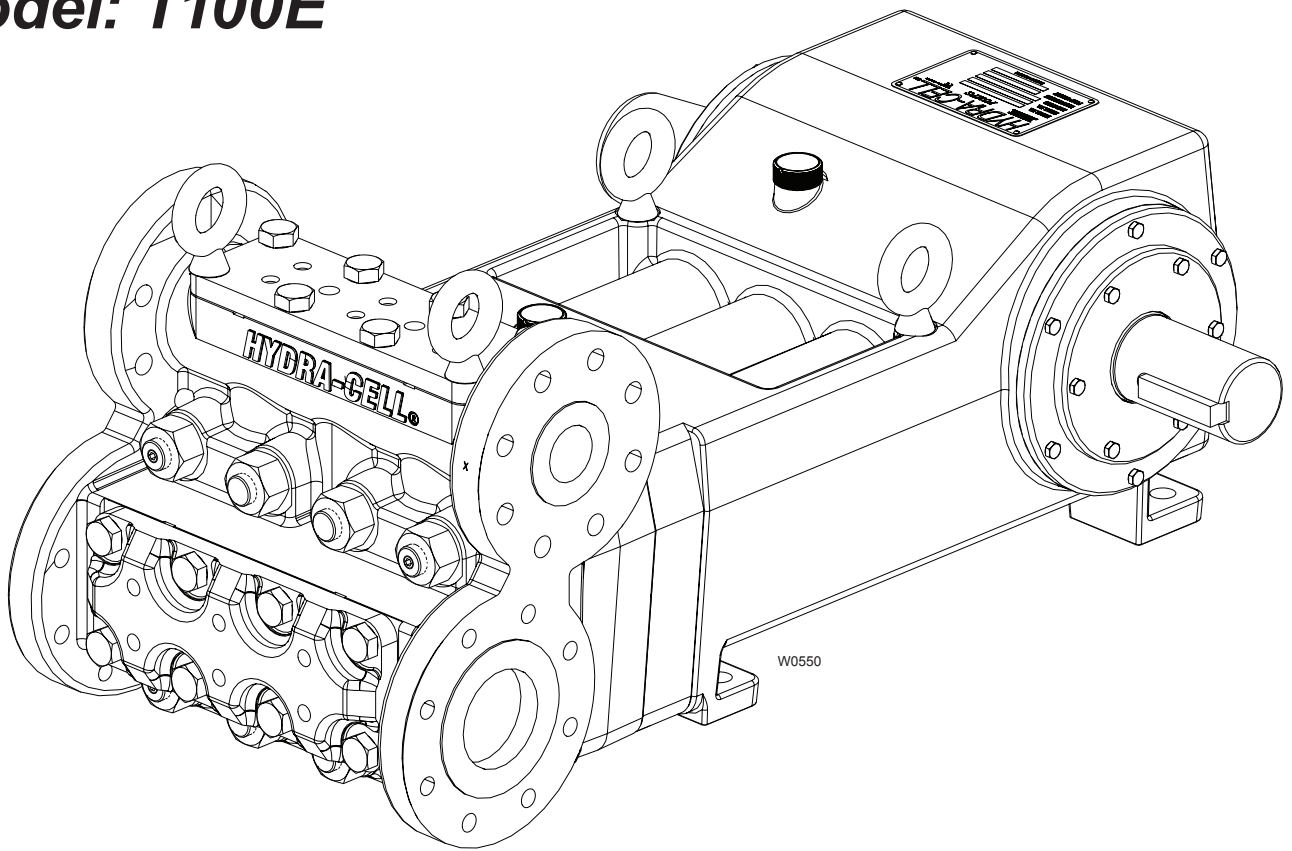

 **Wanner Engineering, Inc.**

1204 Chestnut Avenue, Minneapolis, MN 55403  
Tel: (612) 332-5681 Fax: (612) 332-6937  
Toll-free fax [US only]: (800) 332-6812  
[www.hydra-cell.com/metering](http://www.hydra-cell.com/metering)  
email: [sales@wannereng.com](mailto:sales@wannereng.com)



# T100 Series Low Pressure Contents

	Page
Component Identification .....	2
Specifications .....	2
Dimensions .....	4
Installation .....	6
Maintenance .....	9
Service (Fluid End).....	10
Service (Hydraulic Section).....	12
Service (Power End) .....	18
Troubleshooting .....	21
Torque Specifications.....	22
Fluid End Parts.....	23
Hydraulic Section Parts.....	25
Power End Parts .....	27
T100 Tool Kit Parts.....	29
Pump Storage .....	30
T100E Replacement Parts Kits.....	30
Warranty.....	32

## Component Identification

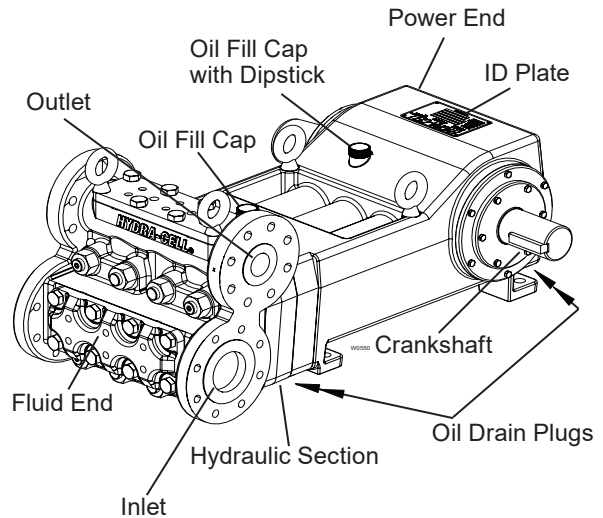

# T100 Series Low Specifications

<b>Maximum Pressure:</b>	1500 psi (103 bar)		
<b>Capacity @ Maximum Pressure</b>	<b>rpm</b>	<b>gpm</b>	<b>l/min</b>
	450	96.0	366.4
<b>Delivery</b>	<b>Pressure psi (bar)</b>	<b>gal/rev</b>	<b>liter/rev</b>
	500 (34)	0.221	0.835
	1000 (69)	0.218	0.825
	1500 (103)	0.215	0.814
<b>Rpm</b>	450 maximum 200 minimum (Consult factory for speeds less than 200)		
<b>Inlet</b>	500 psi (34 bar) pressure maximum		
<b>Fluid Operating Temperatures</b>	Maximum: 180 F (82.2 C) Minimum: 40 F (4.4 C) [contact factory for temperatures outside this range]		
<b>Inlet Ports</b>	3-1/2 inch Class 300 RF ANSI Flange		
<b>Discharge Ports</b>	2 inch Class 900 RF ANSI Flange		
<b>Maximum Solids</b>	1/32 inch (0.8 mm)		
<b>Input Shaft</b>	left or right side		
<b>Shaft Diameter</b>	3.0 inch (76.2 mm)		
<b>Shaft Rotation</b>	Bi-directional		

## T100 Series Low Specifications (Cont'd)

<b>Fluid End Material, Manifold</b>	Nickel Aluminum Bronze, 316 Stainless Steel
<b>Bearings</b>	Spherical Roller/Journal
<b>Elastomers</b>	Buna-N and FKM
<b>Oil Capacity</b>	18 US quarts (17 liters)
<b>Weight (dry)</b>	1100 lbs (499 kg)

## Calculating Required Horsepower (kW)\*

$$\frac{\text{gpm} \times \text{psi}}{1,460} = \text{electric motor HP}^*$$

$$\frac{\text{l/min} \times \text{bar}}{511} = \text{electric motor kW}^*$$

\* HP/kW is required application power.

### Attention!

When sizing motors with variable speed drives (VFDs), it is very important to select a motor and a VFD rated for constant torque inverter duty service and that the motor is rated to meet the torque requirements of the pump throughout desired speed range.

# T100 Series Low Specifications (Cont'd)

## Performance

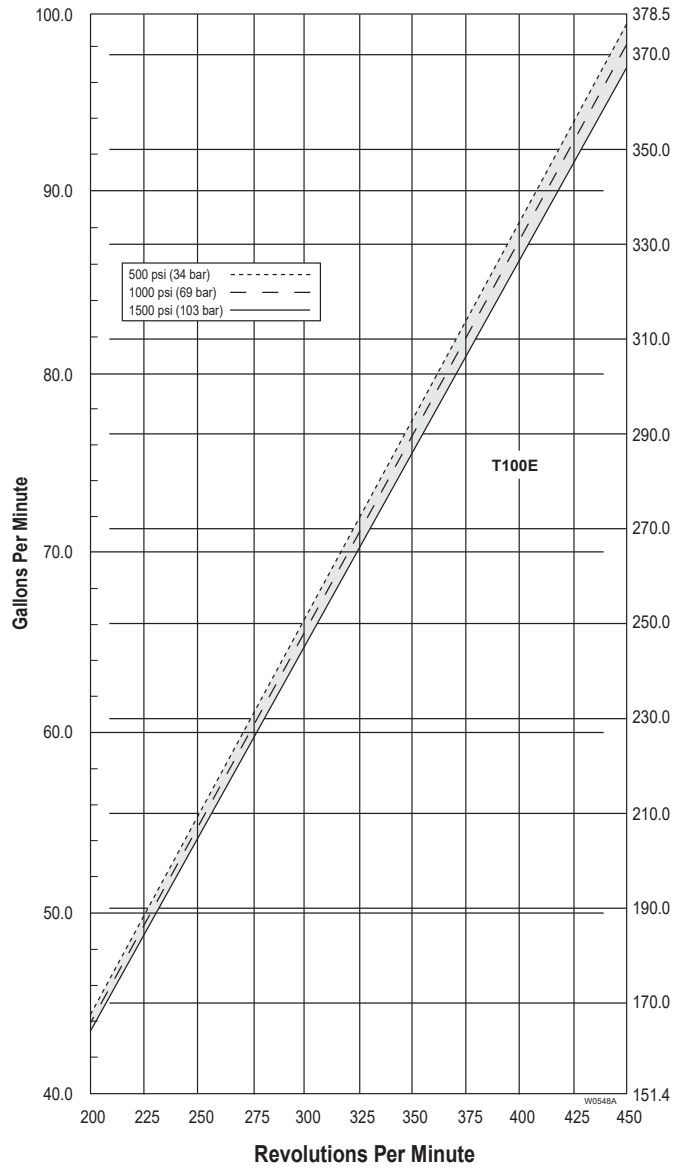

## Net Positive Suction Head – NPSHr

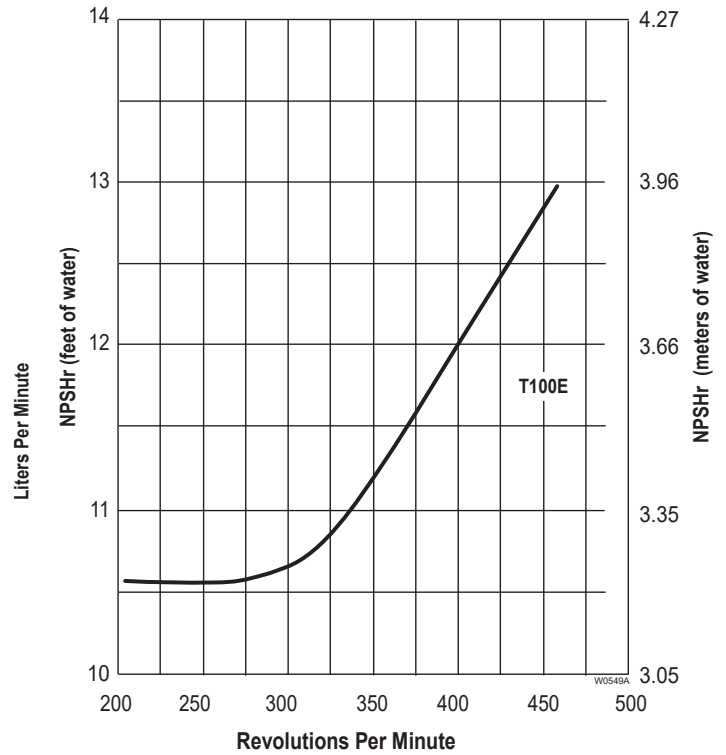

# T100 Series Low Pressure Dimensions

inches  
(mm)

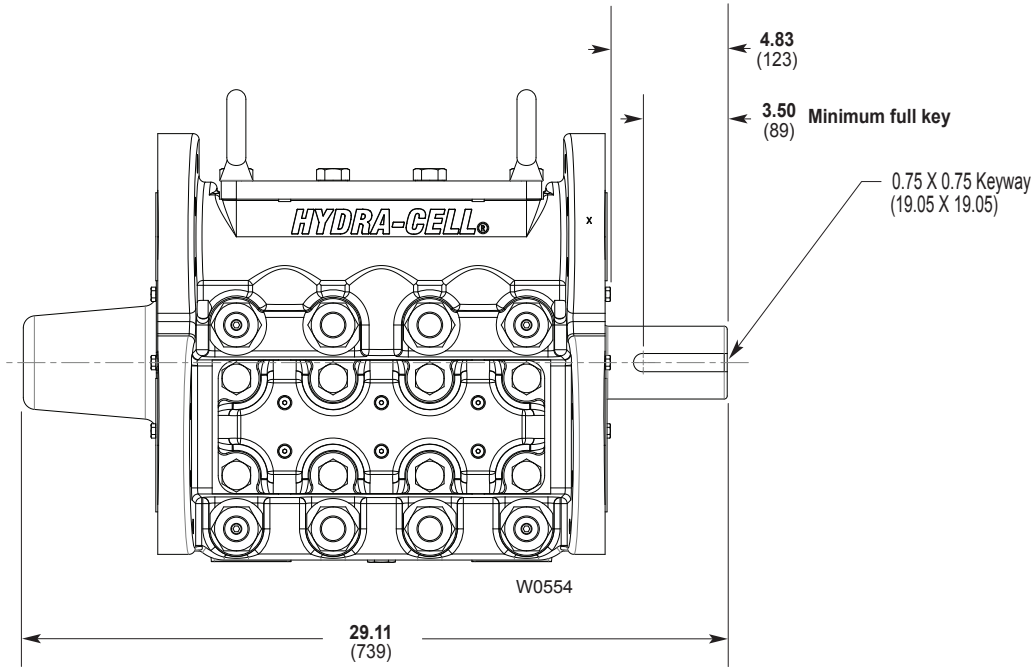

Front View

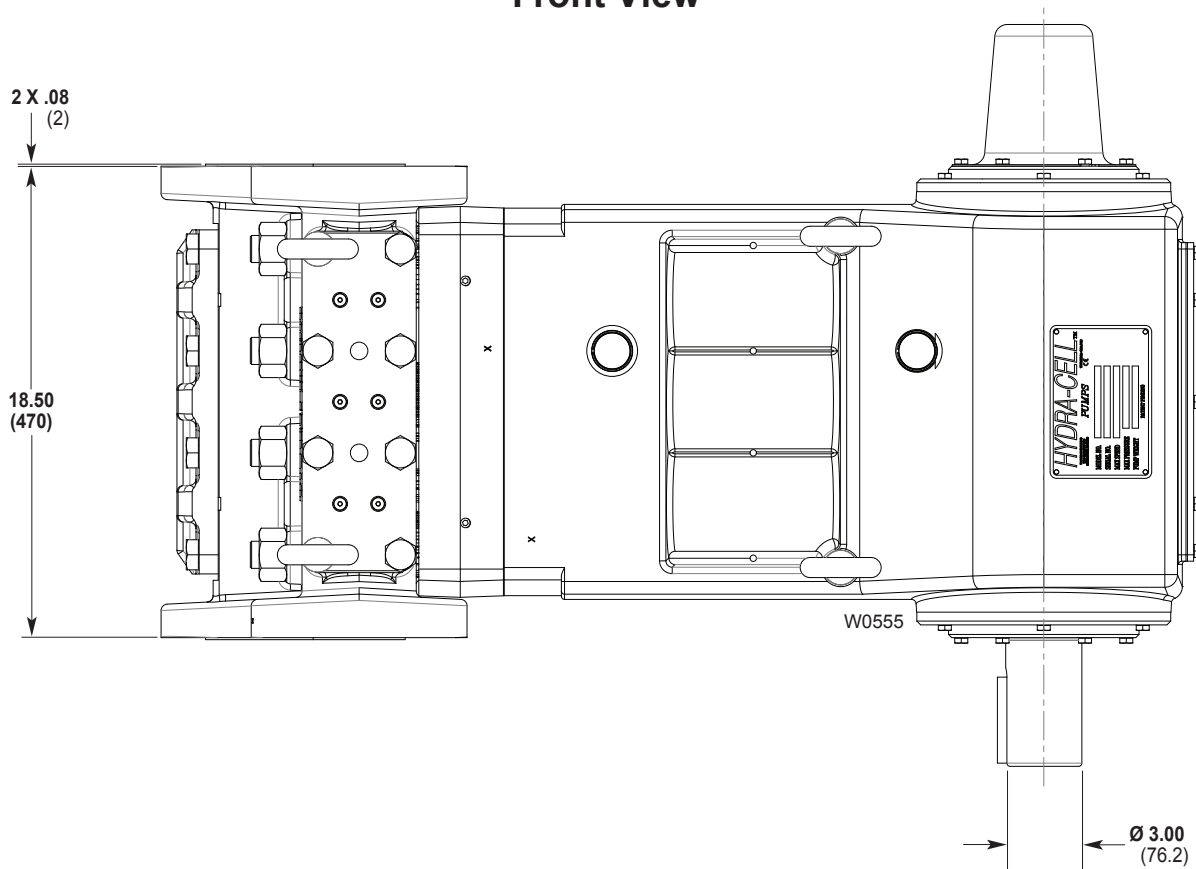

Top View

# T100 Series Low Dimensions (Cont'd)

inches  
(mm)

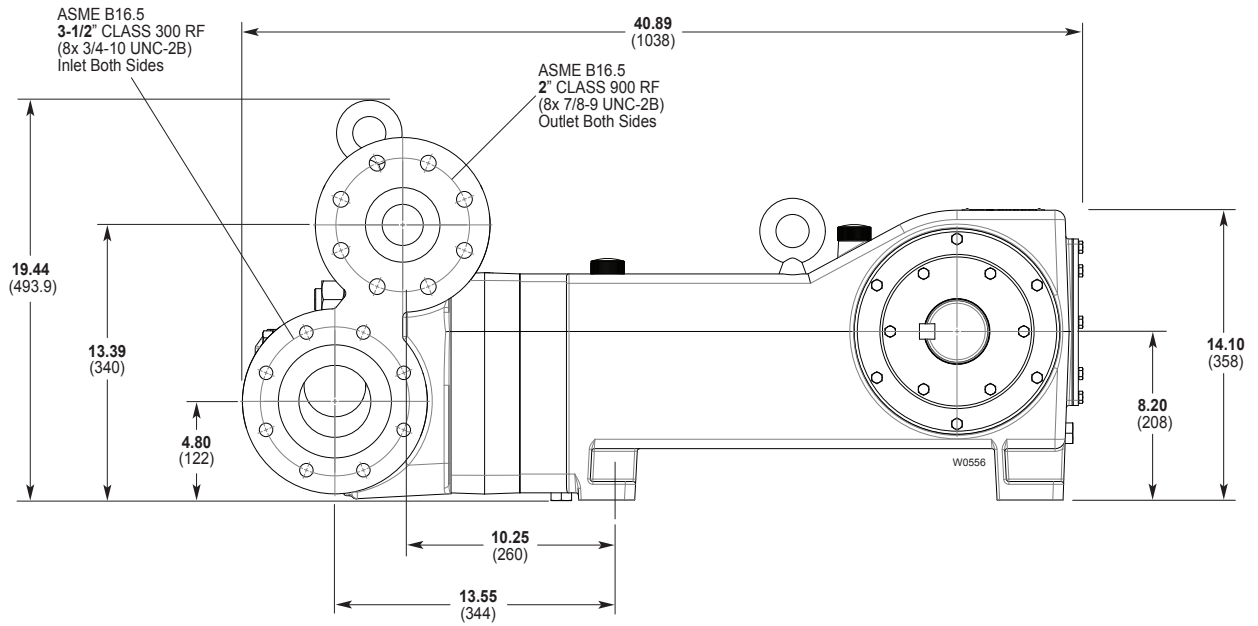

**Side View**

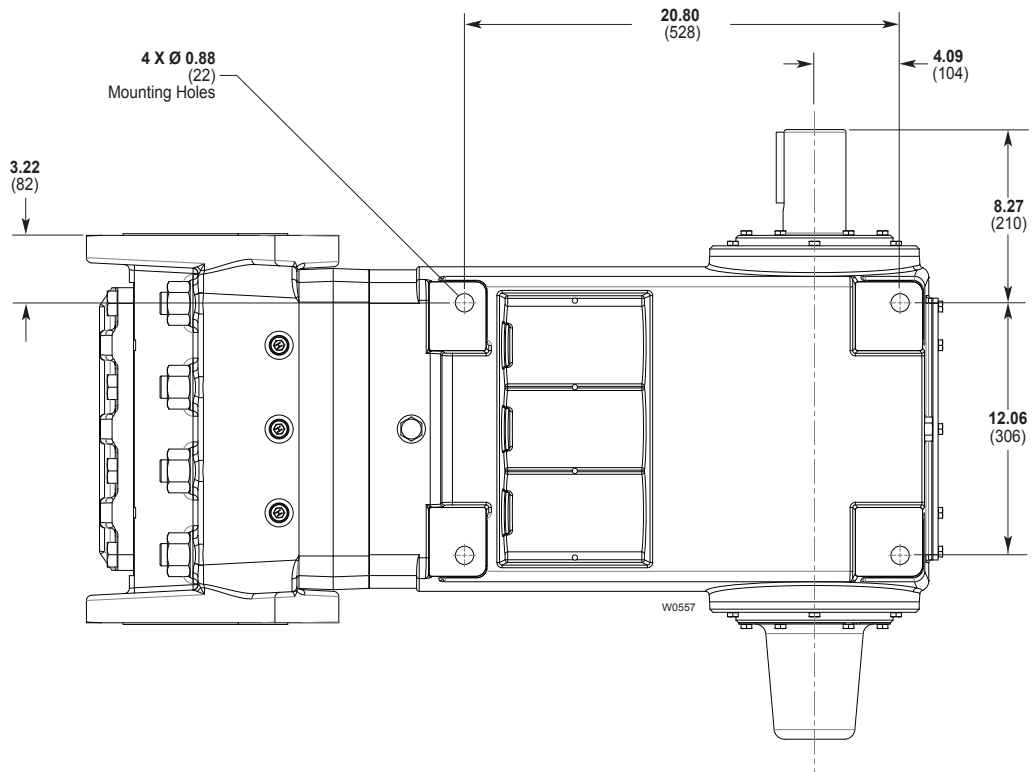

**Bottom View**

# T100 Series Low Pressure Installation

## Location

Locate the pump as close to the fluid supply source as possible.

Install it in a lighted clean space where it will be easy to inspect and maintain. Allow room for checking the oil level, changing the oil (two drain plugs on the bottom and back of pump), and removing the pump head components (inlet and discharge retainer plates, manifold, and related items).

## Mounting

The pump shaft can rotate in either direction.

To prevent vibration, mount the pump and motor securely on a level rigid base.

On a belt-drive system, align the sheaves accurately; poor alignment wastes horsepower and shortens the belt and bearing life. Make sure the belts are properly tightened, as specified by the belt manufacturer.

On a direct-drive system, align the shafts accurately. Unless otherwise specified by the coupling manufacturer, maximum parallel misalignment should not exceed 0.015 in. (0.4 mm) and angular misalignment should be held to 1° maximum. Careful alignment extends life of the coupling, pump, shafts, and support bearings. Consult coupling manufacturer for exact alignment tolerances.

## Accessories

Consult installation drawing below for typical system components. Contact Wanner Engineering or the distributor in your area for more details.

## Important Precautions

**Adequate Fluid Supply.** To avoid cavitation and premature pump failure, be sure that the pump will have an adequate fluid supply and that the inlet line will not be obstructed. See "Inlet Piping" and consult NPSH chart.

**Positive Displacement.** This is a positive-displacement pump. Install a relief valve downstream from the pump. See "Discharge Piping".

**Safety Guards.** Install adequate safety guards over all pulleys, belts, and couplings. Follow all local codes and regulations regarding installation and operation of the pumping system.

**Shut-Off Valves.** Never install shut-off valves between the pump and discharge pressure regulator, relief valve, or in the regulator bypass line.

**Freezing Conditions.** Protect the pump from freezing. See also the Maintenance Section.

**Vacuum at Outlet.** Do not allow a vacuum at the pump outlet during shutdown. A vacuum can damage the diaphragm at start-up. If there is a vacuum at the pump outlet, allow atmospheric pressure at the outlet for 30 minutes before starting. Wanner Engineering recommends installing an outlet check valve with a 65 psi (4.5 bar) cracking pressure to prevent a vacuum condition during shutdown.

### Consult the Factory for the following situations:

- Fluid temperature applications – above 180° F (82° C) or below 40° F (4.4° C)
- Pressure feeding of pumps over 500 psig (34.5 bar)
- Viscous fluid applications above 100 Cps
- Chemical compatibility problems
- Hot ambient temperatures – above 110° F (43° C)
- Conditions where pump oil may exceed 200° F (93° C) because of a combination of hot ambient temperatures, hot fluid temperature, and full horsepower load — an oil cooler may be required
- Pump rpm less than 200

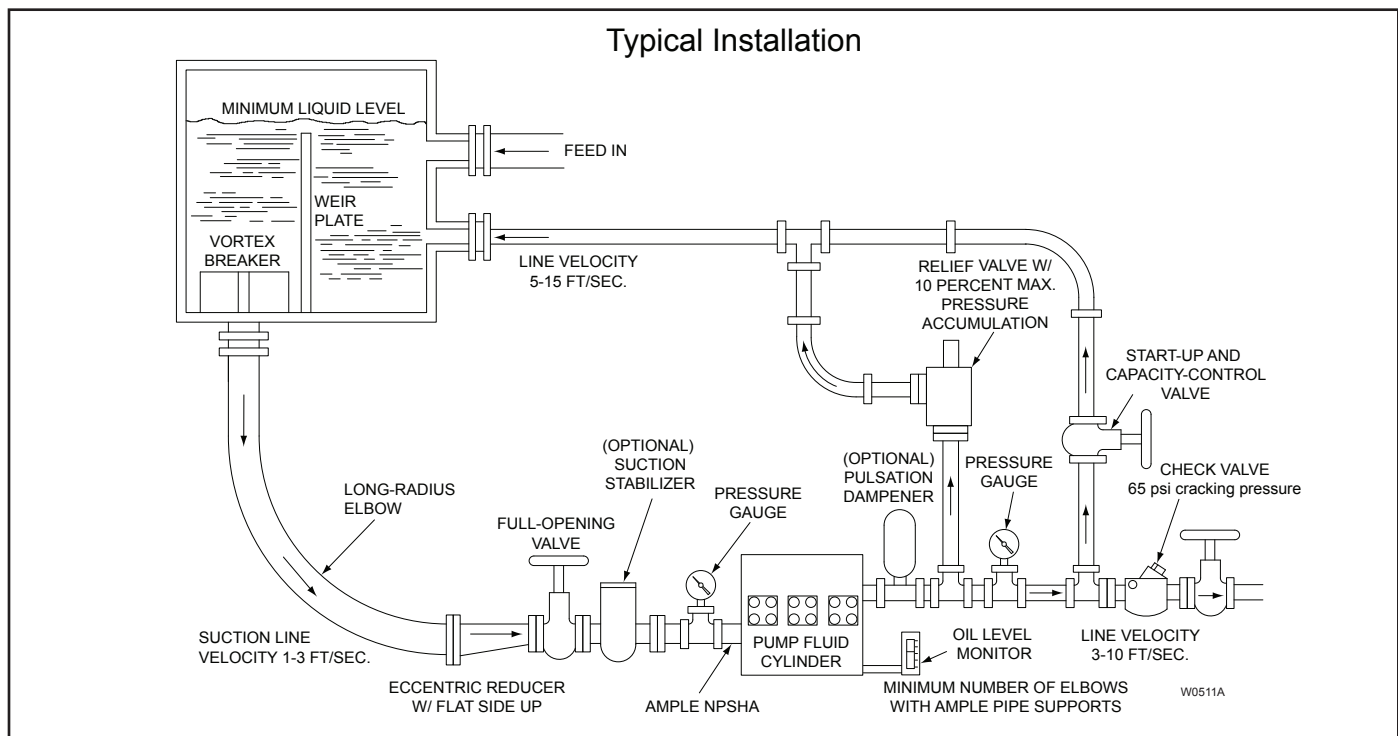

# T100 Series Low Installation (Cont'd)

## Inlet Piping (Suction Feed)

Install drain cocks at any low points of the suction line, to permit draining in freezing conditions.

Provide for permanent or temporary installation of a vacuum gauge to monitor the inlet suction. To maintain maximum flow, NPSHA must exceed NPSHR (See chart in Specifications Section). **Do not supply more than one pump from the same inlet line if possible.**

### Supply Tank

Use a supply tank that is large enough to provide time for any trapped air in the fluid to escape. The tank size should be at least five times the maximum pump flow rate (in gpm or lpm). *For example: at a maximum rate of 96 gpm, since trapped air takes five minutes to escape from water, and with a 96 gpm flow rate:  $5 \times 96 = 480$  gallons for a recommended supply tank size.*

Isolate the pump and motor stand from the supply tank, and support them separately.

Install a separate inlet line from the supply tank to each pump.

Install the inlet and bypass lines so they empty into the supply tank below the lowest water level, on the opposite side of the baffle from the pump suction line.

If a line strainer is used in the system install it in the inlet line to the supply tank.

To reduce aeration and turbulence, install a completely submerged baffle plate to separate the incoming and outgoing liquids.

Install a vortex breaker in the supply tank, over the outlet port to the pump.

Place a cover over the supply tank, to prevent foreign objects from falling into it.

### Hose and Routing

Size the suction line at least one size larger than the pump inlet, and so that the velocity will be 1-3 ft/sec (0.3 to 0.9 m/s):

For pipe in inches: Velocity (ft/sec) =  $0.408 \times \text{GPM}/\text{Pipe ID}^2$

For pipe in mm: Velocity (m/sec) =  $21.2 \times \text{LPM}/\text{Pipe ID}^2$

Keep the suction line as short and direct as possible.

Use flexible hose and/or expansion joints to absorb vibration, expansion, or contraction.

If possible, keep suction line level. Do not have any high points collecting vapor unless high points are vented.

To reduce turbulence and resistance, do not use 90° elbows. If turns are necessary in the suction line, use 45° elbows or arrange sweeping curves in the flexible inlet hose.

If a block valve is used, be sure it is fully opened so that the flow to the pump is not restricted. The opening should be at least the same diameter as the inlet plumbing ID.

Do not use a line strainer or filter in the suction line unless regular maintenance is assured. If used, choose a top loading basket. It should have a free-flow area of at least three times the free-flow area of the inlet.

Install piping supports where necessary to relieve strain on the inlet line and to minimize vibration.

## Inlet Piping (Pressure Feed)

Provide for permanent or temporary installation of a vacuum/pressure gauge to monitor the inlet vacuum or pressure. Pressure at the pump inlet should not exceed 500 psi (34.5 bar); if it could get higher, install an inlet pressure reducing regulator. Do not supply more than one pump from the same inlet line.

## Inlet Calculations

### Acceleration Head

#### Calculating the Acceleration Head

Use the following formula to calculate acceleration head losses. Subtract this figure from the NPSHa, and compare the result to the NPSHr of the Hydra-Cell pump.

$$H_a = (L \times V \times N \times C) \div (K \times G)$$

where:

$H_a$  = Acceleration head (ft of liquid)

$L$  = Actual length of suction line (ft) — not equivalent length

$V$  = Velocity of liquid in suction line (ft/sec) [ $V = \text{GPM} \times (0.408 \div \text{pipe ID}^2)$ ]

$N$  = rpm of crank shaft

$C$  = Constant determined by type of pump — use 0.066 for the T100E Hydra-Cell pumps

$K$  = Constant to compensate for compressibility of the fluid — use: 1.4 for de-aerated or hot water; 1.5 for most liquids; 2.5 for hydrocarbons with high compressibility

$G$  = Gravitational constant (32.2 ft/sec<sup>2</sup>)

### Friction Losses

#### Calculating Friction Losses in Suction Piping

When following the above recommendations (under “Inlet Piping”) for minimum hose/pipe I. D. and maximum length, frictional losses in the suction piping are negligible (i.e.,  $H_f = 0$ ) if you are pumping a water-like fluid.

When pumping more-viscous fluids such as lubricating oils, sealants, adhesives, syrups, varnishes, etc.; frictional losses in the suction piping may become significant. As  $H_f$  increases, the available NPSH (NPSHa) will decrease, and cavitation will occur.

In general, frictional losses increase with increasing viscosity, increasing suction-line length, increasing pump flow rate, and decreasing suction-line diameter. Changes in suction-line diameter have the greatest impact on frictional losses: a 25% increase in suction-line diameter cuts losses by more than two times, and a 50% increase cuts losses by a factor of five times.

Consult the factory before pumping viscous fluids.

#### Minimizing Acceleration Head and Frictional Losses

To minimize the acceleration head and frictional losses:

- Keep inlet lines less than 6 ft (1.8 m) or as short as possible
- Use at least 4 in. (102 mm) I.D. inlet hose
- Use **suction** hose (low-pressure hose, non collapsing) for the inlet lines
- Minimize fittings (elbows, valves, tees, etc.)
- **Use a suction stabilizer on the inlet.**



# T100 Series Low Installation (Cont'd)

## Net Positive Suction Head

NPSHa must be equal to or greater than NPSHr. If not, the pressure in the pump inlet will be lower than the vapor pressure of the fluid — and cavitation will occur.

### Calculating the NPSHa

Use the following formula to calculate the NPSHa:

$$\text{NPSHa} = P_t + H_z - H_f - H_a - P_{vp}$$

where:

$P_t$  = Atmospheric pressure

$H_z$  = Vertical distance from surface liquid to pump center line (if liquid is below pump center line, the  $H_z$  is negative)

$H_f$  = Friction losses in suction piping

$H_a$  = Acceleration head at pump suction

$P_{vp}$  = Absolute vapor pressure of liquid at pumping temperature

Notes:

- In good practice, NPSHa should be 2 ft greater than NPSHr
- All values must be expressed in feet of liquid

### Atmospheric Pressure at Various Altitudes

Altitude (ft)	Pressure (ft of H <sub>2</sub> O)	Altitude (ft)	Pressure (ft of H <sub>2</sub> O)
0	33.9	1500	32.1
500	33.3	2000	31.5
1000	32.8	5000	28.2

## Discharge Piping

### Hose and Routing

Use the shortest, most-direct route for the discharge line.

Select pipe or hose with a **working pressure** rating of at least 1.5 times the maximum system pressure. EXAMPLE: Select a 1500 psi W.P.-rated hose for systems to be operated at 1000 psi-gauge pressure.

Use flexible hose between the pump and rigid piping to absorb vibration, expansion or contraction.

Support the pump and piping independently. Size the discharge line so that the velocity of the fluid will be 3-10 ft/sec (1-3 m/sec):

For pipe in inches: Velocity (ft/sec) = 0.408 x GPM/Pipe ID<sup>2</sup>

For pipe in mm: Velocity (m/sec) = 21.2 x LPM/Pipe ID<sup>2</sup>

### Pressure Relief

**Install a pressure relief valve in the discharge line.** Bypass pressure must not exceed the pressure limit of the pump.

Size the relief valve so that, when fully open, it will be large enough to relieve the full capacity of the pump without overpressurizing the system.

Locate the valve as close to the pump as possible and ahead of any other valves.

Adjust the pressure relief valve to no more than 10% over the maximum working pressure of the system. Do not exceed the manufacturer's pressure rating for the pump or relief valve.

Route the bypass line to the supply tank. See the diagram showing a typical installation at the beginning of the Installation Section.

If the pump may be run for a long time with the discharge closed and fluid bypassing, install a thermal protector in the bypass line (to prevent severe temperature buildup in the bypassed fluid).

**CAUTION: Never install shutoff valves in the bypass line or between the pump and pressure relief valve.**

Install a pressure gauge in the discharge line.

**Vacuum at Outlet.** Do not allow a vacuum at the pump outlet during shutdown. A vacuum can damage the diaphragm at start-up. If there is a vacuum at the pump outlet, allow atmospheric pressure at the outlet for 30 minutes before starting. Wanner Engineering recommends installing an outlet check valve with a 65 psi cracking pressure to prevent a vacuum condition during shutdown.

**Oil Level Monitoring.** Install an oil level monitor on the pump. The monitor should be connected to both oil drains.

## Before Initial Start-Up

Before you start the pump, be sure that:

- Pump is stored at a temperature between 40-180 F (4.4-82.2 C) for a minimum of 24 hours before start up.
- All shutoff valves are open, and the pump has an adequate supply of fluid.
- All connections are tight.
- The oil level is within the marking on the dipstick. Add oil as needed.
- The relief valve on the pump outlet is adjusted so the pump starts under minimum pressure.
- All shaft couplings or drive pulleys have adequate safety guards.

## Initial Start-Up

1. Pump must be at or above 40 F (4.4 C) for 24 hours prior to starting.
2. Open the bypass line start-up and capacity-control valve so the pump may be started against negligible discharge pressure.
3. Turn on power to the pump motor.
4. Check the inlet pressure or vacuum. To maintain maximum flow, inlet vacuum must not exceed 7 in. Hg at 70° F (180 mm Hg at 21° C). Inlet pressure must not exceed 500 psi (34 bar).
5. Listen for any erratic noise, and look for unsteady flow. If the pump does not clear, refer to the Troubleshooting Section.
6. If the system has an air lock and the pump fails to prime:
  - a. Turn off the power.
  - b. Remove the pressure gauge from the tee fitting at the pump outlet (see installation diagram).

**Note: Fluid may come out of this port when the plug is removed. Provide an adequate catch basin for fluid spillage, if required. Fluid will come out of this port when the pump is started, so we recommend that you attach adequate plumbing from this port so fluid will not be sprayed or lost. Use high-pressure-rated hose and fittings from this port. Take all safety precautions to assure safe handling of the fluid being pumped.**

- c. Jog the system on and off until the fluid coming from this port is air-free.
- d. Turn off the power.
- e. Remove the plumbing that was temporarily installed, and reinstall the pressure gauge or plug.



# T100 Series Low Installation (Cont'd)

## Initial Start-Up (Cont'd)

- Adjust the bypass line valve to the desired operating pressure. Do not exceed the maximum pressure rating of the pump.
- After the system pressure is adjusted, verify the safety relief valve setting by closing the bypass line valve until the relief valve opens.  
**Note: Fluid may come out of the safety relief valve. Provide an adequate catch basin for fluid spillage. Take all safety precautions to assure safe handling of the spillage.**
- Reset the bypass line valve to obtain the desired system pressure.
- Provide a return line from the relief valve to the supply tank, similar to the bypass line.

## Maintenance

**Note: The numbers in parentheses are the Reference Numbers on the exploded view illustrations found in this manual and in the Parts Manual.**

### Daily

Check the oil level and the condition of the oil with the pump turned off. The oil level should be within the marking on the dipstick. Add oil as needed or use continuous monitor.

Use the appropriate Hydra-Oil for the application (contact Wanner Engineering if in doubt).

**CAUTION: If you are losing oil but don't see any external leakage, or if the oil becomes discolored and contaminated, one of the diaphragms (47) may be damaged. Refer to the Fluid-End Service Section. Do not operate the pump with a damaged diaphragm.**

**Do not leave contaminated oil in the pump housing or leave the housing empty. Remove contaminated oil as soon as discovered, and replace it with clean oil.**

### Periodically

**Change the oil after the first 500 hours of operation; and then every 2000 hours or six months, whichever comes first.**

**Note: Hydra-Cell T100 Series Pumps come standard with 10W30 motor oil.**

**Note: Minimum oil viscosity for proper hydraulic end lubrication is 16-20 cST (80-100 SSU) at 212°F (100°C).**

**Use of an oil cooler is recommended when process fluid and/or hydraulic end oil exceeds 180°F (82.2°C).**

When changing oil, remove both drain plugs (14) at the bottom of the pump so all oil and accumulated sediment will drain out.

Check the inlet pressure or vacuum periodically with a gauge. If vacuum at the pump inlet exceeds NPSHR, check the inlet piping system for blockages. If the pump inlet is located above the supply tank, check the fluid supply level and replenish if too low.

## Shutdown Procedure During Freezing Temperatures

**Take all safety precautions to assure safe handling of the fluid being pumped. Provide adequate catch basins for fluid drainage and use appropriate plumbing from drain ports, etc., when flushing the pump and system with a compatible antifreeze. Drain ports are located in the manifold.**

## Recommended Tools and Supplies

The following tools and supplies are recommended for servicing the T100E Pump:

10 mm hex socket with extension

30 mm hex socket

46 mm hex socket

3/4 in. hex socket

8 mm box-end wrench

13 mm open-end wrench

9/16 in. box-end wrench

3 mm hex wrench

4 mm hex wrench

5 mm hex wrench

6 mm hex wrench

8 mm hex wrench

Torx T30

Torx T45

Flathead screwdriver

No. 3 Phillips-head screwdriver

Internal retaining ring pliers

8 in. adjustable wrench

Torque wrench, adjustable from 250 to 450 ft-lbs (339 to 610 N-m)

Pipe wrench

Loctite 242

New Hydra-Oil

Wanner T100 Low Pressure Tool Kit (see T100 Low Pressure Tool Kit Parts)

# T100 Series Low Pressure Fluid End Service

**WARNING:** Manifold (56) and assembled parts weigh over 200 pounds (91 kg) and are a two man lift. Use care in handling to prevent personal injury or damage to equipment.

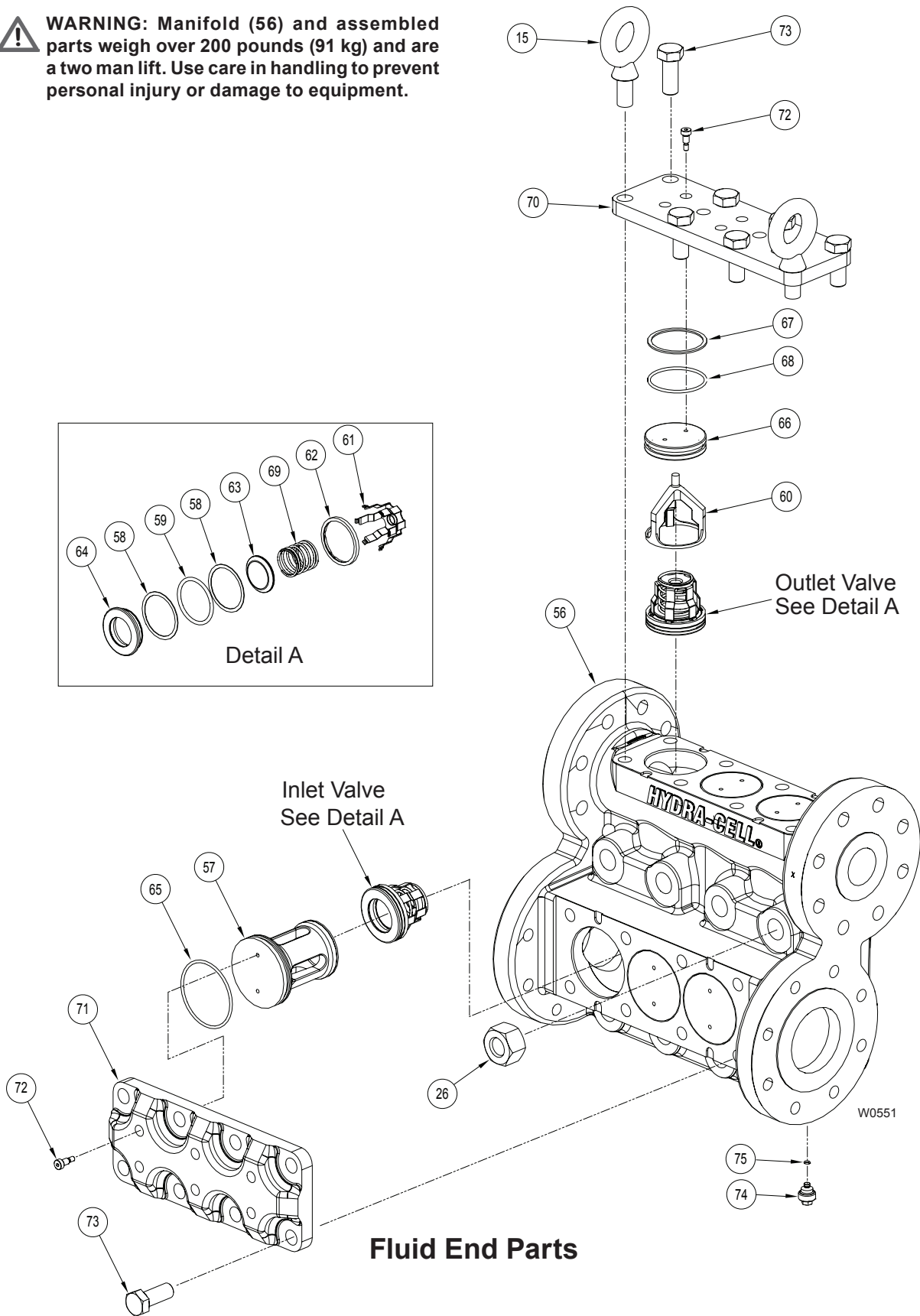
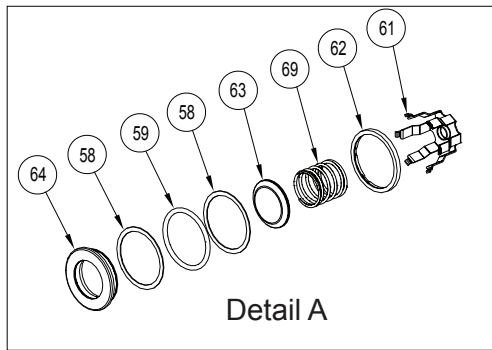

# T100 Series Low Fluid End Service (Cont'd)

This section explains how to disassemble and inspect all easily-serviceable parts of the pump.

**Note: The numbers in parentheses are the Reference Numbers in the Fluid End Parts exploded view illustration in this section and also in the Parts Section.**

## Fluid End Service

### Inlet Check Valve Disassembly

- a. See *Fluid End Parts View*. Remove eight bolts (73) around inlet retainer plate (71).
- b. Remove inlet retainer plate and three inlet retainer plugs (57) with assembled O-rings (65).
- c. Check O-rings and inlet retainer plugs for wear. Replace if worn. Lubricate new O-rings with petroleum jelly or lubricating gel. Each inlet retainer plug is attached to inlet retainer plate with two screws (72).
- d. Inspect inlet retainer plate for warping or wear around inlet ports. Look for corrosion, scale and wear. If wear is excessive, replace inlet retainer plate. Clean inlet retainer plate of any scale and corrosion with Scotch-Brite™ pad or fine emery cloth. Wash after cleaning. To check if inlet retainer plate is warped, place a straightedge across it. A warped inlet retainer plate should be replaced.
- e. Remove three inlet check valve cartridges (58,59,61-64,69) with check valve extraction tool. Tool is included in Wanner Tool Kit.
- f. Inspect each of three check valve cartridges for wear and leakage at seat. Replace inlet check valve cartridges as needed.
- g. Using a light, visually inspect diaphragms through inlet ports. If diaphragms appear abnormal or damaged, remove and replace as instructed in Diaphragm Parts Disassembly.

### Inlet Check Valve Assembly

- a. Reinstall three inlet check valve cartridges (58,59,61-64,69) .
- b. Reinstall inlet retainer plate (71) and inlet retainer plugs (57) with two screws (72) and assembled O-rings (65). Use eight bolts (73) to fasten inlet retainer plate. Hand thread bolts, then tighten from inner to outer. See *Manifold Assembly Torque Sequence Diagram*. Torque to 300 ft-lbs (407 N-m).

### Outlet Check Valve Disassembly

**Note: Removal of Inlet Check Valves first will make removal of Outlet Check Valves easier.**

- a. Remove two eyebolts (15) and six cap screws (73) around discharge retainer plate (70).
- b. Remove discharge retainer plate with assembled outlet valve port plugs (66), backup rings (67), O-rings (68), and outlet valve retainers (60).
- c. Check outlet valve port plugs, backup rings, O-rings, and outlet valve retainers for wear. Replace if worn. Lubricate new O-rings with petroleum jelly or lubricating gel. Outlet valve port plugs are attached to discharge retainers plate with two screws (72).
- d. Inspect discharge retainer plates for warping or wear around discharge ports. Look for corrosion, scale and wear. If wear is excessive, replace discharge retainer plate. Clean discharge retainer plates of any scale and corrosion with Scotch-Brite™ pad or fine emery cloth. Wash after cleaning. To check if discharge retainer plate is warped, place a straightedge across it. A warped discharge retainer plate should be replaced.
- e. Remove three outlet check valve cartridges (58,59,61-64,69) with check valve extraction tool. Tool is included in Wanner Tool Kit.
- f. Inspect each of three check valve cartridges for wear and leakage at seat. Replace outlet check valve cartridges as needed.

### Outlet Check Valve Assembly

- a. Reinstall three outlet check valve cartridges (58,59,61-64,69).
- b. Reinstall discharge retainer plate (70) with assembled outlet valve port plugs (66) with two screws (72) [Torque to 75 in-lbs (8 N-m)], backup rings (67), O-rings (68), and outlet valve retainers (60); using six cap screws (73) and two eyebolts (15). (Check illustration) Hand thread cap screws and eyebolts.
- c. Tighten cap screws from opposing corners to opposing corners of discharge retainer plates. Torque to 300 ft-lbs (407 N-m).
- d. Tighten eyebolts with crow bar or hammer.

### Drain Plug

- a. Remove and replace drain plug (74) and O-ring (75) as needed. Torque drain plug with O-ring to 40 ft-lbs (54 N-m). Apply Loctite nickel anti-seize lubricant to thread and chamfer of plug, with coverage on O-ring.

# T100 Series Low Hydraulic Section Service

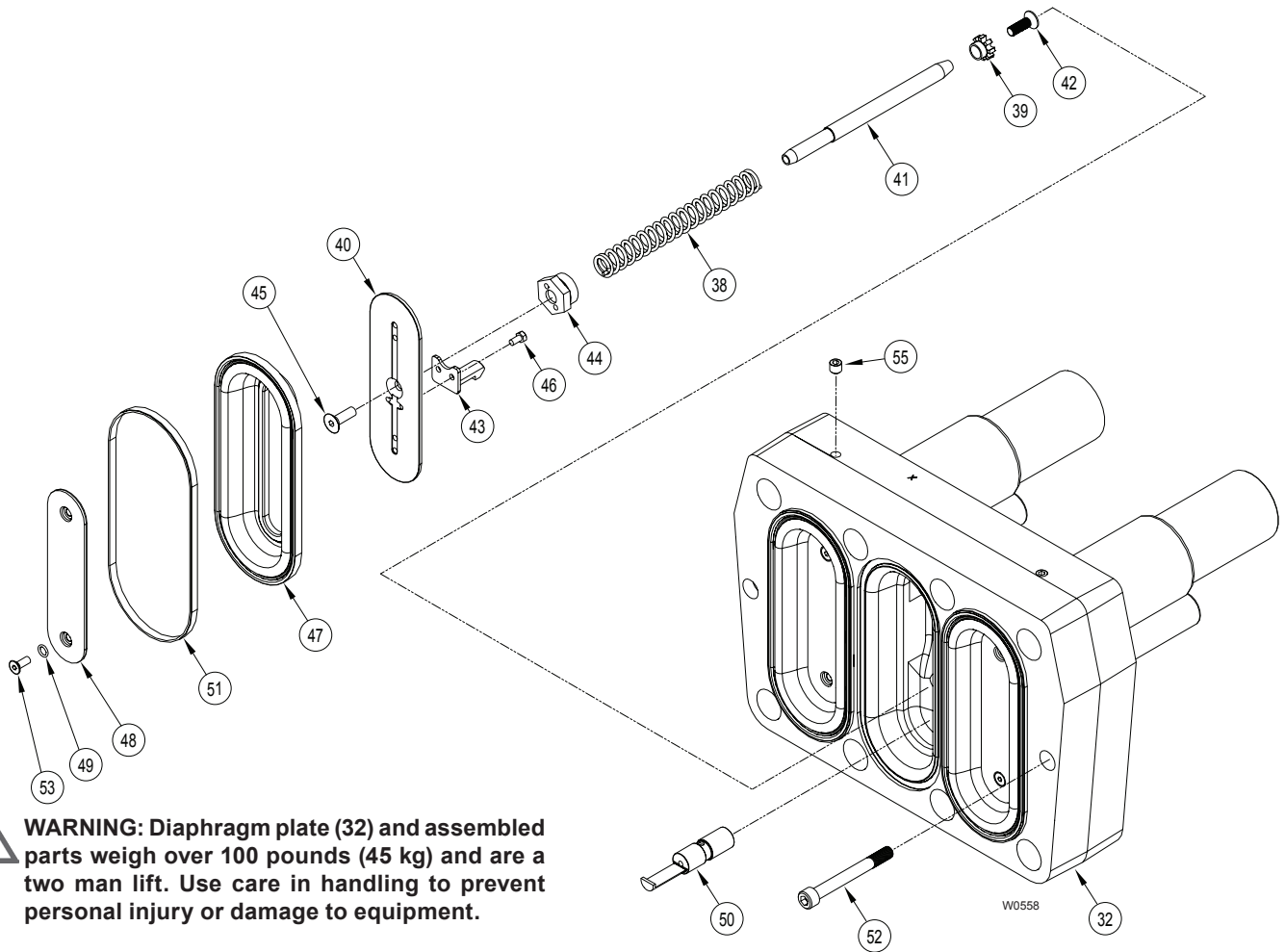

**!** **WARNING:** Diaphragm plate (32) and assembled parts weigh over 100 pounds (45 kg) and are a two man lift. Use care in handling to prevent personal injury or damage to equipment.

## Hydraulic Section Parts

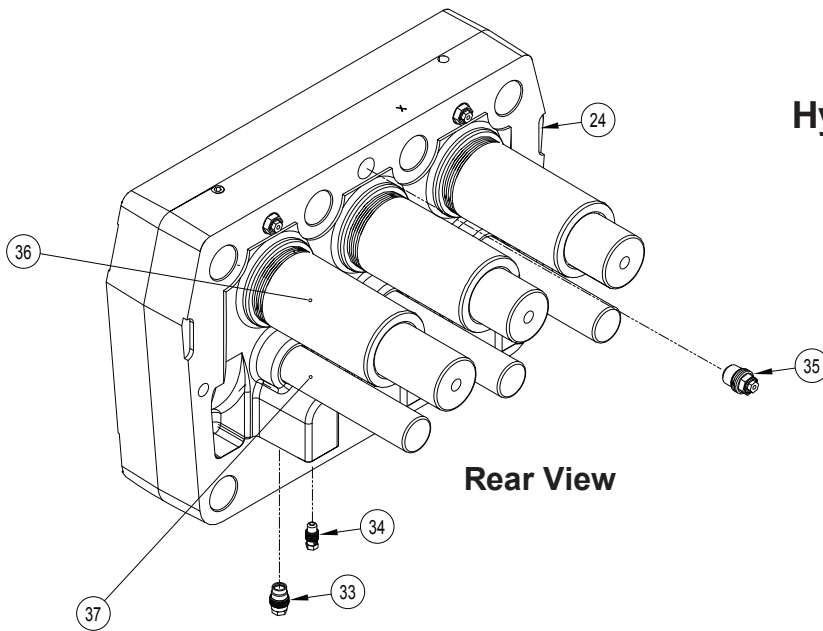

**Rear View**

# T100 Low Hydraulic Section Service (Cont'd)

**Note:** The numbers in parentheses are the Reference Numbers shown in the Hydraulic Section Parts View in this section of the manual and in the Parts Section of the manual.

## Hydraulic Section

### Disassembly

#### Manifold Disassembly

**!** **WARNING:** Manifold (56) and assembled parts weigh over 200 pounds (91 kg) and are a two man lift. Use care in handling to prevent personal injury or damage to equipment.

- See *Power End Parts Illustration in Parts List*. Remove both drain plugs (14) from bottom and back of pump and drain oil into container (capable of holding 18 qts [17 liters] of oil). Dispose of old oil in an approved way.
- Replace drain plugs.
- See *Fluid End Parts View*. Remove eight bolts (73) around inlet retainer plate (71).
- Remove eight hex nuts (26) from fluid end of pump. Install four 177-393 Extender Studs from T100 Tool Kit on studs (21). Carefully slide manifold (56) forward along extender studs to allow access to diaphragm plate (32).

#### Diaphragm Disassembly

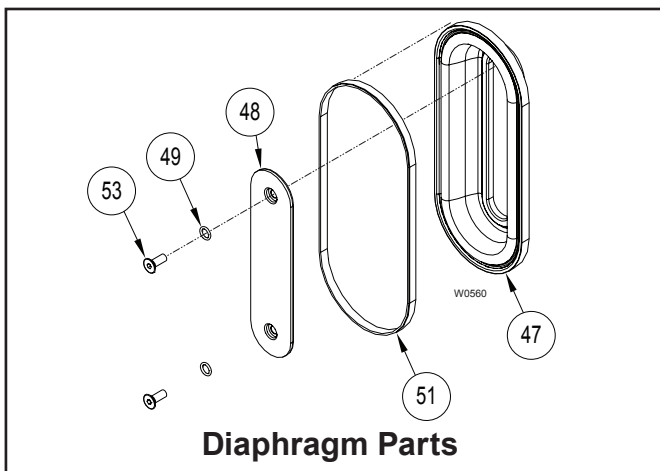

- See *Diaphragm Parts View*. Remove two screws (53), two O-rings (49) and follower (48).

**CAUTION:** If a diaphragm has ruptured and foreign material or water has entered the oil reservoir, do not operate the pump. Check all diaphragms, then flush the reservoir completely and refill it with fresh oil. Never let the pump stand with foreign material or water in the reservoir, or with the reservoir empty.

- Remove the diaphragm (47) and diaphragm back-up ring (51). Inspect diaphragm carefully for any abnormal conditions. A ruptured diaphragm generally indicates a pumping system problem, and replacing only the diaphragm will not solve the larger problem. Inspect the diaphragm for the following:

- Small puncture.** Usually caused by a sharp foreign object in the fluid.
  - Diaphragm pulled away** from the center screw or from the cylinder sides. Usually caused by fluid being frozen in the pump, or by overpressurization of the pump.
  - Diaphragm becoming stiff** and losing flexibility. Usually caused by pumping a fluid that is incompatible with the diaphragm material.
  - Slice in ridge of diaphragm.** Occurs when diaphragm is operated at cold temperatures.
  - Diaphragm torn concentrically in the mid convolute area.** Usually an indication of an outlet vacuum condition.
- If needed replace diaphragm.
  - Replace diaphragm back-up ring if needed.

#### Bias Rod Disassembly

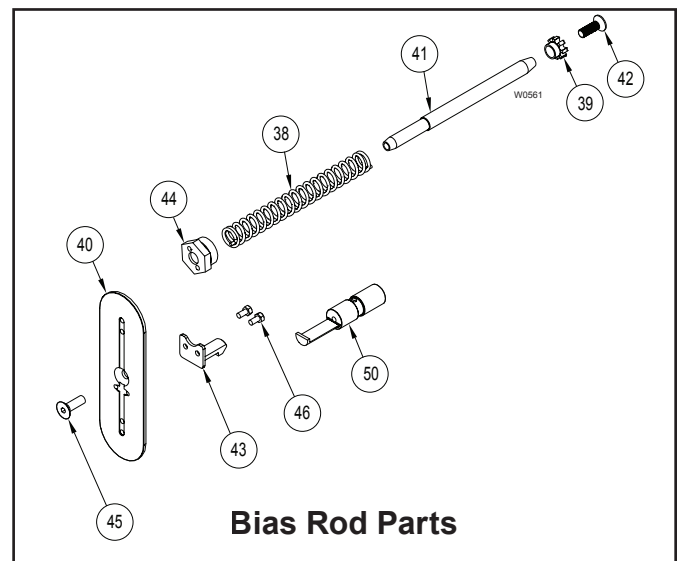

- See *Bias Rod Parts and Diaphragm Parts Views*. Remove diaphragm parts as in steps a. through d. above.
- Remove screw (45) and diaphragm clamp (40) with valve arm (43) and two attaching screws (46).
- Remove valve spool (50) from diaphragm plate (32).
- Check diaphragm clamp for any rough surfaces, edges, or corrosion. Replace if necessary.
- Unscrew bias tube cap (44).
- Remove bias rod parts: bias spring (38), bias rod (41), spring guide (39), and screw (42).
- Inspect rod parts. Smooth surfaces and edges as necessary with emery cloth or fine file. Replace parts as necessary.

# T100 Low Hydraulic Section Service (Cont'd)

---

## Hydraulic Section Disassembly (Cont'd)

### Diaphragm Plate Disassembly

 **WARNING: Manifold (56) and assembled parts weigh over 200 pounds (91 kg) and are a two man lift. Use care in handling to prevent personal injury or damage to equipment.**

- a. Slide manifold (56) away from diaphragm plate (32), following steps a. through d. in the Remove Manifold Assembly Section.

 **WARNING: Diaphragm plate (32) and assembled parts weigh over 100 pounds (45 kg) and are a two man lift. Use care in handling to prevent personal injury or damage to equipment.**

**Note: To ease handling of diaphragm plate, install two Eyebolts (177-058) from T100 Low Pressure Tool Kit in place of two Setscrews (55) on top of diaphragm plate.**

- b. See *Hydraulic Section Parts view*. Remove two cap screws (52) from diaphragm plate (32).
- c. Carefully slide diaphragm plate and assembled parts away from pump along pump studs.
- d. Replace diaphragm plate gasket (24) if damaged.

### Check/Replace Airbleed Valve

- a. See *Valve Parts View*. Unthread airbleed valve (35) from diaphragm plate (32). Inspect valve and replace if needed.
- b. Reinstall airbleed valve. Torque to 75 ft-lbs (102 N-m).

### Check/Replace Underfill Valve

- a. See *Valve Parts View*. Unthread underfill valve (33) from bottom of diaphragm plate (32). Inspect valve and replace if needed.
- b. Reinstall underfill valve. Torque to 30 ft-lbs (41 N-m).

### Check/Replace Overfill Valve Assembly

- a. See *Valve Parts View*. Unthread overfill valve (34) from bottom of diaphragm plate (32). Inspect overfill valve and replace if needed.
- b. Reinstall overfill valve. Torque to 105 in-lbs (12 N-m).

# T100 Low Hydraulic Section Service (Cont'd)

---

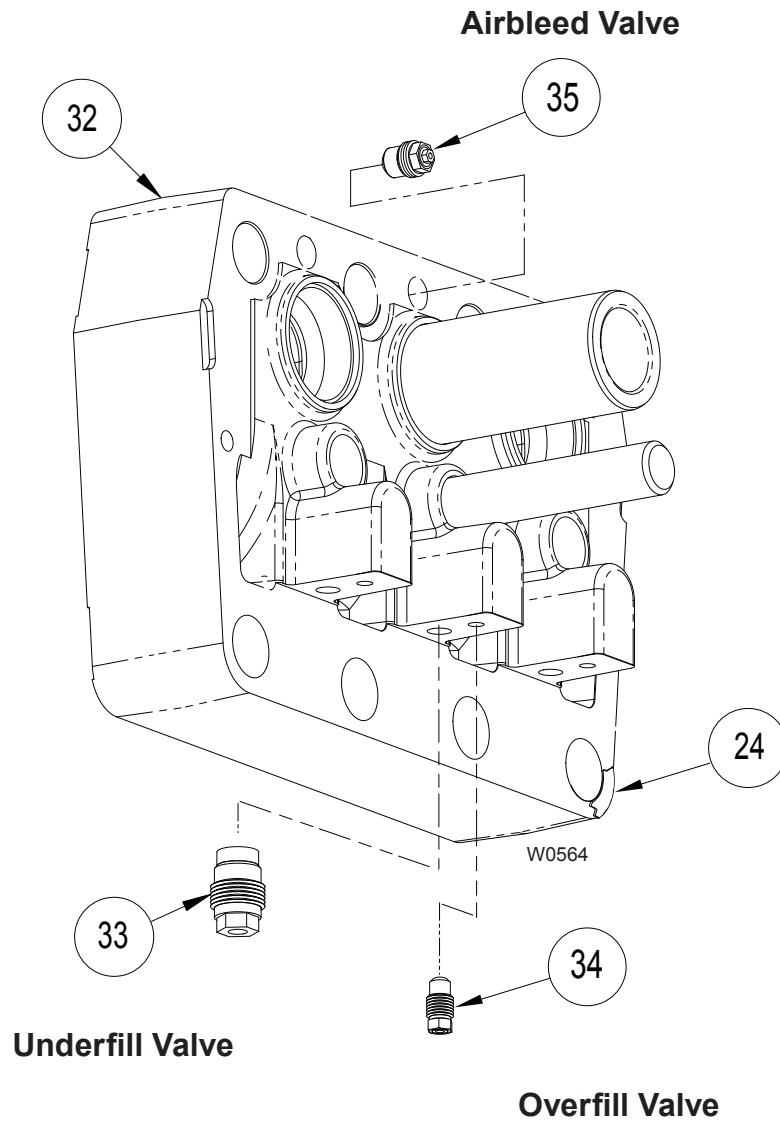

**Valve Parts View**



# T100 Low Hydraulic Section Service (Cont'd)

## Hydraulic Section Assembly

### Diaphragm Plate Assembly

 **WARNING:** Diaphragm plate (32) and assembled parts weigh over 100 pounds (45 kg) and are a two man lift. Use care in handling to prevent personal injury or damage to equipment.

**Note:** To ease handling of diaphragm plate, install two Eyebolts (177-058) from T100 Tool Kit in place of two Setscrews (55) on top of diaphragm plate.

- a. Replace diaphragm plate gasket (24) if damaged.

**CAUTION:** Ensure plungers (54) are lubricated with oil before assembly. Dry plungers and cylinders can bind on start-up.

- b. See *Hydraulic Section Parts Illustration*. Carefully slide diaphragm plate (32) and assembled parts along pump studs flush with Power End of pump.
- c. Screw two cap screws (52) into diaphragm plate. Torque to 50 ft-lbs (68 N-m).
- d. Hand rotate to assure smooth operation.

### Bias Rod Assembly

**CAUTION:** It is important to observe the following steps a. and b. to insure proper assembly.

- a. See *Bias Rod Parts View*. Clean threads of screw (42). Make sure threads are dry and oil free. Prime threads with Loctite Primer N.
- b. Apply No. 242 Loctite to screw and insert through spring guide (39) and thread into bias rod (41).
- c. Install bias rod assembly parts into diaphragm plate (32). Thread bias tube cap (44) into bias tube with: bias spring (38), bias rod, spring guide, and screw. Make sure spring tangs mate with spring guide and bias tube cap. Use Loctite 242 on bias tube cap and torque to 50 ft-lbs (68 N-m).
- d. Insert valve spool (50) into diaphragm plate (32).
- e. Thread screw (45) through diaphragm clamp (40) with valve arm (43) and two attaching screws (46) into bias rod. Use Loctite 242 on screw (45) and torque to 20 ft-lbs (27 N-m).

**CAUTION:** Use care not to over-tighten as that can cause the rod to rotate and bind the bias spring. Verify the bias spring is not bound by pulling the diaphragm clamp out and verifying that the clamp has full range of motion.

- f. Repeat for three rod assemblies.

## Diaphragm Assembly

- a. See *Diaphragm Parts View*.

**CAUTION:** It is important to observe the following steps d. and e. to ensure proper assembly.

- b. Install the diaphragm (47) into diaphragm plate (32). Seat diaphragm edge with fingers. Make sure diaphragm bead is fully seated into the square groove of diaphragm plate.
- c. Install back-up ring (51) between diaphragm plate and diaphragm.
- d. Install two O-rings (49) into follower (48).
- e. Attach follower to diaphragm clamp with two screws (53). Use Loctite 242 and torque to 60 in-lbs (7 N-m).
- f. Repeat steps a. through e. for three diaphragms.

 **WARNING:** Manifold (56) and assembled parts weigh over 200 pounds (91 kg) and are a two man lift. Use care in handling to prevent personal injury or damage to equipment.

## Manifold Assembly

- a. See *Fluid End Parts View*. Prior to manifold assembly, inspect mating surfaces of pump and manifold. Make sure they are clean and free of any foreign material. Ensure diaphragm beads are seated.
- b. Carefully slide manifold (56) onto pump studs. If used, remove four 177-393 Extender Studs from pump and install eight bolts (73) around inlet retainer plate (71) and hand tighten.

**CAUTION:** The manifold should slide cleanly onto the pump and the back-up rings should be engaged into the mating grooves in the manifold prior to tightening. Failure to slide the manifold all the way on engaging the back-up rings prior to tightening can cause the back-up ring to be pinched and cause the pump to leak. If the manifold does not slide easily onto the pump, use scotch-brite or fine abrasive paper to clean the outer edge of the groove where the back-up ring fits.

- c. Thread on eight hex nuts (26) and hand tighten.
- d. Tighten hex nuts in torque sequence shown below to 450 ft-lbs (610 N-m).
- e. Thread on eight bolts (73) and hand tighten.
- f. Tighten bolts in torque sequence shown below to 300 ft-lbs (407 N-m).

# T100 Low Hydraulic Section Service (Cont'd)

## Hydraulic Section Assembly (Cont'd)

- g. Fill pump with oil to mark on dipstick (Approximately 18 qts (17 liters)).
- h. Follow instructions in Before Initial Start-Up and Initial Start-Up Section to start pump.

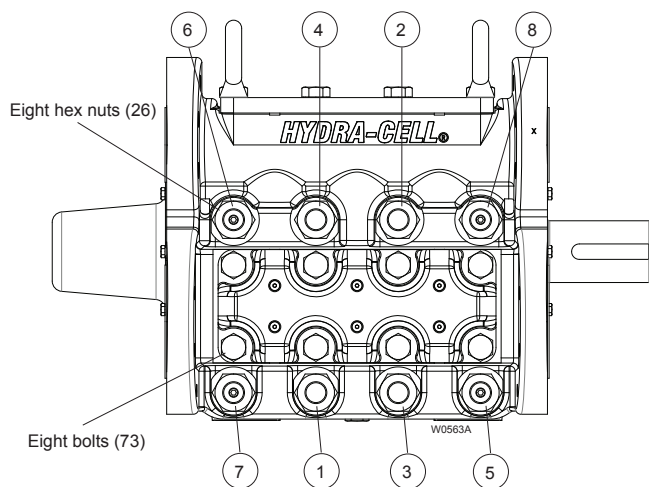

### Torque sequence:

- Snug eight hex nuts (26) in order indicated, then torque to 450 ft-lbs (610 N-m) in order indicated.
- Repeat same snug and torque sequence for corresponding bolts (73) to 300 ft-lbs (407 N-m).

# T100 Series Low Pressure Power End Service

**WARNING:** Crankcase (2) and assembled parts weigh over 100 pounds (45 kg) and are a two man lift. Use care in handling to prevent personal injury or damage to equipment.

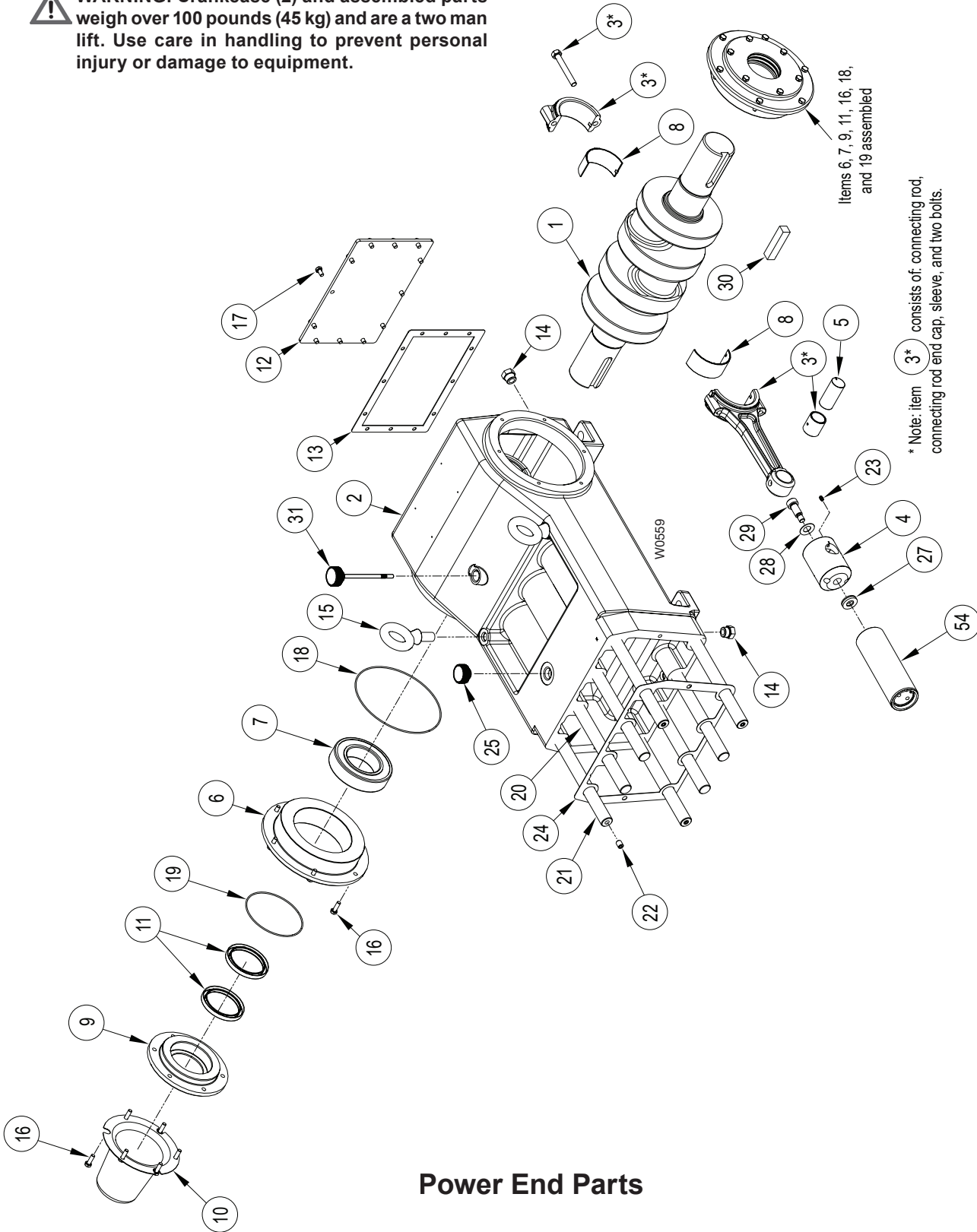

## Power End Parts

# T100 Series Low Power End Service (Cont'd)

## Power End Disassembly

 **WARNING:** Crankcase (2) and assembled parts weigh over 100 pounds (45 kg) and are a two man lift. Use care in handling to prevent personal injury or damage to equipment.

## Crankcase Disassembly

**Note:** The numbers in parentheses are the Reference Numbers shown in the Power End Parts View in this section of the manual and in the Parts Section of the manual.

- Remove Fluid End and Hydraulic plate as outlined in two preceding sections.
- See *Power End Parts Illustration*. Remove two drain plugs (14), cap with o-ring (25), dipstick (31), and crankshaft key (30) and drain lubricating fluid into a suitable container.
- Remove 12 cap screws (17) and remove back cover (12) and back cover gasket (13).

## Connecting Rod Removal

**Note:** Each of three Connecting rod assemblies (3\*) consists of: connecting rod, connecting rod end cap, sleeve, and two bolts.

- Remove connecting rod assembly bolts (3\*) and remove connecting rod end cap (3\*) with split shell bearing. Make sure numbers on connecting rod and end cap are 'top-up' in the assembly and match.

**Note:** Make sure to note 'top-up' orientation of numbers on connecting rod and end cap when removing. These are matched parts and must be stored together as one assembly and not mixed with any other connecting rod assemblies or parts.

- Set aside connecting rod assembly bolts, end cap, and one half split shell bearing (8) for use in reassembly.
- Remove connecting rod assembly from crankshaft by reaching into rear of crankcase (2) around crankshaft (1). Push connecting rod assembly away from journal on the crankshaft. Move as far forward as possible.
- Repeat removal for three sets.

## Crankshaft Removal

- Remove six cap screws (16) from one side of pump attaching seal and bearing assembly (assembled items 6, 7, 9, 11, 16, 18, and 19) to the crankcase (2).
- Carefully remove crankshaft (1) with seal and bearing assembly from crankcase.
- Remove seal and bearing assembly from end of crankshaft.
- Remove six screws (16) and remaining seal and bearing assembly from crankcase.

## Seal and Bearing Disassembly

- Separate seal and bearing assemblies by removing six cap screws (16).
- Remove O-ring (18) from bearing cover (6). Remove roller bearing (7) from bearing cover.
- Remove O-ring (19) from seal cover (9). Remove two crankshaft seals (11) from seal cover.
- Disassemble two sets.

## Connecting Rod Disassembly

**Note:** Make sure to note 'top-up' orientation of numbers on connecting rod and end cap when storing. These are matched parts and must not be mixed with parts from other connecting rod assemblies.

- Pull out connecting rod/plunger assembly and remove from crankcase.
- Remove remaining one half of split shell bearing (8) from connecting rod (3\*). Match with shell bearing already removed in **Connecting Rod Removal**.
- Retrieve bolts (3\*), and end cap (3\*) from previous step in **Connecting Rod Removal**. Be careful not to mix with parts from other connecting rod assemblies.
- Loosely assemble two bolts, and connecting rod end cap with connecting rod assembly and set aside. Note proper orientation of numbers on connecting rod and end cap.
- Remove setscrew (23) to unlock wrist pin (5). Remove wrist pin, assembled plunger and slider from connecting rod. Note alignment marks on wrist pin and alignment mark on crosshead (4).
- Disassemble and remove three sets.

## Plunger Disassembly

- Remove shoulder screw (29) from plunger assembly to remove plunger (54), spherical washer (27), slider (4), and Belleville spring (28).
- Disassemble three sets as in step a.
- Clean crankcase for later reassembly.

# T100 Series Low Power End Service (Cont'd)

## Power End Assembly

 **WARNING:** Crankcase (2) and assembled parts weigh over 100 pounds (45 kg) and are a two man lift. Use care in handling to prevent personal injury or damage to equipment.

## Plunger Assembly

**Note:** The numbers in parentheses are the Reference Numbers shown in the Power End Parts Illustration.

- Start with crankcase (2) clean and ready to assemble.
- Assemble plunger (54), spherical washer (27), slider (4), belleville spring (28), with shoulder screw (29). Use Loctite 242 and torque to 50 ft-lbs (68 N-m).

**Note:** One concave side of spherical washer assembly (27) mates with plunger (54) and the other convex side of spherical washer assembly mates with slider (4).

- Assemble three sets.

## Connecting Rod Assembly

**Note:** Each of three Connecting rod assemblies (3\*) consists of: connecting rod, connecting rod end cap, sleeve, and two bolts.

- Attach assembled plunger and slider to connecting rod (3\*) using wrist pin (5). Align marks on wrist pin with marks on slider (4). Lock wrist pin in place with setscrew (23). Use Loctite 271 and torque to 60 in-lbs (7 N-m).

**Note:** Make sure to note 'top-up' orientation of numbers on connecting rod and end cap when taking apart. These are matched parts and must not be mixed with parts from other connecting rod assemblies.

- Remove two bolts (3\*) and connecting rod end cap (3\*) from connecting rod assembly. Note orientation numbers on connecting rod and end cap.
- Set aside bolts and end cap for later installation. Do not mix with parts from other connecting rod assemblies.
- Install one half of split shell bearing (8) on connecting rod. Remaining one half of split shell bearing will be installed later.
- Insert connecting rod/plunger assembly into crankcase and push all the way forward. Ensure numbers are "top-up."
- Assemble and install three sets.

## Seal and Bearing Assembly

- Press two crankshaft seals (11) into seal cover (9). Install O-ring (19) onto seal cover.
- Install roller bearing (7) into bearing cover (6). Install O-ring (18) onto bearing cover.
- Bolt seal and bearing assemblies together using six cap screws (16).
- Assemble two sets.

## Crankshaft Installation

- Install one seal and bearing assembly to either side of crankcase (2) using six screws (16). Crankshaft (1) will be installed on opposite side.
- Place remaining seal and bearing assembly on following end of crankshaft.

**Note:** No shimming of crankshaft is necessary. End play of crankshaft should be between 0.010 in. minimum to 0.200 in. maximum when installed.

- Insert crankshaft with seal and bearing assembly into crankcase and insert into installed seal and bearing assembly on opposite end of crankcase. Align flange of seal and bearing assembly with flange on crankcase.
- Bolt flange of seal and bearing assembly to crankcase with six cap screws (16).

## Connecting Rod Installation

**Note:** Each of three Connecting rod assemblies (3\*) consists of: connecting rod, connecting rod end cap, sleeve, and two bolts.

- Attach connecting rod assembly to crankshaft (1) by reaching into rear of crankcase around crankshaft and pulling connecting rod assembly until it reaches its journal on the crankshaft.

**Note:** Make sure to note 'top-up' orientation of numbers on connecting rod and end cap when installing. These are matched parts and must not be taken from other connecting rod assemblies.

- Retrieve connecting rod assembly bolts, end cap, and remaining split shell bearing (8) set aside in previous steps.
- Reinstall connecting rod end cap with remaining split shell bearing using connecting rod assembly bolts. Make sure numbers on connecting rod and end cap are 'top-up' in the assembly and match. Torque two bolts to 100 ft-lbs (136 N-m).
- Repeat installation for three sets.

## Crankcase Assembly

**Note:** for torque values refer to the table following the Parts List Section.

- Install back cover (12) and back cover gasket (13) using 12 cap screws (17).
- Install crankshaft cover (10) on crankshaft end not used with six cap screws (16) used to attach seal and bearing assembly.
- If removed, reinstall four studs (21), with four set screws (22), four studs (20), and two eyebolts (15).
- Install two plugs (14), cap with o-ring (25), dipstick (31), and crankshaft key (30) and add lubricating fluid.

# T100 Series Low Pressure Troubleshooting

---

## Cavitation

- Inadequate fluid supply because:
  - Inlet line collapsed or clogged
  - Clogged line strainer
  - Inlet line too small or too long
  - Air leak in inlet line
  - Worn or damaged inlet hose
  - Suction line too long
  - Too many valves and elbows in inlet line
- Fluid too hot for inlet suction piping system
- Air entrained in fluid piping system
- Aeration and turbulence in supply tank
- Inlet vacuum too high (refer to “Inlet Calculations” paragraph)

## Symptoms of Cavitation

- Excessive pump valve noise
- Premature failure of spring or retainer
- Volume or pressure drop
- Rough-running pump
- Premature failure

## Drop in Volume or Pressure

A drop in volume or pressure can be caused by one or more of the following:

- Air leak in suction piping
- Clogged suction line or suction strainer
- Suction line inlet above fluid level in tank
- Inadequate fluid supply
- Pump not operating at proper Rpm
- Relief valve bypassing fluid
- Worn pump valve parts
- Foreign material in inlet or outlet valves
- Loss of oil prime in cells because of low oil level
- Ruptured diaphragm
- Cavitation
- Warped manifold from overpressurized system
- O-rings forced out of their grooves from overpressurization
- Air leak in suction line strainer or gasket
- Cracked suction hose
- Empty supply tank
- Excessive aeration and turbulence in supply tank
- Worn and slipping drive belt(s)
- Worn spray nozzle(s)
- Cracked cylinder

## Pump Runs Rough

- Worn pump valves
- Air lock in outlet system
- Oil level low
- Wrong viscosity of oil for cold operating temperatures (change to lighter weight)
- Cavitation
- Air in suction line
- Restriction in inlet/suction line
- Hydraulic cells not primed after changing diaphragm
- Foreign material in inlet or outlet valve
- Damaged diaphragm
- Fatigued or broken valve spring

## Premature Failure of Diaphragm

- Frozen pump
- Puncture by a foreign object
- Elastomer incompatible with fluid being pumped
- Pump running too fast
- Excess pressure
- Cavitation
- Aeration or turbulence in supply tank

## Valve Wear

- Normal wear from high-speed operation
- Cavitation
- Abrasives in the fluid
- Valve incompatible with corrosives in the fluid
- Pump running too fast

## Loss of Oil

- External seepage
- Rupture of diaphragm
- Frozen pump
- Worn shaft seal
- Oil drain plug or fill cap loose
- Valve plate and manifold bolts loose

## Premature Failure of Valve Spring or Retainer

- Cavitation
- Foreign object in the pump
- Pump running too fast
- Spring/retainer material incompatible with fluid being pumped
- Excessive inlet pressure



# T100 Series Low Torque Specifications

## Torque Specification Table for the T100E

T100E Torque Specification Table				
Reference Number	Torque Specification (N-m)	Loctite No.	Part Number	Description
3	100 ft-lbs (136)		177-003-02	Bolts, Connecting Rod Assembly
15	300 ft-lbs (407)		177-059	Eyebolt, M20
16	12 ft-lbs (16)	242	177-048	Screw, Cap, hex-hd, M8, 25 mm
17	12 ft-lbs (16)	242	177-043	Screw, Cap, hex-hd, M8, 15 mm
20	*	242	177-150	Stud, 27 mm x 300 mm
21	*	242	177-151	Stud, 27 mm x 300 mm, c-bore 12 mm
23	60 in-lbs (7)	271	G10-082-2010	Setscrew, M6, 10 mm
26	450 ft-lbs (610)		177-152	Nut, Hex, M27
29	50 ft-lbs (68)	242	177-047	Screw, Shoulder, M16, 30 mm
33	30 ft-lbs (41)		177-904	Cartridge, Underfill valve
34	105 in-lbs (12)		177-905	Cartridge, Overfill valve
35	75 ft-lbs (102)	242	177-906	Cartridge, Air Bleed valve
36	100 ft-lbs (136)	242	177-329	Cylinder, E
42	20 ft-lbs (27)	271	177-149	Screw, M8, 25 mm, OHMS
44	50 ft-lbs (68)	242	177-358	Cap, Bias tube
45	20 ft-lbs (27)	242	177-359	Screw, Flat-hd, M8, 25 mm
46	75 in-lbs (8)	242	177-050	Screw, Cap, hex-hd, M5, 10 mm
52	50 ft-lbs (68)		G10-024-2010	Screw, Cap, soc-hd, M10, 90 mm
53	60 in-lbs (7)	242	177-176	Screw, Flat-hd, M6 x 1.0 x 16 mm
72	75 in-lbs (8)		177-052	Screw, Shoulder, M8, 12 mm
73	300 ft-lbs (407)		177-044	Screw, Cap, hex-hd, M20, 50 mm
74	40 ft-lbs (54)	**	177-014-01	Plug, Drain
75	*	**	D10-047-2110 D10-047-2111	O-ring, Buna-N O-ring, FKM

\* No torque requirement, Loctite only.

\*\* Apply Loctite nickel anti-sieze lubricant to threads and chamfer of item 74, with coverage on item 75.



# T100 Series Low Pressure Fluid End Parts

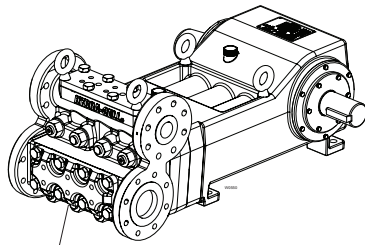

Fluid End

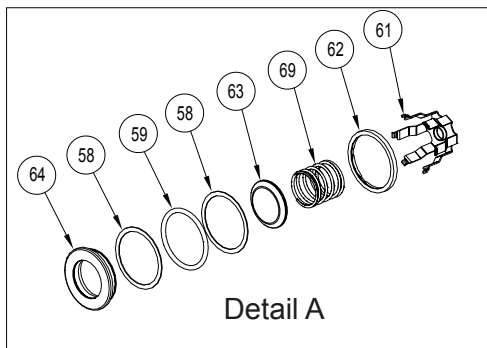

Detail A

Inlet Valve  
See Detail A

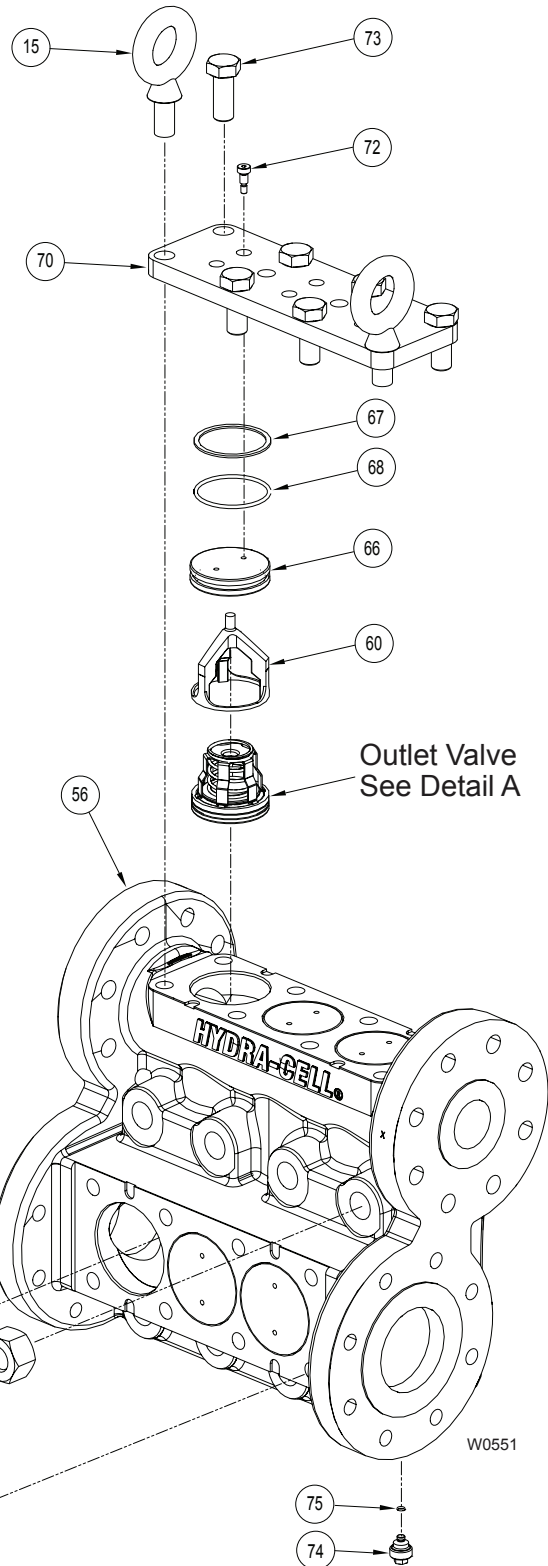
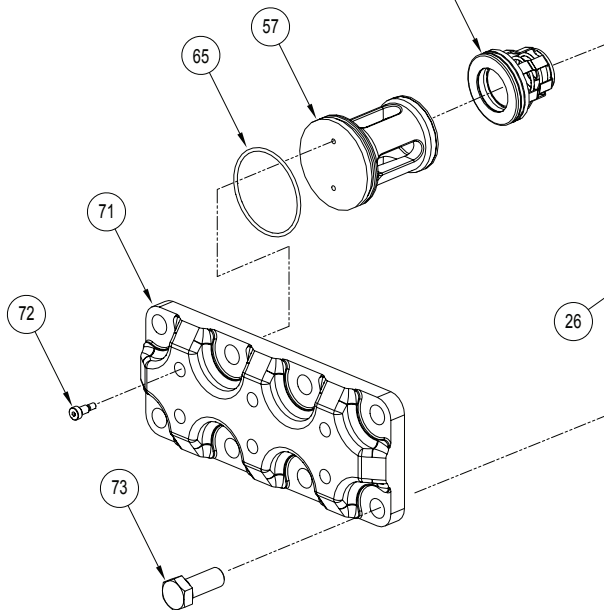

Note: for torque values refer to the table following the Troubleshooting Section

# T100 Series Low Fluid End Parts (Cont'd)

Ref. No.	Part Number	Description	Quantity/ Pump
15	177-059	Eyebolt, M20 .....	2
26	177-152	Nut, Hex, M27 .....	8
56	177-300-103	Manifold, NAB .....	1
	177-300-104	Manifold, SST .....	1
57	177-314-03	Support Plug, Inlet valve .....	3
58	177-384-03	Ring, Back-up, PVDF .....	12
59	177-385-01	O-ring, Buna-N .....	6
	177-385-02	O-ring, FKM .....	6
60	177-346-03	Retainer, Outlet, 316 SST .....	3
61	177-306-04	Retainer, Valve spring, 17-7 SST .....	6
62	177-313-01	Ring, Lock, 17-7 SST .....	6
63	177-308-01	Valve Disc, 17-4 SST .....	6
64	177-302-01	Valve Seat, 17-4 SST .....	6
65	177-383-01	O-ring, Buna-N .....	3
	177-383-02	O-ring, FKM .....	3
66	177-348-01	Plug, Outlet valve port, 316 SST .....	3
67	177-381-01	Ring, Backup, Buna-N .....	3
	177-381-02	Ring, Backup, FKM .....	3
68	177-382-01	O-ring, Buna-N .....	3
	177-382-02	O-ring, FKM .....	3
69	177-309-01	Spring, Elgiloy .....	6
70	177-310	Plate, Retainer, discharge CV .....	1
71	177-121-02	Plate, Retainer, inlet .....	1
72	177-052	Screw, Shoulder, M8, 12 mm .....	12
73	177-044	Screw, Cap, hex-hd, M20, 50 mm .....	14
74	177-014-01	Plug, Drain .....	3
75	D10-047-2110	O-ring, Buna-N .....	3
	D10-047-2111	O-ring, FKM .....	3

# T100 Series Low Hydraulic Section Parts

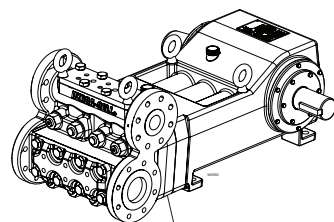

Hydraulic Section

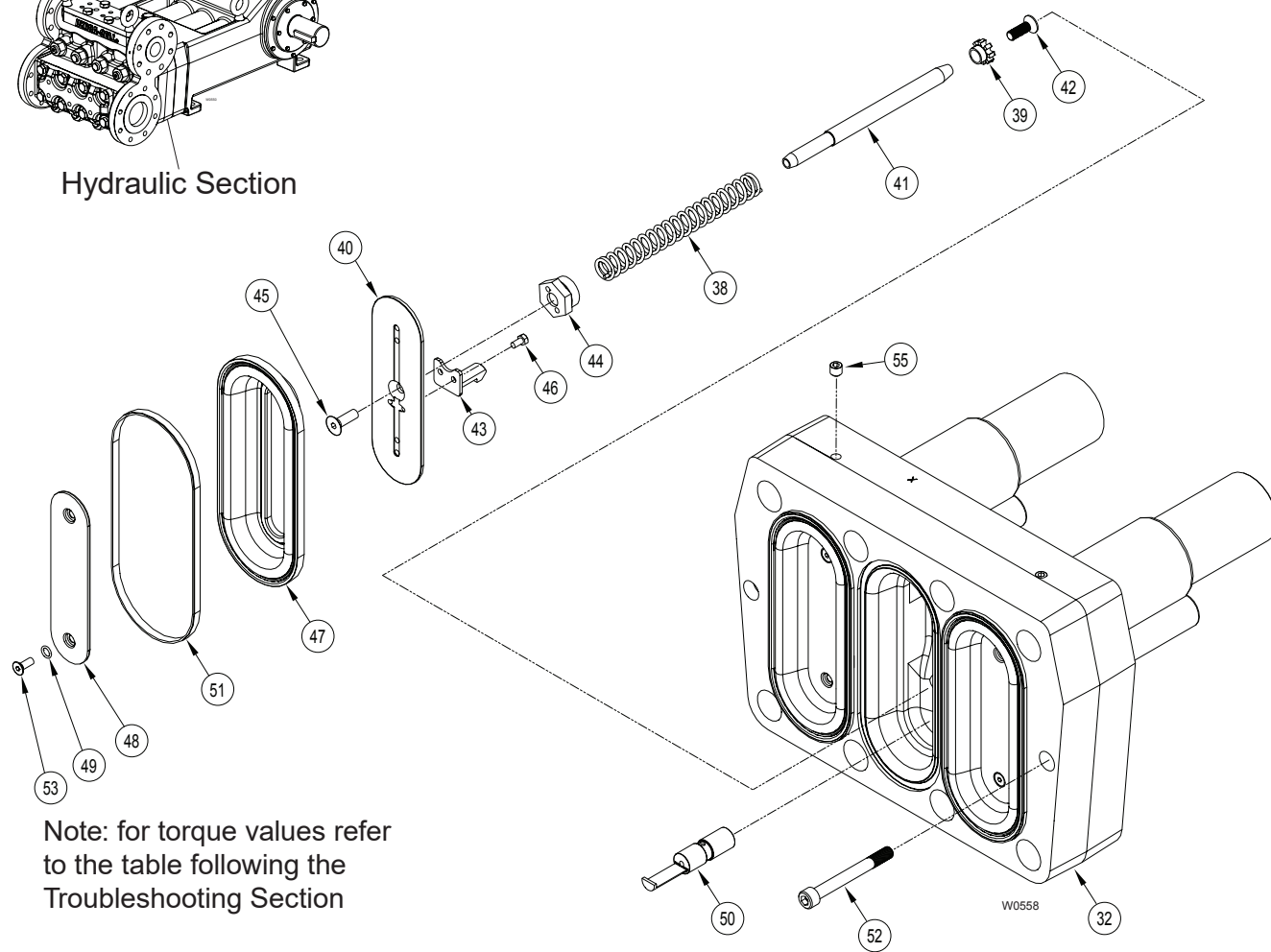

Note: for torque values refer to the table following the Troubleshooting Section

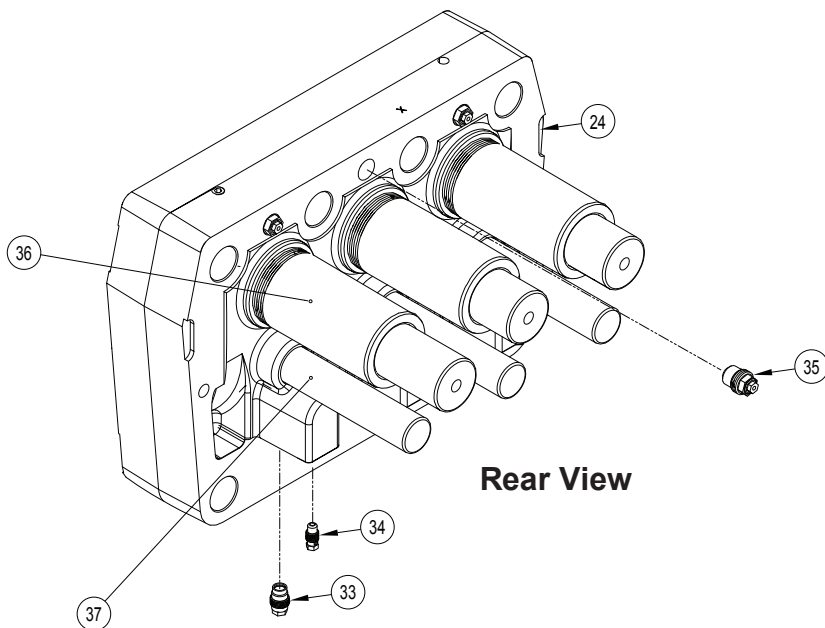

Rear View

# T100 Low Hydraulic Section Parts (Cont'd)

Ref. No.	Part Number	Description	Quantity/ Pump
24	177-013	Gasket, Diaphragm plate .....	1
32	177-301-02	Diaphragm Plate .....	1
33	177-904	Cartridge, Underfill valve .....	3
34	177-905	Cartridge, Overfill valve .....	3
35	177-906	Cartridge, Air Bleed valve .....	3
36	177-329	Cylinder, E .....	3
37	177-356	Tube, Valve .....	3
38	177-332	Spring, Bias .....	3
39	177-312	Guide, Spring .....	3
40	177-352	Clamp, Diaphragm .....	3
41	177-355	Rod, Bias spring .....	3
42	177-149	Screw, M8, 25 mm, OHMS .....	3
43	177-351	Arm, Valve .....	3
44	177-358	Retainer, Bias spring .....	3
45	177-359	Screw, Flat-hd, M6-6g x 25 mm .....	3
46	177-050	Screw, Cap, hex-hd .....	6
47	177-375-01	Diaphragm, Buna-N .....	3
	177-375-02	Diaphragm, FKM .....	3
48	177-376-01	Diaphragm Follower, 316/316L, SST ..	3
49	100-217-01	O-ring, Buna-N .....	6
	100-217-02	O-ring, FKM .....	6
50	177-009	Spool, Valve .....	3
51	177-338	Ring, Diaphragm, back-up .....	3
52	G10-024-2010	Screw, Cap, soc-hd, M10, 90 mm .....	2
53	177-176	Screw, Flat-hd, M6 x 1.0 x 16 mm .....	6
55	177-117	Setscrew, M10, 10 mm .....	2

# T100 Series Low Pressure Power End Parts

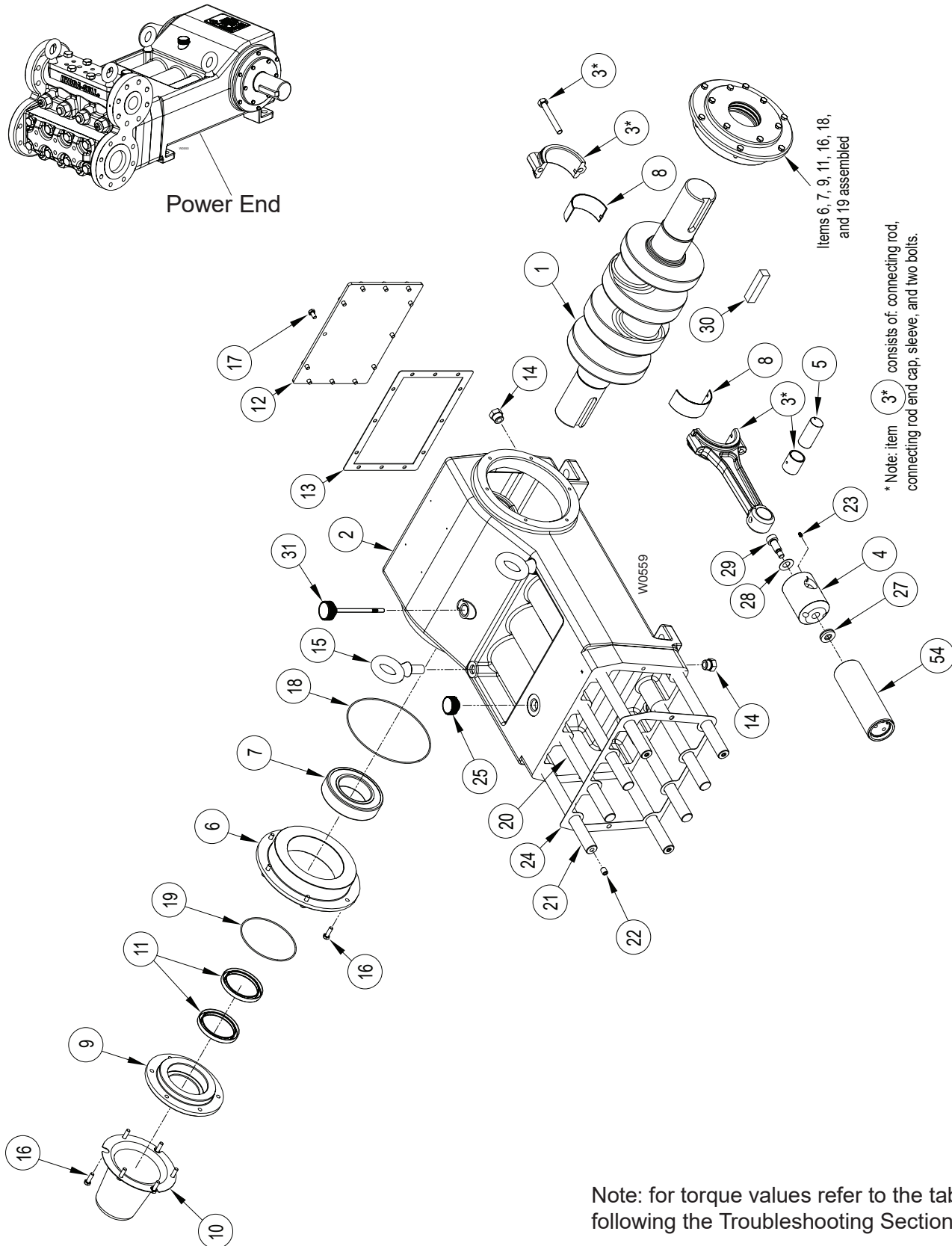

Note: for torque values refer to the table following the Troubleshooting Section

# T100 Series Low Power End Parts (Cont'd)

Ref. No.	Part Number	Description	Quantity/ Pump
1	177-002-06	Crankshaft, Forged .....	1
2	177-001-02	Crankcase .....	1
3	177-003-02	Connecting Rod Assembly.....	3
4	177-005	Slider .....	3
5	177-032	Pin, Wrist.....	3
6	177-021	Cover, Bearing .....	2
7	177-027	Bearing, Roller, spherical.....	2
8	177-041	Bearing, Split shell (pair).....	3
9	177-034	Cover, Seal.....	2
10	177-035	Cover, Crankshaft .....	1
11	177-028	Seal, Crankshaft.....	4
12	177-022	Cover, Back .....	1
13	177-026	Gasket, Back cover .....	1
14	177-038	Plug, SAE, 7/8-14 .....	2
15	177-059	Eyebolt, M20 .....	2
16	177-048	Screw, Cap, hex-hd, M8, 25 mm.....	24
17	177-043	Screw, Cap, hex-hd, M8, 15 mm.....	12
18	H25-037-2110	O-ring, Buna-N.....	2
19	D10-109-2110	O-ring, Buna-N.....	2
20	177-150	Stud, 27 mm x 300 mm .....	4
21	177-151	Stud, 27 mm x 300 mm, c-bore 12 mm ..	4
22	177-118	Setscrew, M12, 15 mm .....	4
23	G10-082-2010	Setscrew, M6, 10 mm.....	3
24	177-013	Gasket, Diaphragm plate .....	Ref
25	D03-039-1030	Cap, Oil fill (with o-ring).....	1
27	177-031	Washer, Spherical .....	3
28	177-030	Spring, Belleville.....	3
29	177-047	Screw, Shoulder, M16, 30 mm .....	3
30	177-036	Key, Crankshaft .....	1
31	177-912	Dipstick.....	1
54	177-324	Assembly, Plunger, E .....	3

# T100 Series Low Pressure Tool Kit Parts

## T100 Low Pressure Tool Kit

The T100 Low Pressure Tool Kit (Part No. 177-811) contains the tools illustrated below. These tools are used to assist in the repair and maintenance of the T100E. See the maintenance sections of this manual for specific application.

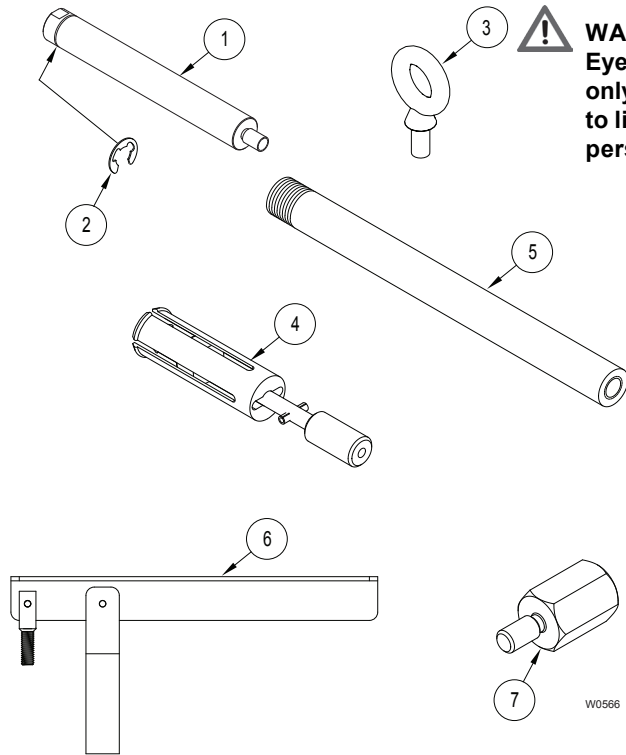

**! WARNING: Item 3, M10 Diaphragm Plate Eyebolt is used to lift Diaphragm Plate (32) only. Do not use to lift entire pump. Attempting to lift entire pump with Eyebolt (3) may cause personal injury or damage to equipment.**

Ref. No.	Tool Part No.	Tool Description	Quantity/Kit
1	177-393	Stud Extender .....	4
2	177-392	Clip, E-style .....	4
3	177-058	Diaphragm Plate Eyebolt, M10.....	2
4	177-918	Inlet Check Valve Extractor .....	1
5	177-140	Outlet Check Valve Extractor, Flange .....	1
6	A03-124-1200	Check Valve Extractor Lever .....	1
7	177-157	Thread Adapter, Check Valve Extractor to Slide Hammer .....	1



# T100 Series Low Pressure Pump Storage

## Pump Storage for T100 Low Pressure

**CAUTION:** If the pump is to be stored more than six months take the following steps to protect against corrosion:

### After Shut Down of the pump:

1. Drain all process fluid from pump. Do not drain oil from the pump.

**CAUTION - Do not store the pump without oil in the reservoir.**

2. Flush the fluid end of the pump with a corrosion inhibitor that is compatible with the diaphragm material and process fluid.
3. Coat camshaft or crankshaft with rust preventative; wrap with wax-impregnated cloth and then with waterproof tape.
4. Plug the suction and discharge ports of the pump to protect against dirt and moisture.
5. Store in a clean, dry place.

### Prior to Start-up of the pump:

1. Drain and refill the hydraulic end of the pump with the appropriate Hydra-Oil.

# T100 Series Low Replacement Parts Kits

## T100 Low Pressure Bias Rod Assembly Kit Contents (Part No. 177-804)

Part Number	Description	Quantity
177-149	Screw, M8	1
177-312	Guide, Spring	1
177-355	Rod, Bias spring	1
177-332	Spring, Bias	1
177-050	Screw, M5	2
177-351	Arm, Valve	1
177-352	Clamp, Diaphragm	1
177-359	Screw, M8	1

## T100 Low Pressure Hydraulic End Kit Contents (Part No. 177-810)

Part Number	Description	Quantity
177-804	Bias Rod Assembly	3
177-906	Valve, Air Bleed	3
177-904	Valve, Underfill	3
177-905	Valve, Overfill	3
177-009	Valve, Spool	3
177-013	Gasket, Diaphragm plate	1

# T100 Low Replacement Parts Kits - Cont'd

TO ORDER REPLACEMENT PARTS KIT: A Replacement Parts Kit contains 11 digits corresponding to customer-specified design options.

1	2	3	4	5	6	7	8	9	10	11	12
---	---	---	---	---	---	---	---	---	----	----	----

Digit	Order Code	Description
1-4		<b>Pump Configuration</b>
	<b>T100</b>	For all T100 Series Pumps
5		<b>Performance</b>
	<b>L</b>	Low Pressure (T100E)
6		<b>Kit Designator</b>
	<b>D</b>	Diaphragm Kit
	<b>V</b>	Valve Kit
7		<b>Pump Head Material</b>
	<b>5</b>	Metallic Pump Head Version
8		<b>Diaphragm &amp; O-ring Material</b>
	<b>G</b>	FKM
	<b>T</b>	Buna-N
9		<b>Valve Seat Material</b>
	<b>H</b>	17-4 PH Stainless Steel
	<b>T</b>	Hastelloy C
	<b>X</b>	Not included in Diaphragm Kit
10		<b>Valve Material</b>
	<b>H</b>	17-4 PH Stainless Steel
	<b>T</b>	Hastelloy C
	<b>X</b>	Not included in Diaphragm Kit
11		<b>Valve Springs</b>
	<b>E</b>	Elgiloy
	<b>X</b>	Not included in Diaphragm Kit
12		<b>Valve Spring Retainers</b>
	<b>H</b>	17-7 Stainless Steel
	<b>X</b>	Not included in Diaphragm Kit

## T100 Low Pressure Kit D Contents

Part Number*	Description	Quantity
177-375-__	Diaphragm	3
177-338-__	Ring, Back-up	3
177-217-__	O-ring	6
177-176	Screw, M6	6

## T100 Low Pressure Kit V Contents

Part Number*	Description	Quantity
177-302-__	Valve Seat	6
177-384-03	Ring, Back-up, PVDF	12
177-385-__	O-ring	6
177-308-__	Valve Disc	6
177-309-01	Spring, Elgiloy	6
177-313-01	Ring, Lock	6
177-306-04	Retainer, 17-7 SST	6
177-381-__	Ring, Back-up	3
177-382-__	O-ring	3
177-383-__	O-ring	3

\* Last four digits of part numbers with -\_\_ refer to specific material of construction.

## **Limited Warranty**

Wanner Engineering, Inc. extends to the original purchaser of equipment manufactured by it and bearing its name, a limited one-year warranty from the date of purchase against defects in material or workmanship, provided that the equipment is installed and operated in accordance with the recommendations and instructions of Wanner Engineering, Inc. Wanner Engineering, Inc. will repair or replace, at its option, defective parts without charge if such parts are returned with transportation charges prepaid to Wanner Engineering, Inc., 1204 Chestnut Avenue, Minneapolis, Minnesota 55403.

This warranty does not cover:

1. The electric motors (if any), which are covered by the separate warranties of the manufacturers of these components.
2. Normal wear and/or damage caused by or related to abrasion, corrosion, abuse, negligence, accident, faulty installation or tampering in a manner which impairs normal operation.
3. Transportation costs.

This limited warranty is exclusive, and is in lieu of any other warranties (express or implied) including warranty of merchantability or warranty of fitness for a particular purpose and of any non contractual liabilities including product liabilities based on negligence or strict liability. Every form of liability for direct, special, incidental or consequential damages or loss is expressly excluded and denied.



**Wanner Engineering, Inc.**

**1204 Chestnut Avenue, Minneapolis, MN 55403**

**TEL: (612) 332-5681 FAX: (612) 332-6937**

**TOLL-FREE FAX [US only]: (800) 332-6812**

**www.hydra-cell.com**

**email: sales@wannereng.com**