

TLP Series

SANITARY POSITIVE DISPLACEMENT PUMP

FORM NO.: 95-03095-TLP_EN REVISION: 01/2013

READ AND UNDERSTAND THIS MANUAL PRIOR TO OPERATING OR SERVICING THIS PRODUCT.



SPX Flow Technology

www.spx.com

Information contained in this manual is subject to change without notice and does not represent a commitment on the part of SPX Corporation. No part of this manual may be reproduced or transmitted in any form or by any means, electronic or mechanical, including photocopying and recording, for any purpose, without the express written permission of SPX Corporation.

Copyright © 2009, 2013 SPX Corporation.
All Rights Reserved.

Gore-Tex is a registered trademark of W.L. Gore & Associates, Inc.
Kalrez is a registered trademark of DuPont Dow Elastomers.
Chemraz is a registered trademark of Greene, Tweed & Co

Revision Date: 01/2013

Publication: 95-03095-TLP_EN

Warranty	5
Shipping Damage or Loss	5
Warranty Claim	5
Safety	6
Replacement Labels	7
Application Instructions	7
Care of Stainless Steel	8
Stainless Steel Corrosion	8
Elastomer Seal Replacement Following Passivation	8
Introduction	9
Pump Model Designation	9
Intended Use	9
Pump Receiving	10
Pump Characteristics	10
Equipment Serial Number	10
Pump Shaft Location	10
Pump Dimensions	11
Mounting Dimensions	11
Technical Data	11
Sound Level	12
Maximum Particle Size	12
Installation	13
Install Pump and Drive Unit	13
Install Connections and Piping	14
Piping Support	14
Expansion Joints	14
Inlet Piping	14
Install Check Valves	15
Inlet Side on Lift Applications	15
Discharge Side	15
Install Isolation Valves	15
Install Relief Valves	15
Inlet Side Strainers and Traps	16
Install Pressure Gauges	16
Seal Flush Connections	16
CIP (Clean-In-Place) Guidelines	17
Check Coupling Alignment	17
Check Angular Alignment	17
Check Parallel Alignment	18
Check Belt and Chain Drive Alignment	18
Check Pump Rotation	19
Operation	20
Pre-Startup Checklist	20
Startup Procedure	20
Shutdown Procedure	20
Emergency Shutdown Procedure	20
Maintenance	21
Important Safety Information	21
Lubrication	21
Drive Lubrication	21
Gear Oil	21
Bearing Lubrication	22
Maintenance Inspections	22
Inspection of Shaft	22
Inspection of Hub End	22
Inspection of Shaft Shoulder	22
Inspection of Gears and Bearings	23

Recommended Maintenance Schedule	23
Maintenance Inspection Chart	24
Cleaning	24
Pump Disassembly - Hydraulic Components	25
Pump Cover Removal	25
Rotor Removal	25
Rotor Blocking	26
Pump Body Removal	26
Mechanical Seal Removal	27
Gearbox Disassembly	28
Gear Cover Removal	28
Gear and Shaft Removal	29
Bearing Removal	30
Pump Assembly	31
Install Front Seals	31
Bearing Assembly	31
Bearing Adjustment	32
Shaft Seal Installation	34
Mechanical seal guidelines/notes	35
Body Installation	35
Rotor Positioning	36
Rotor Installation	36
Setting Rotor Clearance	37
Gear Mounting and Rotor Synchronization	38
Verify Rotor Clearance	40
Gear Cover Installation	41
Cover Installation	42
Torque Reference	42
Troubleshooting	43
Parts Lists	48
Model 0040-0300 Pump Parts	48
Model 0670-3450 Pump Parts	52
Maintenance Kits	56

Warranty

Seller warrants its products to be free from defect in materials and workmanship for a period of one (1) year from the date of shipment. This warranty shall not apply to products which require repair or replacement due to normal wear and tear or to products which are subjected to accident, misuse or improper maintenance. This warranty extends only to the original Buyer. Products manufactured by others but furnished by Seller are exempted from this warranty and are limited to the original manufacturer's warranty.

Seller's sole obligation under this warranty shall be to repair or replace any products that Seller determines, in its discretion, to be defective. Seller reserves the right either to inspect the products in the field or to request their prepaid return to Seller. Seller shall not be responsible for any transportation charges, duty, taxes, freight, labor or other costs. The cost of removing and/or installing products which have been repaired or replaced shall be at Buyer's expense.

Seller expressly disclaims all other warranties, express or implied, including without limitation any warranty of merchantability of fitness for a particular purpose. The foregoing sets forth Seller's entire and exclusive liability, and Buyer's exclusive and sole remedy, for any claim of damages in connection with the sale of products. In no event shall Seller be liable for any special consequential incidental or indirect damages (including without limitation attorney's fees and expenses), nor shall Seller be liable for any loss of profit or material arising out of or relating to the sale or operation of the products based on contract, tort (including negligence), strict liability or otherwise.

Shipping Damage or Loss

If equipment is damaged or lost in transit, file a claim at once with the delivering carrier. The carrier has signed the Bill of Lading acknowledging that the shipment has been received from the seller in good condition. Seller is not responsible for the collection of claims or replacement of materials due to transit shortages or damages.

Warranty Claim

Warranty claims must have a **Returned Goods Authorization (RGA)** from the Seller before returns will be accepted.

Claims for shortages or other errors, exclusive of transit shortages or damages, must be made in writing to Seller within ten (10) days after delivery. Failure to give such notice shall constitute acceptance and waiver of all such claims by Buyer.

Safety

READ AND UNDERSTAND THIS MANUAL PRIOR TO INSTALLING, OPERATING OR SERVICING THIS EQUIPMENT

We recommend users of our equipment and designs follow the latest Industrial Safety Standards. At a minimum, these should include the industrial safety requirements established by:

1. Occupational Safety and Health Administration (OSHA), Title 29 of the CFR
Section 1910.212- General Requirements for all Machines
2. National Fire Protection Association, ANSI/NFPA 79
ANSI/NFPA 79- Electrical Standards for Industrial Machinery
3. National Electrical Code, ANSI/NFPA 70
ANSI/NFPA 70- National Electrical Code
ANSI/NFPA 70E- Electrical Safety Requirement for Employee Workplaces
4. American National Standards Institute, Section B11

Attention: Servicing energized industrial equipment can be hazardous. Severe injury or death can result from electrical shock, burn, or unintended actuation of controlled equipment. Recommended practice is to disconnect and lockout industrial equipment from power sources, and release stored energy, if present. Refer to the National Fire Protection Association Standard No. NFPA70E, Part II and (as applicable) OSHA rules for Control of Hazardous Energy Sources (Lockout-Tagout) and OSHA Electrical Safety Related Work Practices, including procedural requirements for:

- Lockout-tagout
- Personnel qualifications and training requirements
- When it is not feasible to de-energize and lockout-tagout electrical circuits and equipment before working on or near exposed circuit parts

Locking and Interlocking Devices: These devices should be checked for proper working condition and capability of performing their intended functions. Make replacements only with the original manufacturer's renewal parts or kits. Adjust or repair in accordance with the manufacturer's instructions.

Periodic Inspection: Industrial equipment should be inspected periodically. Inspection intervals should be based on environmental and operating conditions and adjusted as indicated by experience. At a minimum, an initial inspection within 3 to 4 months after installation is recommended. Inspection of the electrical control systems should meet the recommendations as specified in the National Electrical Manufacturers Association (NEMA) Standard No. ICS 1.3, Preventative Maintenance of Industrial Control and Systems Equipment, for the general guidelines for setting-up a periodic maintenance program.

Replacement Equipment: Use only replacement parts and devices recommended by the manufacturer to maintain the integrity of the equipment. Make sure the parts are properly matched to the equipment series, model, serial number, and revision level of the equipment.

Warnings and cautions are provided in this manual to help avoid serious injury and/or possible damage to equipment:



DANGER: marked with a stop sign.
Immediate hazards which WILL result in severe personal injury or death.



WARNING: marked with a warning triangle.
Hazards or unsafe practices which COULD result in severe personal injury or death.



CAUTION: marked with a warning triangle.
Hazards or unsafe practices which COULD result in minor personal injury or product or property damage.

Replacement Labels

! **WARNING:** The following labels are installed on your equipment. If these labels are removed or become unreadable, refer to "Parts Lists" on page 48 for replacement part numbers.

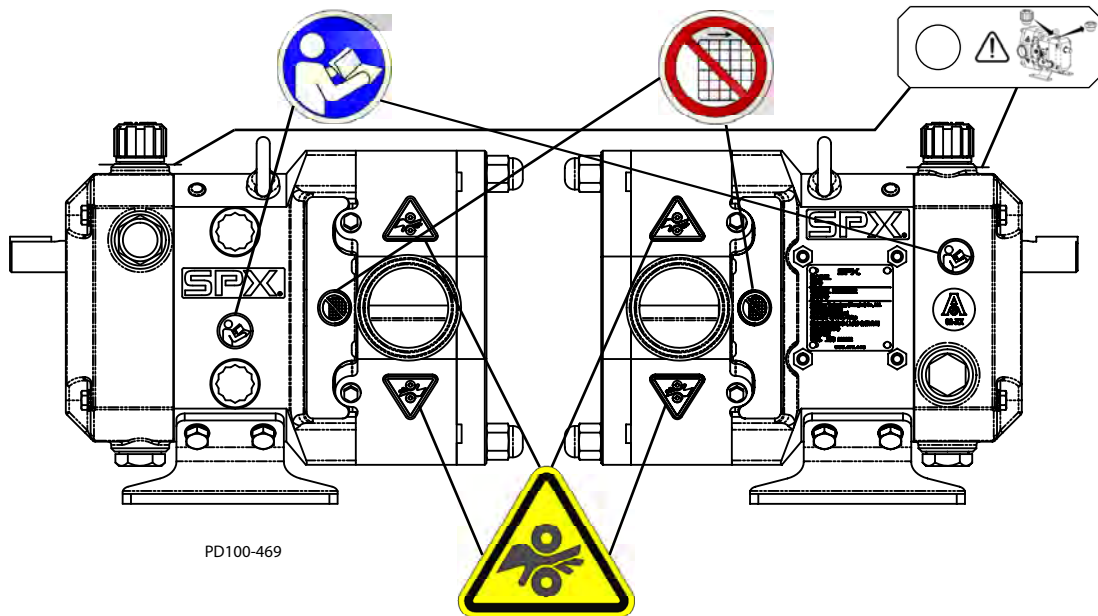

Application Instructions

Apply to a clean, dry surface. Remove the backing from the label, place it in proper position, protect it with a cover sheet and burnish it. (A soft rubber roller also may be used to press the label into place.) Apply all labels to be readable from the front of the pump.



PD100-469

Figure 1 - Label locations

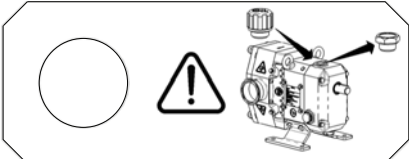
Label	Definition
	<p>Consult operation manual</p>
	<p>Do not operate with guard removed</p>
	<p>Entanglement hazard</p>
	<p>Replace plug with breather plug.</p>

Care of Stainless Steel

NOTE: SPX recommends the use of an FDA-approved anti-seize compound on all threaded connections.

Stainless Steel Corrosion

Corrosion resistance is greatest when a layer of oxide film is formed on the surface of stainless steel. If film is disturbed or destroyed, stainless steel becomes much less resistant to corrosion and may rust, pit or crack.

Corrosion pitting, rusting and stress cracks may occur due to chemical attack. Use only cleaning chemicals specified by a reputable chemical manufacturer for use with 300 series stainless steel. Do not use excessive concentrations, temperatures or exposure times. Avoid contact with highly corrosive acids such as hydrofluoric, hydrochloric or sulfuric. Also avoid prolonged contact with chloride-containing chemicals, especially in presence of acid. If chlorine-based sanitizers are used, such as sodium hypochlorite (bleach), do not exceed concentrations of 150 ppm available chlorine, do not exceed contact time of 20 minutes, and do not exceed temperatures of 104°F (40°C).

Corrosion discoloration, deposits or pitting may occur under product deposits or under gaskets. Keep surfaces clean, including those under gaskets or in grooves or tight corners. Clean immediately after use. Do not allow equipment to set idle, exposed to air with accumulated foreign material on the surface. Corrosion pitting may occur when stray electrical currents come in contact with moist stainless steel. Ensure all electrical devices connected to the equipment are correctly grounded.

Elastomer Seal Replacement Following Passivation

Passivation chemicals can damage product contact areas of equipment. Elastomers (rubber components) are most likely to be affected. Always inspect all elastomer seals after passivation is completed. Replace any seals showing signs of chemical attack. Indications may include swelling, cracks, loss of elasticity or any other noticeable changes when compared with new components.

Introduction



DANGER: The pump contains internal moving parts. DO NOT put hands or fingers into the pump body ports or drive area at any time during operation. To avoid serious injury, DO NOT install, clean, service, or repair the pump unless all power is off and locked out.

Pump Model Designation

TL	-	0100	-	01	-	01	-	01	-	02	-	01	-	02
1		2		3		4		5		6		7		8

1. Model Series: TL – Johnson Pump TLP Series
2. Pump Model Size: 0040, 0100, 0140, 0230, 0300, 0670, 0940, 2290, 3450
3. Port Connection Type: 01 – ISO2952 Clamp
02 – DIN 11851
4. Rotor: 01 – Stainless Steel Tri-Lobe
5. Cover: 01 – Standard
6. Product Seal Material:
01 – Carbon vs. Hardened Stainless Steel
02 – Silicon Carbide vs. Silicon Carbide
7. Double Mechanical Seal: 01 – No
02 – Yes – adds carbon outer seal
8. Product Contact O-Ring Material: 01 – FKM
02 – EPDM

The TLP Series pump meets 3-A and EHEDG standards for sanitation, design, and style.

Intended Use



CAUTION: Improper use of the pumps leads to:

- Damage
- Leakage
- Destruction
- Possible failures in the production process

The TLP Rotary Pump is exclusively intended for pumping liquids, especially in beverage and food installations as well as in comparable applications of the chemical, pharmaceutical and health care industries.

Its use is permissible only within the admissible pressure and temperature margins and under consideration of chemical and corrosive influences.

Any use exceeding the margins and specifications set forth is considered to be not intended. Any damage resulting therefrom is not within the responsibility of the manufacturer. The user will bear the full risk.

Pump Receiving

NOTE: Each pump is shipped from the factory with the gearbox sealed. Prior to operation, check the oil level and replace the uppermost oil drain plug with the supplied oil fill breather. See “Lubrication” on page 21 for oil type and quantity.

All ports are covered at the factory to keep out foreign objects during transit. If covers are missing or damaged, remove the pump cover for a thorough inspection of the fluid head. Be sure that the pumping head is clean and free of foreign material before rotating the shaft.

Pump Characteristics

These positive displacement, low-slip, stainless steel pumps are designed with larger diameter shafts for greater strength and stiffness, and are mounted on a heavy-duty cast iron bearing frame with double tapered roller bearings.

- Designed for continuous operation.
- Rotor connections are sealed from the product zone.
- Rotors are secured to the shafts using rotor nuts.
- Single mechanical seals are standard.
- CIP capability.

Equipment Serial Number

All pumps are identified by a serial number on the gear case nameplate. The serial number is also stamped on the pump body.

NOTE: The gear case and body must be kept together to maintain proper rotor clearance. Failure to do so will damage the pump.

Pump Shaft Location

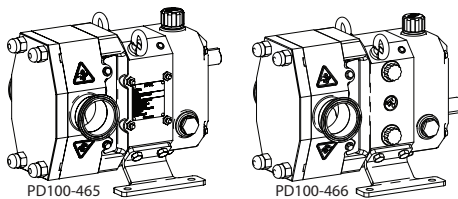

Figure 2 - Upper and Lower Shaft Mount

There are two pump drive shaft locations, as shown in Figure 2 and Figure 3. When side-mounted, left-hand as viewed from the pump cover (Figure 3), rotation may be reversed for up or down vertical flows. See also Figure 24 and Figure 25 on page 19.

The mounting position may be easily reconfigured by changing the location of the mounting feet. The breather plug must be moved to the uppermost port and the level indicator should be in the lowest, side port in the gear cover.

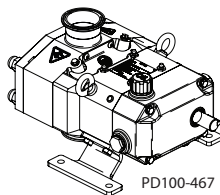
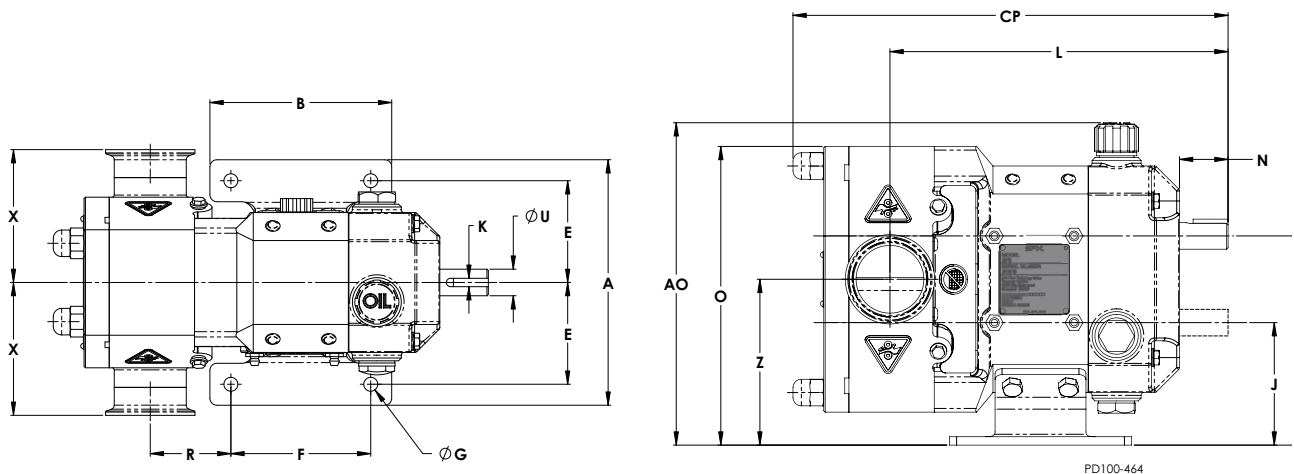

Figure 3 - Sidemount Left Hand (as viewed from pump cover)

Pump Dimensions



Mounting Dimensions

Model	A	AO	B	CP	D	E	F	G	J	K	L	N	O	R	U	X	Z
0040	175.5	230.5	130.0	281.4	149.6	72.8	100.0	10	87.6	6x6	227.6	34.7	231.6	43.5	19	98.0	118.6
0100	175.5	230.5	130.0	286.8	149.6	72.8	100.0	10	87.6	6x6	229.0	34.7	231.6	44.9	19	98.0	118.6
0140	175.5	230.5	130.0	298.7	149.6	72.8	100.0	10	87.6	6x6	235.8	34.7	231.6	51.7	19	98.0	118.6
0230	175.5	230.5	130.0	299.1	149.6	72.8	100.0	10	87.6	6x6	235.9	34.7	231.6	51.8	19	98.0	118.6
0300	175.5	230.5	130.0	311.1	149.6	72.8	100.0	10	87.6	6x6	241.8	34.7	231.6	57.7	19	98.0	118.6
0670	239.1	310.6	160.0	396.4	205.9	99.5	120.0	13	112.9	10x8	321.0	57.6	292.9	75.5	38	124.0	159.4
0940	239.1	310.6	160.0	423.9	205.9	99.5	120.0	13	112.9	10x8	332.6	57.6	292.9	87.1	38	134.0	159.4
2290	301.1	384.6	250.0	553.6	263.7	130.5	210.0	13	138.7	16x10	437.0	85.6	368.2	81.5	55	159.0	201.2
3450	301.1	384.6	250.0	605.6	263.7	130.5	210.0	13	138.7	16x10	463.2	85.6	368.2	107.7	55	159.0	201.2

Technical Data

Model	Displacement liter/rev	Nominal Connection Size	Differential Pressure Rating bar	Max. Pump Speed RPM	Input Shaft Diameter	Max. Torque N-m	Max. Temp. °C	Horizontal Mount Pump Weight	Vertical Mount Pump Weight
0040	0.04	25 (1")	10	1200	19	108	100	22	22
0100	0.10	25 (1")	10	900	19	108	100	22	22
0140	0.14	38 (1.5")	10	900	19	108	100	24	24
0230	0.23	38 (1.5")	10	900	19	108	100	24	24
0300	0.30	50 (2")	10	900	19	108	100	25	25
0670	0.67	50 (2")	10	700	38	400	100	65	65
0940	0.94	75 (3")	10	700	38	400	100	70	70
2290	2.29	100 (4")	10	600	55	1200	100	148	148
3450	3.45	150 (6")	10	600	55	1200	100	165	165

NOTE: All weights in daN, mass is kg.

Sound Level

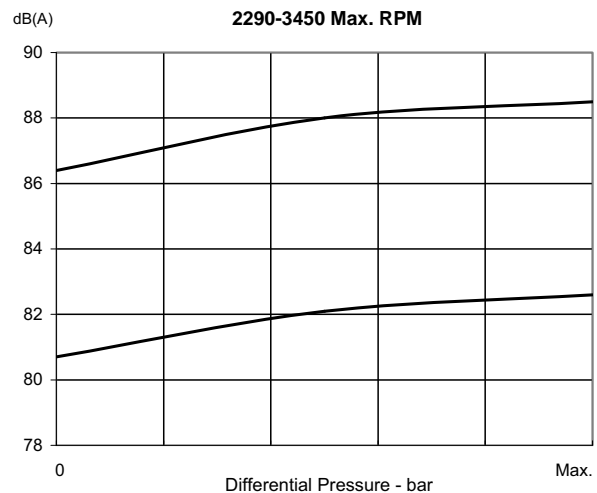
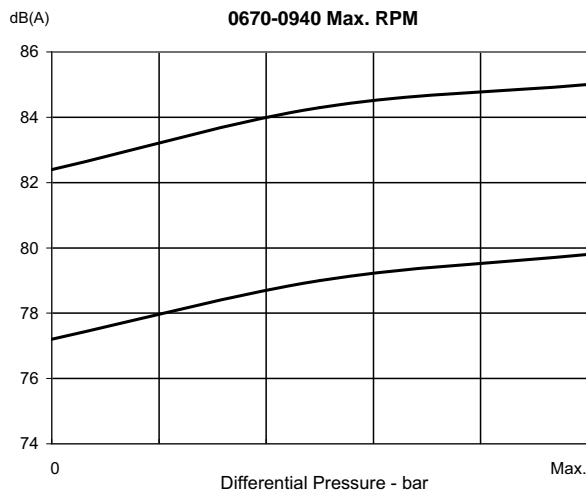
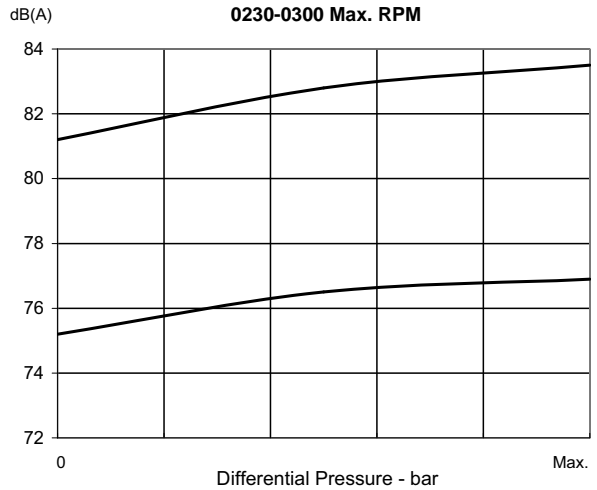
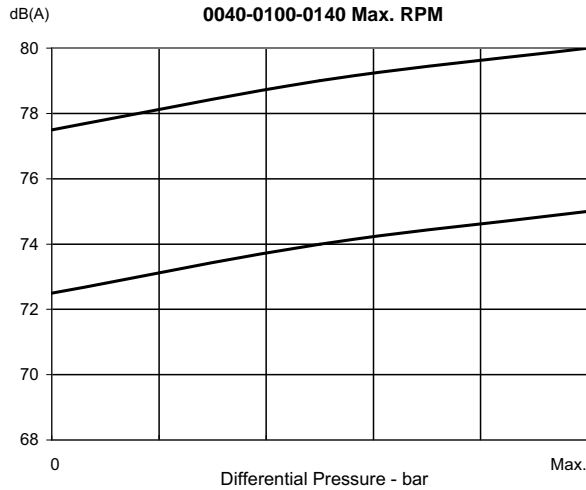

Maximum Particle Size

Model	Port Connection Inside Diameter (mm)	Max. Theoretical Particle Size (mm)	Recommended Max. Particle Size (mm)
0040	20	7.6	3
0100	26	15.6	5
0140	38	15.6	5
0230	38	25.6	9
0300	50	25.6	9
0670	50	38.5	13
0940	81	38.5	13
2290	100	45.6	15
3450	150	45.6	15

Installation

The installation of the pump and piping system should be in accordance with local codes and restrictions. Practices described in this manual are recommended for optimum performance.

All system equipment, such as motors, sheaves, drive couplings, speed reducers, etc., must be properly sized to ensure satisfactory operation of your pump within its limits.



CAUTION: These pumps are positive displacement, low slip design and will be severely damaged if operated with closed valves in discharge or inlet lines. The pump warranty is not valid for damages caused by a hydraulic overload from operation or start-up with a closed valve in the system.

Install Pump and Drive Unit



WARNING: Full guards must be installed to isolate operators and maintenance personnel from rotating components.

In a typical installation configuration, the pump and drive unit are mounted on a common base plate. The unit can be installed in any of the arrangements shown in Figure 4 through Figure 7 (the shaded area indicates the guard location).

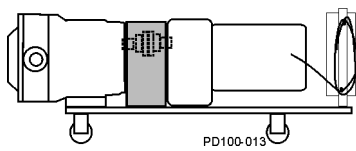

Figure 4 - Portable Base

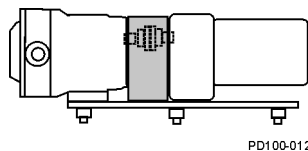

Figure 5 - Adjustable Leg Base

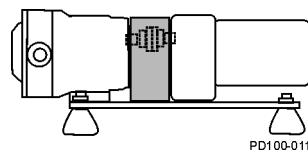

Figure 6 - Leveling and/or Vibration Isolation Pads

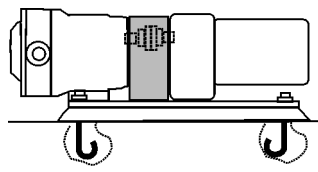

Figure 7 - Permanent Installation on Foundation

NOTE: When installing unit as shown in Figure 7, level the unit before installing the bolts.

Install Connections and Piping

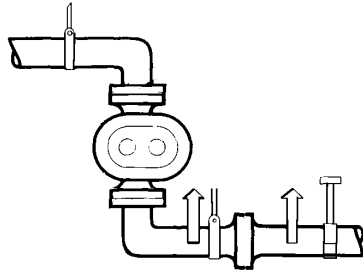
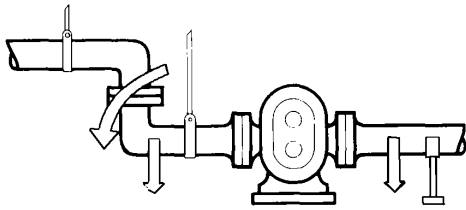

Figure 8 - Piping Support

Piping Support

To minimize forces exerted on the pump, support all piping to the pump independently with hangers or pedestals. Such forces can cause misalignment of the pump parts and lead to excessive wear of rotors, bearings, and shafts.

Figure 8 shows typical supporting methods used to independently support each pipe, reducing the weight effect of piping and fluid on the pump.

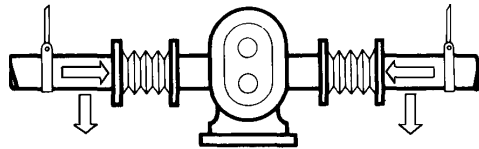

Figure 9 - Flexible Connections and Supports

Expansion Joints

Thermal expansion of piping can cause tremendous forces. Use thermal expansion joints to minimize these forces on the pump.

Flexible joints can be used to limit transmission of mechanical vibration. Ensure that the free ends of any flexible connections in the system are anchored.

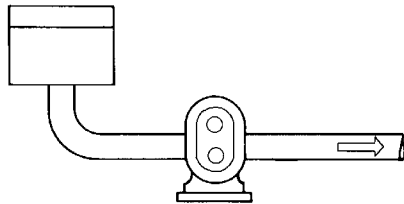

Figure 10 - Pump Below Supply

Inlet Piping

Install the pump below the supply liquid level to reduce the air in the system by flooded suction (Figure 10).

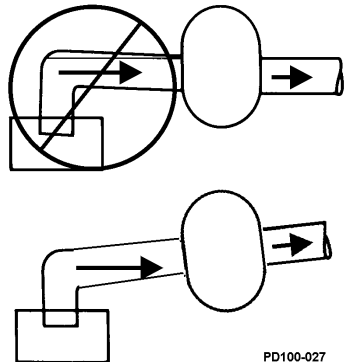
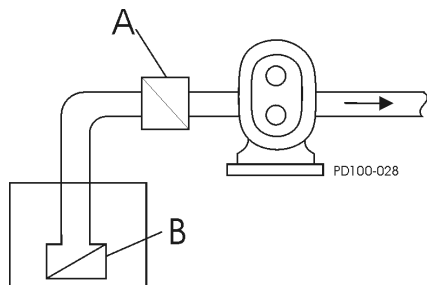

Figure 11 - Correct Piping to Prevent Inlet Air Pockets

If the pump is installed above the supply liquid level, the piping on inlet side must slope up toward the pump, preventing air pockets in the pipes (Figure 11).

Install Check Valves



A. Inlet Check Valve
B. Foot Check Valve

Figure 12 - Inlet Check Valve

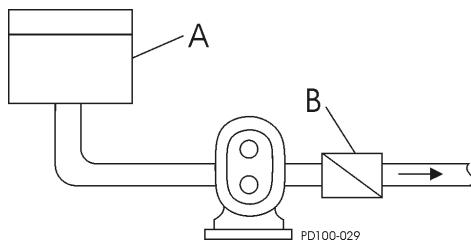

A. Closed Tank - produces a vacuum on liquid (Low Absolute Pressure)
B. Check Valve (outlet)

Figure 13 - Discharge Check Valve

Inlet Side on Lift Applications

Use check valves to keep the inlet line full, particularly with low-viscosity fluids (Figure 12).

Discharge Side

For systems with liquid under a vacuum, we recommend installing a check valve on the discharge side of the pump. The check valve prevents backflow (air or fluid) to aid in the initial start-up by minimizing the required differential pressure supplied by the pump to start the flow (Figure 13).

Install Isolation Valves

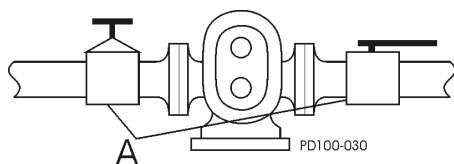

Figure 14 - Isolation Valves

Isolation valves permit pump maintenance and safe pump removal without draining the system (Figure 14, item A).

Install Relief Valves

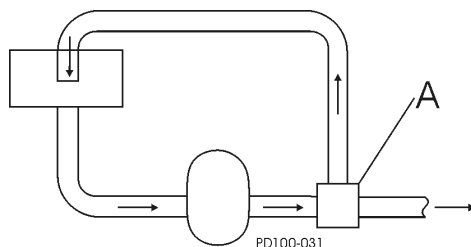
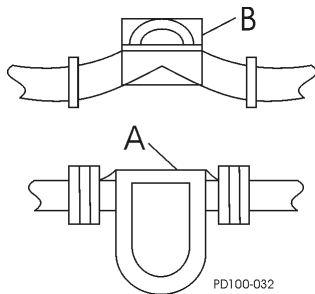

Figure 15 - Relief Valves

Install relief valves to protect the pump and piping system against excessive pressure. We recommend installing an external relief valve designed to bypass fluid from the pump outlet to the inlet side of the system (Figure 15, item A).

Inlet Side Strainers and Traps



A. Strainer B. Magnetic Trap

Figure 16 - Inline Strainers and Traps

Inlet side strainers and traps (Figure 16, items A and B) can be used to prevent foreign matter from damaging the pump. Make the selection carefully to prevent cavitation caused by the restriction of the inlet. If the inlet strainers are used, they must be serviced regularly to prevent clogging and flow stoppage.

Install Pressure Gauges

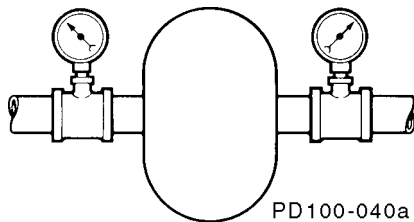

Figure 17 - Pressure and Vacuum Gauges

Pressure and vacuum gauges provide valuable information about pump operation (Figure 17). Wherever possible, install the gauges to help provide information on the following:

- Normal or abnormal pressures
- Indication of flow
- Changes in pump condition
- Changes in system conditions
- Changes in fluid viscosity

Seal Flush Connections

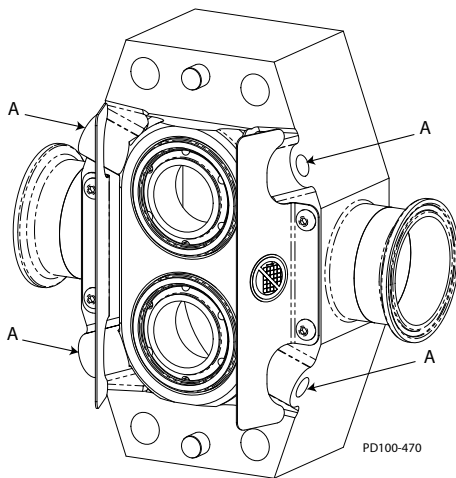

Figure 18 - Flush Piping Setup

Pumps with double seals require flushing. The flush media (typically water) must be connected and flowing whenever pump is operated.



WARNING: Operating the pump without flush will damage the seal and pump parts due to excess heat from dry running.

Pump bodies have four G 1/8 BSPT flush connections located near the bottom and top of the body (Figure 18, item A).

1. Flushing media may be piped into either side for both shaft seals and discharged to drain on opposite side.
2. Both inlets may be manifolded to simplify piping. Be sure flush water is flowing out both discharge lines.
3. Use cool, filtered flush media to obtain maximum service life of seal components. If the pumped product is sticky or solidifies at room temperature, use warm or hot media.
4. Install a pressure reducing valve and flow control valve (needle valve) on the flush supply line. Set the supply pressure at a maximum of 2 bar (30 psi) and adjust the flow rate to approximately 0.9 lpm (1/4 gpm) (more for high temperature applications).

- A solenoid valve also should be installed in the flush supply and wired in series with the motor starter to provide automatic start/stop of the flush media flow before the motor turns on and after motor turns off.

CIP (Clean-In-Place) Guidelines

These optional CIP (Clean-In-Place) guidelines are designed to provide complete access of CIP solutions to all product contact surfaces:

- Ensure that the velocity rate of CIP solutions is adequate to clean the entire circuit. For most applications, a velocity of 1.5 m/sec (5 ft./sec) is sufficient. For the CIP solution to achieve the proper velocity, the pump drive must have enough speed range and horsepower. The required inlet pressure also must be satisfied. If the pump does not supply enough CIP solution velocity, a separate CIP supply pump with an installed bypass may be used. To determine the appropriate bypass arrangement, contact Application Engineering.
- Ensure that a differential pressure is created across the pump. Differential pressure will push CIP solutions through close-clearance areas of the pump, resulting in better cleaning action. The high pressure side may be either the inlet or outlet side. 2 bar (30 psi) differential pressure is adequate for most applications.
- The pump must be operated during CIP to increase turbulence and cleaning action within the pump. If complete draining is required, the pump must be in the side mount position.

Check Coupling Alignment

Pump and drive coupling alignment **must** be rechecked after the complete unit has been installed and piping completed. Periodic rechecking is advisable during the pump service life.

- We recommend using a flexible coupling to connect the drive to the pump. Several different types are available, including couplings with slip or overload provision. Flexible couplings can be used to compensate for end play and small differences in alignment.
- Align the pump and drive shaft as closely as possible.

Check Angular Alignment

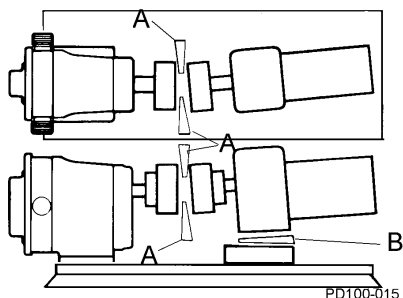

Figure 19 - Check Angular Alignment

- Using feeler gauges or taper gauges (Figure 19, items A and B), check the alignment at four points every 90 degrees around the coupling; **adjust to equal dimension at all points.**
- Set the space between the coupling halves to the manufacturer's recommended distance.
- Install shims to bring the system into alignment.

Check Parallel Alignment

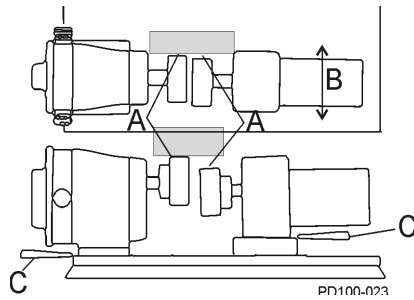

Figure 20 - Check Parallel Alignment

1. Check both the horizontal and vertical alignment of the pump and drive using a straight edge.
2. Using a feeler gauge at location "A" in Figure 20, determine the direction and amount of movement needed (Figure 20, item B).
3. If necessary, shim at location "C" and/or move drive as needed.

Check Belt and Chain Drive Alignment

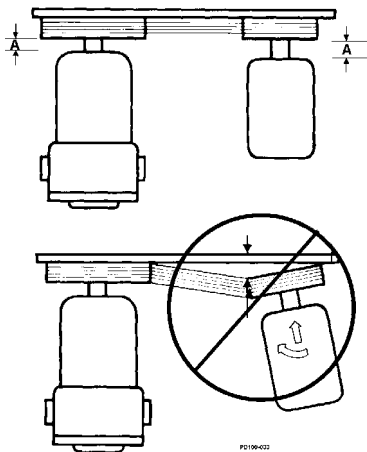

Figure 21 - Aligning Belt and Chain Drives

Use a straight edge to visually check the belt or chain alignment. Keep the shaft distance to a minimum (Figure 21, item A).

After the piping is complete and before the belts are installed, manually turn the pump shaft to ensure that it turns freely.

Check Pump Rotation

Check the rotation direction of the drive to determine the rotation direction of pump (Figure 22 through Figure 25).

After verifying the correct drive rotation, connect the coupling and assemble the pump and coupling guards.

NOTE: The pump covers in the following figures have been removed to view the rotor rotation. Never operate the pump with the covers removed.

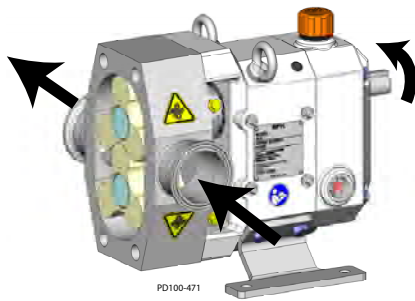

Figure 22 - Upper Shaft Drive Flow

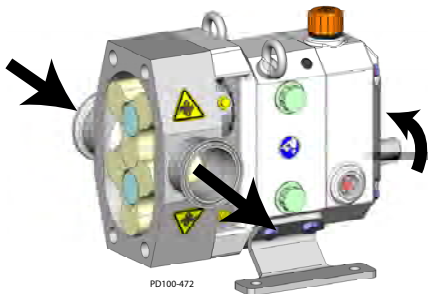

Figure 23 - Lower Shaft Drive Flow

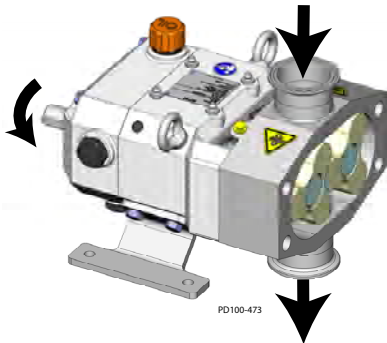

Figure 24 - Vertical Porting Flow

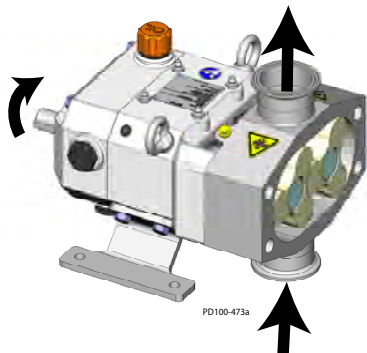

Figure 25 - Pump Rotation

Operation



DANGER: The pump contains internal moving parts. DO NOT put hands or fingers into the pump body ports or drive area at any time during operation. To avoid serious injury, DO NOT install, clean, service, or repair the pump unless all power is off and locked out.



CAUTION: These pumps are positive displacement, low slip design and will be severely damaged if operated with closed valves in the discharge or inlet lines. The pump warranty is not valid for damages caused by a hydraulic overload from operation or start-up with a closed valve in the system.

Pre-Startup Checklist



CAUTION: Do not use this pump to flush a newly- installed system. Severe damage may occur to the pump and system if the pump is used to flush the system. **Remove the rotors during system flushing.**



WARNING: Full guards must be installed to isolate the operators and maintenance personnel from the rotating components. Guards are provided with TLP pumps as part of a complete pump and drive package.



WARNING: Do not start a pump with seal flush unless the seal flush is installed and on.

1. Ensure that the pump is correctly installed as described in “Installation” on page 13. Review “Install Relief Valves” on page 15 and install relief valves as needed.
2. Check the coupling alignment. See “Check Coupling Alignment” on page 17.
3. Ensure that the pump and piping are clean and free of foreign material such as welding slag, gaskets, etc.
4. Ensure that all piping connections are tight and leak-free. Where possible, check the system with non-hazardous fluid.
5. Ensure that the pump and drive are lubricated. See “Lubrication” starting on page 21.
6. Ensure that all guards are in place and secure.
7. Double mechanical seals require adequate supply and flow of clean flushing fluids.
8. Ensure that all valves are open on the discharge side and a free flow path is open to the destination.
9. Ensure that all valves are open on the inlet side and fluid can fill the pump. A flooded suction installation is recommended.
10. Check the direction of pump and drive rotation to ensure that the pump will rotate in the proper direction. See “Check Pump Rotation” on page 19

Startup Procedure

1. Start the pump drive. Where possible, start at a slow speed or jog.
2. Ensure that the liquid is reaching the pump within 60 seconds. If pumping does not begin and stabilize, check “Troubleshooting” on page 43.

Shutdown Procedure

1. Shut off the power to the pump drive.
2. Shut off the supply and discharge lines.

Emergency Shutdown Procedure

Emergency Shutdown Procedures should be documented by plant personnel after assessing system-wide requirements.

Maintenance

Important Safety Information



DANGER: The pump contains internal moving parts. DO NOT put hands or fingers into the pump body ports or drive area at any time during operation. To avoid serious injury, DO NOT install, clean, service, or repair the pump unless all power is off and locked out.

Before detaching port connections to the pump:

- Close suction and discharge valves.
- Drain pump and clean or rinse, if necessary.
- Disconnect or shut off the electrical supply and lock out all power.

Lubrication

Table 1: Callout table for Figure 26

30. Oil Fill Breather
31. Oil Level Check Plug, Sightglass
32. Oil Drain Plug
33. Grease Fittings
39. Grease Clean-out Plug

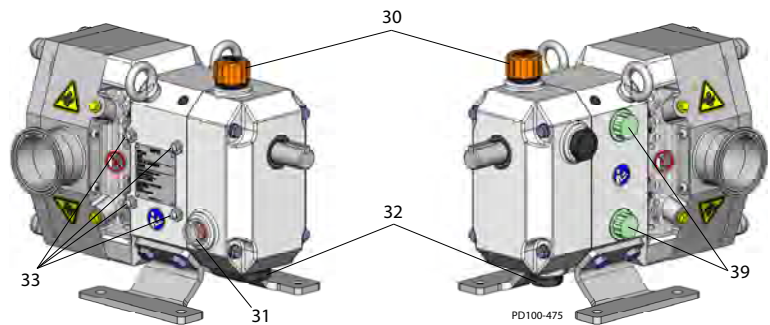

Figure 26 - Lubrication Points

Drive Lubrication

Refer to the manufacturer's manual shipped with the drive for proper drive lubrication and frequency.

Gear Oil

Refer to the table below for the required capacity per pump model as shown.

Change the oil every 1000 hours.

Gear Oil Specification

ISO Grade 320, SAE 140 or AGMA Number 6EP

Table 2: Gear Oil Volume

Model	Gear Oil Volume	
	Horizontal Ports	Vertical Ports
0040, 0100, 0140, 0230, 0300	100 ml	170 ml
0670, 0940	325 ml	490 ml
2290, 3450	625 ml	1125 ml



CAUTION: Each pump is shipped from the factory with the gearbox sealed. Prior to operation, check the oil level and replace the uppermost oil drain plug with the supplied oil fill breather, at the location of item 30 in Figure 26.

Bearing Lubrication

Bearings are factory-lubricated with grease. Table 3 provides approximate volumes for adequate re-greasing. **Grease the bearings every 250 hours.**

Excess grease will accumulate in the gear case. Remove it through the cleanout hole covered with a plastic plug (Figure 26, item D on page 21).

Bearing Lubricant Grease

NLGI Grade No. 2, EP, Lithium-based lubricant

Table 3: Grease Quantity

Model	Grease Quantity Per Bearing	
	Front Bearing	Rear Bearing
0040, 0100, 0140, 0230, 0300	5 ml	4 ml
0670, 0940	10 ml	9 ml
2290, 3450	17 ml	14 ml

Maintenance Inspections

STOP DANGER: The pump contains internal moving parts. DO NOT put hands or fingers into the pump body ports or drive area at any time during operation. To avoid serious injury, DO NOT install, clean, service, or repair the pump unless all power is off and locked out.

Detecting wear in the early stages can reduce repair costs and down time. A simple “look-feel” inspection of the pump during breakdown cleaning is recommended to detect signs of trouble at an early stage.

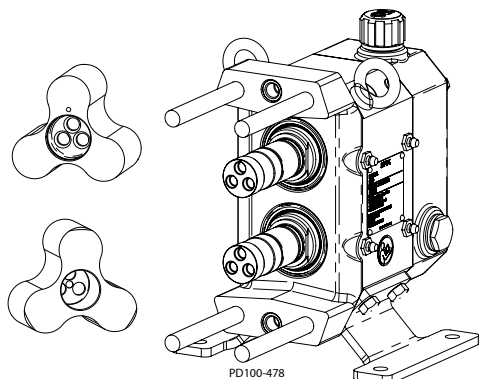

Figure 27 - Check for Wear

Inspection of Shaft

Visually inspect the shaft for twists or bends; replace it as necessary.

Inspection of Hub End

Visually inspect the rotor hub end for excessive wear; replace it as necessary. Each time the rotors are removed, replace the o-rings on the hub.

Inspection of Shaft Shoulder

Visually inspect the shaft shoulder for excessive wear and replace it as necessary. If the shaft shoulder has a sharp edge, remove the edge with a file to prevent cutting the shaft o-ring on installation

Inspection of Gears and Bearings

NOTE: The rotor hub and shaft shoulder wear are caused by operating with a loose rotor lug screw(s) for extended periods.

Gear backlash

With the fluid head and seals removed, feel for gear backlash by rotating either shaft by hand. The other shaft must engage immediately. Perform this check three times at 60-degree intervals.

If play (backlash) is evident, remove the gear case cover, check the gear teeth for wear and ensure that the gear is not loose on the shaft. If the gear teeth are worn, replace the gears.

If the gear is loose on the shaft, inspect the shaft key and key-way; replace as necessary.

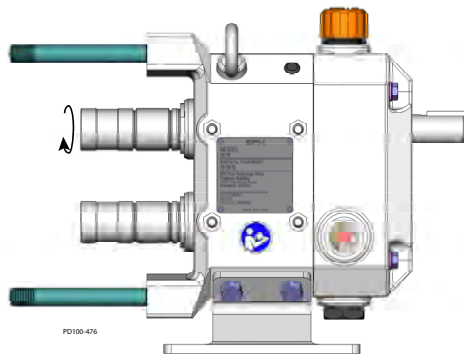

Figure 28 - Backlash Check

Check bearing condition

With the fluid head and seals removed, check the bearing condition by applying (by hand) an up or down force of approximately 30 lbs (14 kg). If movement is detected, the bearing may be failing.

Check the shaft movement forward or backward. When the bearing is determined to be failing, replace the bearing and review the lubrication schedule.

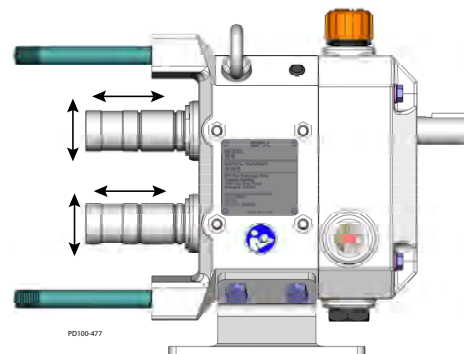

Figure 29 - Bearing Deflection Check

Recommended Maintenance Schedule

Item	Maintenance Interval
Replace Gear Oil	Every 1000 hours. See “Gear Oil” on page 21.
Grease Bearings	Every 250 hours. See “Bearing Lubrication” on page 22.
Replace O-Rings	Every time o-rings are removed.

NOTE: For seals and rotors, component life varies widely between different applications. Inspect for wear and replace as needed. See *“Maintenance Inspection Chart”* on page 24.

Maintenance Inspection Chart

Problem	Possible Causes	Possible Solutions
Rotor to rotor contact or uneven rotor to rotor clearance.	Hard object jammed into rotors and twisted shafts.	Replace shafts. Install strainers if necessary. Check and replace gears if necessary.
Worn rotor hub end or shaft shoulder.	Loose rotor lug screw(s). Rotors slammed against shoulder when installed.	Torque rotor lug screw(s). See "Torque Reference" on page 42. Replace rotors and shafts or shim shafts to maintain proper backface clearances.
Sharp edged shaft shoulder.	Loose rotor lug screw(s). Rotors slammed against shoulder when installed. Backface clearances not even.	Remove sharp edge with file to prevent cutting shaft o-ring. Verify backface clearances are even.
Gear backlash.	Lack of lubrication. Excessive hydraulic loads.	Check lubrication level and frequency. Reduce hydraulic loads. Check and replace gears if necessary.
Worn or broken gear teeth.	Lack of lubrication. Excessive hydraulic loads.	Check lubrication level and frequency. Reduce hydraulic loads. Check and replace gears if necessary.
Loose bearings, axially or radially.	Lack of lubrication. Excessive hydraulic loads. Product or water contamination.	Check lubrication level and frequency. Reduce hydraulic loads. Ensure no excess grease build-up. Replace bearings if necessary.
Damaged front grease seals.	Seal may be old and worn. No grease on lips to lubricate. Shaft worn under seals.	Replace seals. Properly lubricate with grease when installing. Inspect shaft surface under seals.
Damaged rear oil seals.	Seal may be old and worn. No grease on lips to lubricate. Shaft worn under seals.	Replace seals. Properly lubricate with grease when installing. Inspect shaft surface under seals.

Cleaning

The pump cleaning schedule should be determined on-site for the materials being processed and the plant maintenance schedule. For CIP cleaning, see "CIP (Clean-In-Place) Guidelines" on page 17.

To disassemble the fluid head, see "Pump Disassembly - Hydraulic Components" on page 25. Remove and clean the cover o-ring, pump seals, and the rotor lug screws. Inspect and replace them as necessary.

NOTE: Always replace the rotor cap o-rings and rotor hub o-rings when reassembling the pump. If the area behind these seals becomes soiled, contact Application Engineering for a specific cleaning and sanitizing procedure validated to remove bacteria.

In applications where material can harden in the pump during shutdown, a CIP cleaning, flush, or disassembly of the fluid head and manual cleaning is strongly recommended.

Pump Disassembly - Hydraulic Components



DANGER: The pump contains internal moving parts. DO NOT put hands or fingers into the pump body ports or drive area at any time during operation. To avoid serious injury, DO NOT install, clean, service, or repair pump unless all power is off and locked out.



DANGER: To avoid serious injury, shut off and drain product from the pump prior to disconnecting the piping.

Table 4: Callout table for Figure 30

2. Cover
3. Rotor
4. Rotor nut
5. Rotor screw cap
35. Acorn nut
51. Cover o-ring
55. Rotor screw cover o-ring

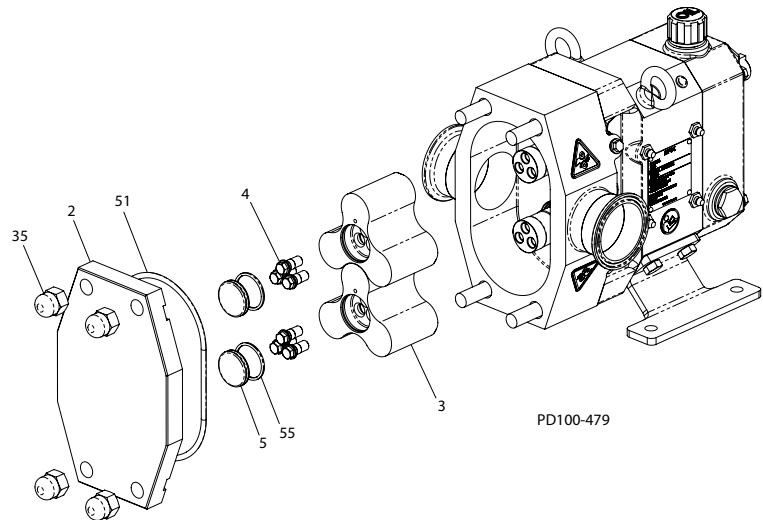

Figure 30 - Pump Cover and Rotor Removal

Pump Cover Removal

1. Remove the cover acorn nuts (Figure 30, item 35).
2. Remove the cover (item 2). Cavities are provided on the mounting surface of the cover to permit removing the cover with the aid of a screwdriver.
3. Remove and inspect the o-ring (item 51).

Rotor Removal

1. Remove the screw caps (Figure 30, item 5) from the rotors (item 3). Remove and inspect the o-rings (item 55).
2. Remove the rotor lug screws (item 4). To prevent the rotors from turning while loosening (or tightening) the rotor lug screws, block the rotors following the guidelines provided in the "Rotor Blocking" section on page 26.
3. Remove the rotors (Figure 30, item 3). If the rotors cannot be removed by hand, use a twisting motion to break them free. If unsuccessful, tap the body forward using a mallet to loosen the rotors.

NOTE: The rotor mounted on the drive shaft is marked with an "X" in the lug screw counterbore (see Figure 31). The marked rotor must always be installed on the drive shaft to maintain proper rotor clearance and prevent pump damage.

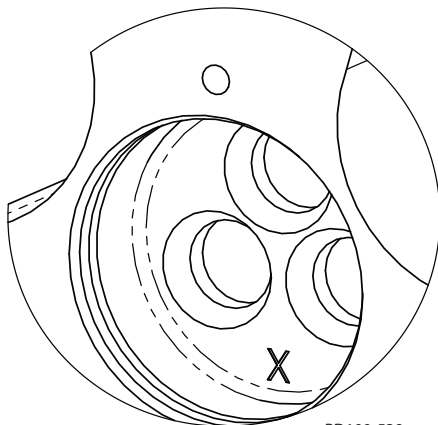

Figure 31 - Counterbore Detail

Table 5: Rod diameters

Model	Rod Diameter
0040	15
0100, 0140	20
0230, 0300	30
0670, 0940	45
2290, 3450	60

Rotor Blocking

1. Use a rod made of a non-marring material to block the rotors and prevent them from turning. A plastic rod works well for this purpose. Table 5 lists rod diameters by model for rotor blocking. Always block the rotor against the body, not against the opposite rotor. See Figure 32.

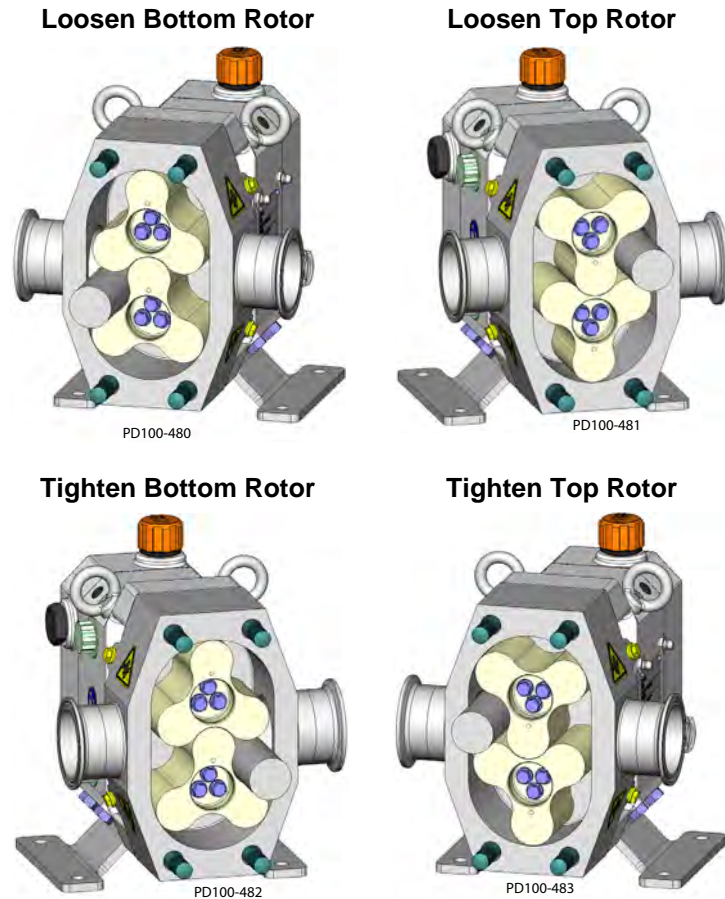

Figure 32 - Rod Positions for Blocking

Pump Body Removal

1. Using a mallet, tap the body forward until the dowels are free of the gear case (Figure 33, item 11).
2. Carefully slide the body off of the studs (item 34) to prevent damaging the mechanical seal components.
3. Place the body on a protected surface with the seals facing up.
4. Remove and inspect the rotor hub o-rings (item 53).

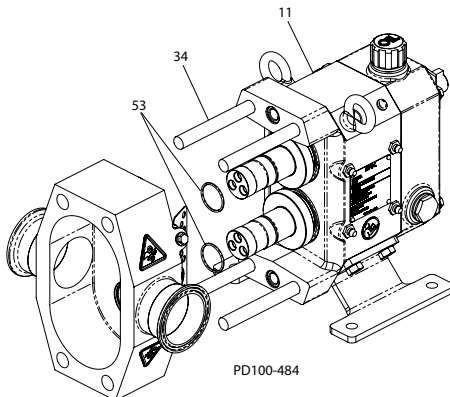
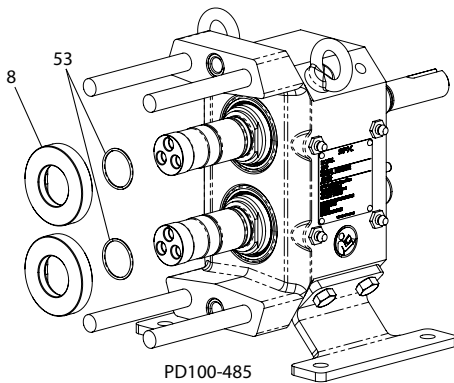
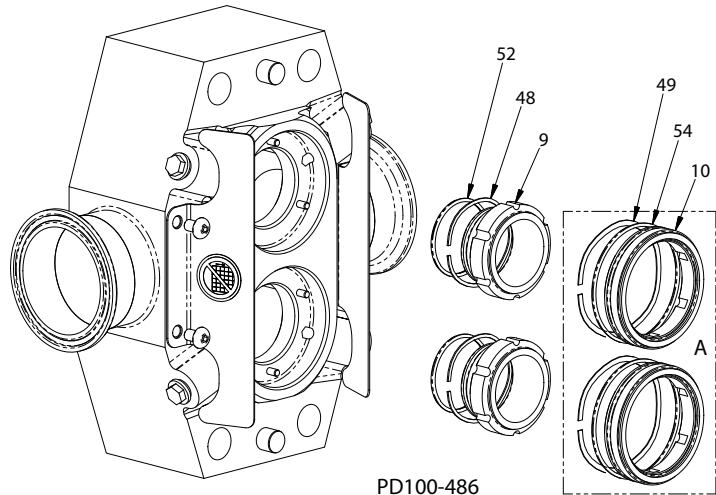

Figure 33 - Pump Body Removal

Mechanical Seal Removal

1. Remove the seal seats (Figure 34, item 8) from the shafts. Take care to prevent damage to the seats or shafts.
2. Remove and inspect the o-rings (item 53).

**Figure 34 - Remove Seal Seats****Figure 35 - Remove Seals**

3. Remove the inner seal (Figure 35, item 9) and wave spring (item 48). Remove the o-ring (item 52) from the inner seal and inspect it. Replace as necessary.
4. On pumps equipped with double mechanical seals (Figure 35, inset A), remove the outer seal (item 10) and wave spring (item 49). Remove the o-ring (item 54) from the outer seal and inspect it. Replace as necessary.

Gearbox Disassembly



DANGER: To avoid serious injury, DO NOT install, clean, service, or repair the pump unless all power is off and locked out.



DANGER: To avoid serious injury, shut off and drain product from the pump prior to disconnecting piping.

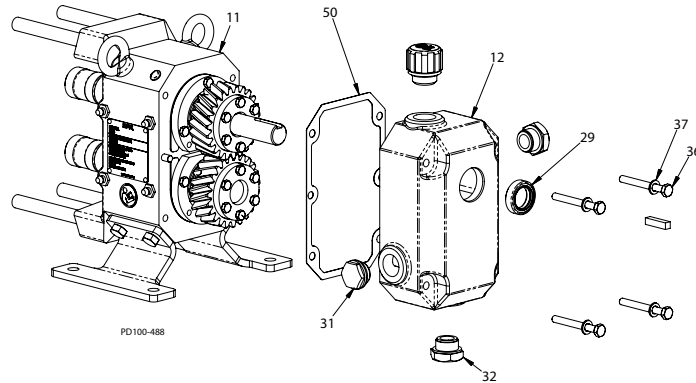

Figure 36 - Remove Gear Case Cover

Gear Cover Removal

1. Remove the bottom drain plug (Figure 37, item 32) and drain the oil into an appropriate container. Dispose of the used oil in accordance with local requirements.
2. Remove the input shaft key (if present) and remove any burrs or sharp edges from the input shaft.
3. Remove the cap screws (Figure 36, item 36) and washers (item 37) and remove the cover (item 12).
4. Remove the input shaft seal (item 29) from the gear cover and discard it.
5. Inspect the level indicator plug (item 31) and replace it if it appears cloudy or stained.
6. Remove the gasket (Figure 36, item 50) and discard it. Carefully scrape any gasket residue from the mating surfaces of the gear cover (item 12) or gear case (item 11).

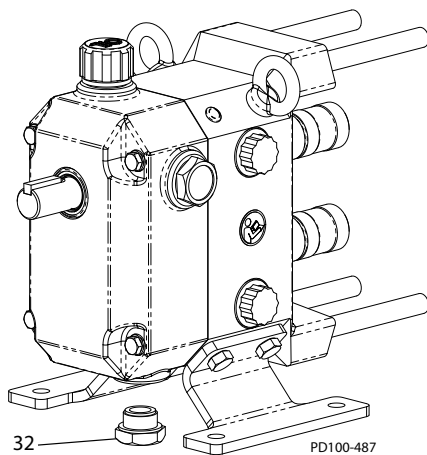
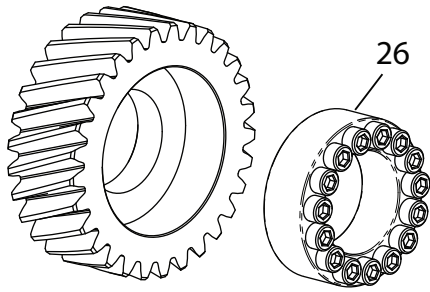
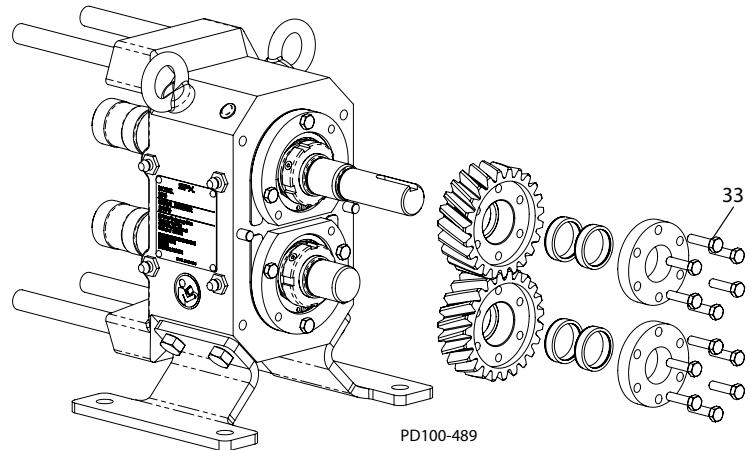

Figure 37 - Remove Oil Drain Plug

Gear and Shaft Removal



PD100-490
Figure 38 - Locking Assembly



PD100-489
Figure 39 - Remove Gear and Locking Assembly

1. Loosen the clamp ring screws (Figure 39, item 24) or locking screws in the locking assembly (Figure 38, item 26) to release the gear from the shaft.

2. Remove the gear and locking assembly from the shaft.

3. Repeat steps 1-2 for the other shaft.

4. Remove the bearing case screws (Figure 40, item 41).

5. Install 2 screws in the tapped holes (Figure 40, item A) in the bearing case (item 14). Tighten the screws to pull the bearing case from the gear case. (Figure 41).

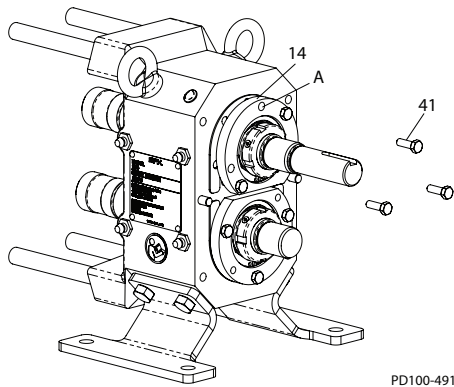

PD100-491
Figure 40 - Remove Screws

6. Repeat steps 4-5 for the other shaft.

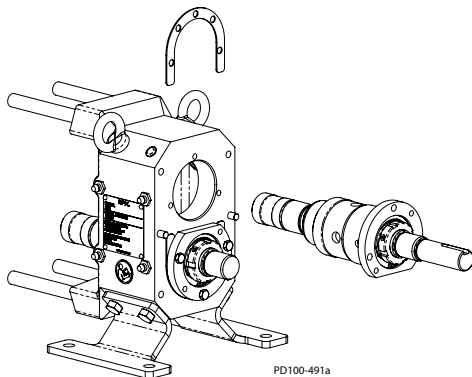

PD100-491a
Figure 41 - Remove Shaft

Bearing Removal

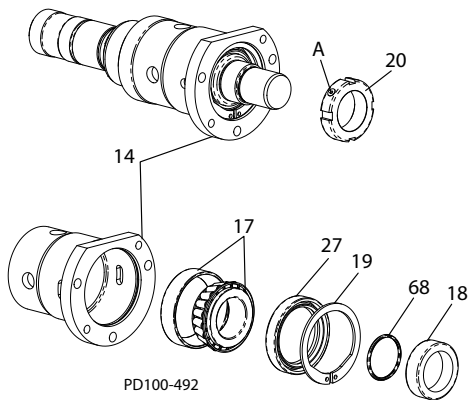

Figure 42 - Remove Bearings

1. Loosen the locking setscrew(s) (Figure 42, item A) in the bearing adjustment nuts (item 20) and remove the bearing adjustment nuts.
2. With the bearing case supported as shown in Figure 43, press the shaft free of the rear bearing (item 17), bearing case (item 14), seal sleeve o-ring (item 68), and seal sleeve (item 18).
3. Remove the retaining ring (item 19) from the bearing case and press the rear bearing cup and rear bearing seal (item 27) out of the bearing case.
4. Press the front bearing cone off of the shaft.
5. Repeat the steps above for the other shaft.

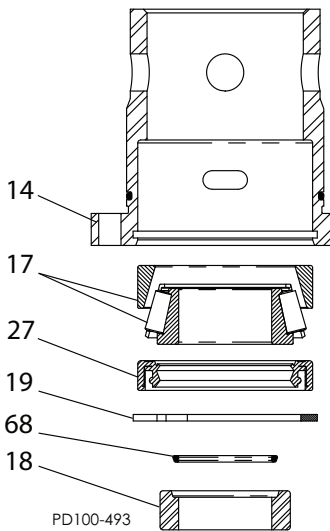

Figure 43 - Press Shaft Free of Rear Bearing

Pump Assembly

NOTE: Use care at all times to prevent damage to critical machined surfaces.

NOTE: Check the components for sharp edges or burrs. Remove them as required.

Install Front Seals

Install new front bearing seals (Figure 44, item 28) into the gear case (item 11) with the primary lip facing toward the inside of the gear case. The seals should be flush with the face of gear case.

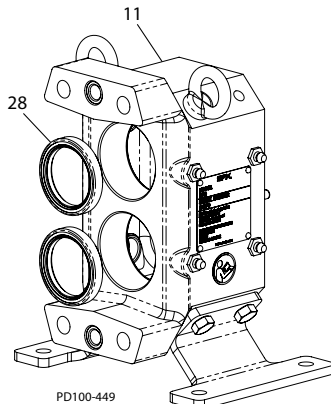

Figure 44 - Install Front Seals

Bearing Assembly

1. Press the rear bearing cup (Figure 46, item 17) into the bearing case (item 14) using a pusher tool (item A).

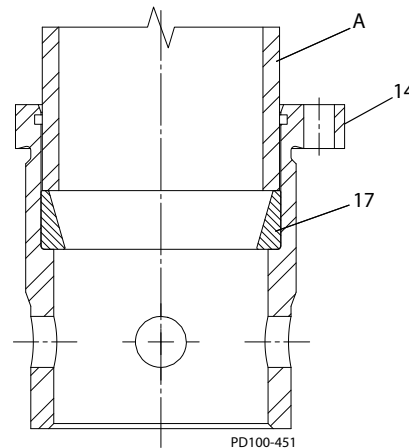

Figure 46 - Press Rear Bearing Cup

2. Heat the bearing cone to 120°C and place it on the shaft.

Alternate method: Press the front bearing cone (Figure 45, item 16) onto the shafts (items 6-7). The bearing cone must seat squarely against the shaft shoulder.

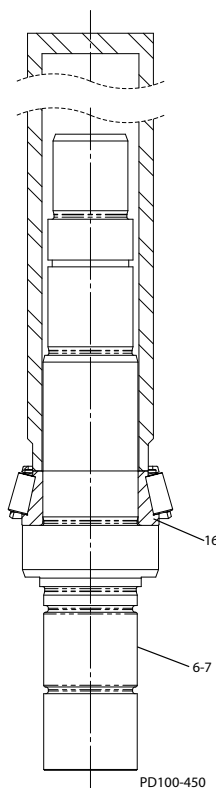

Figure 45 - Press Bearing Cone Onto Shaft

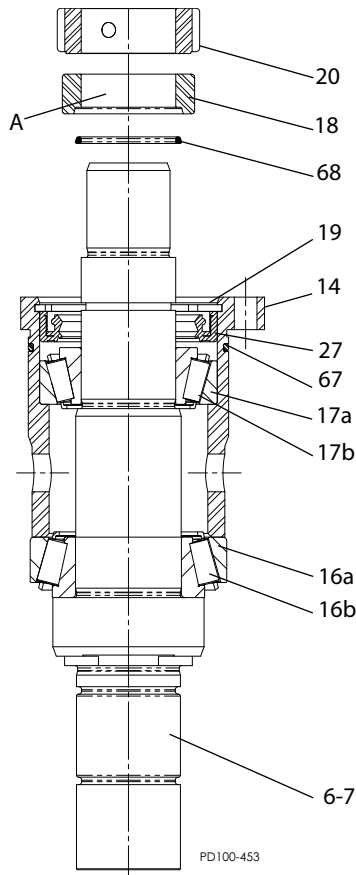

Figure 47 - Bearing Assembly

3. Install the front bearing cup (Figure 47, item 16a) onto the mounted cone (item 16b), followed by the bearing case (item 14).
4. Press the rear bearing cone (item 17b) onto the shaft and into the cone.
5. Press the rear seal (item 27) into the bearing case (item 14) with the primary lip facing away from the bearing, and install the retaining ring (item 19). Orient the seal as shown and make sure it does not interfere with the bearing.
6. Install the o-ring (item 68) and seal sleeve (item 18) onto the shaft as shown in Figure 47. Orient the seal sleeve with the groove toward the bearing.
7. Install the bearing adjustment nut (item 20) and tighten "hand tight." Do not tighten the locking setscrews at this time.
8. Install the o-ring (item 67) into the groove of the bearing case (item 14).

Bearing Adjustment

1. See Figure 48. Apply a coating of bearing grease to the inside diameter (item A) of the front lip seals (item 29).

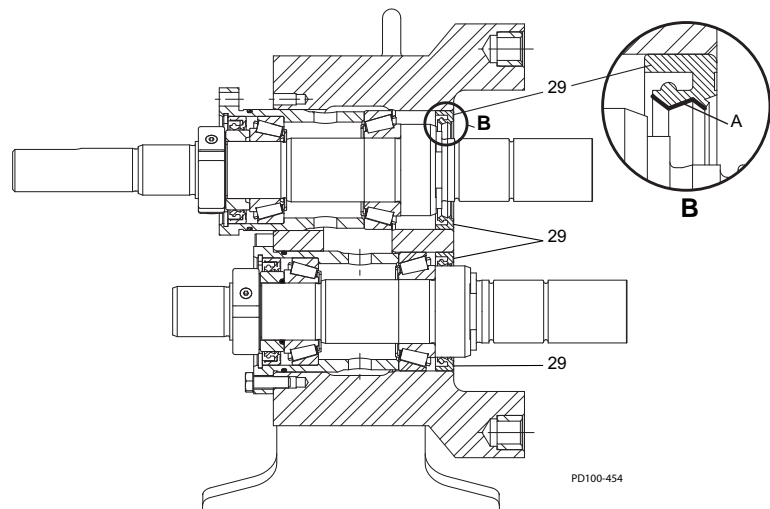

Figure 48 - Apply bearing grease

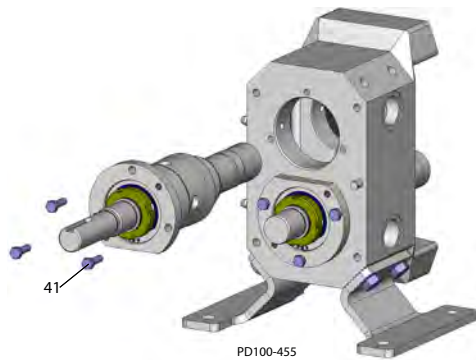

Figure 49 - Secure with cap screws

2. Install the shaft assemblies into the gear case and secure them with cap screws (Figure 49, item 41). Apply a light film of bearing grease to the bores and bearing cups to ease installation. Use care to prevent damage to the lip seals (Figure 48, item 29) during assembly.
3. Install one lug screw (Figure 50, item 4) into one of the tapped holes in each of the shafts and check the rolling torque of each shaft assembly with a torque wrench.

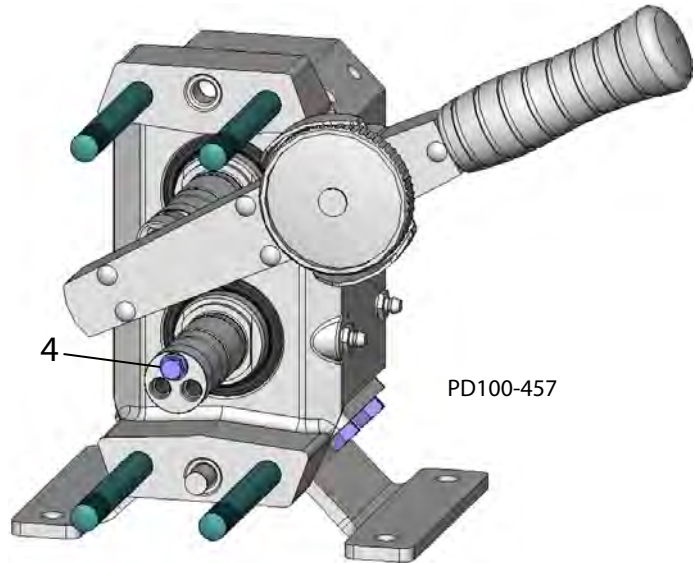

Figure 50 - Check Rolling Torque

4. Tighten or loosen the bearing lock nut (Figure 51, item 20) to achieve a torque value as shown in Table 6.

Table 6: Bearing Rolling Torque

Pump	Torque
0040, 0100, 0140, 0230, 0300	1.6 - 1.8 N-m
0670, 0940	3.2 - 3.4 N-m
2290, 3450	4.5 - 4.7 N-m

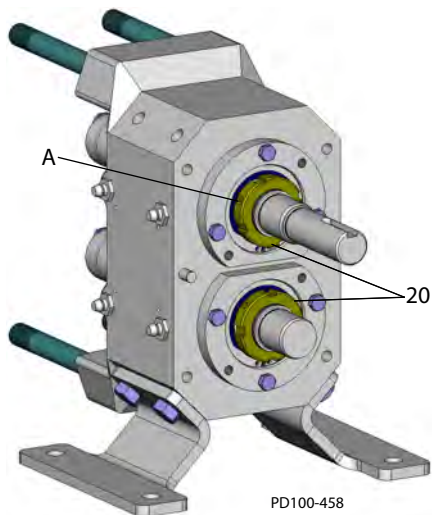

Figure 51 - Tighten Setscrews

5. Tighten the locking setscrew(s) (Figure 51, item A) in the bearing lock nuts (item 20).

Shaft Seal Installation

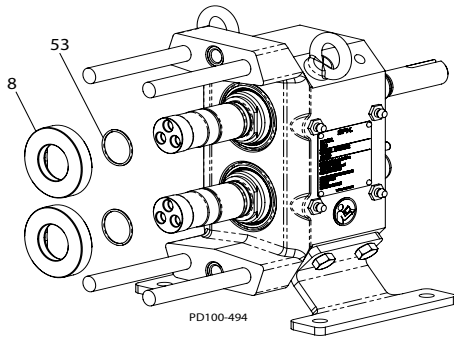

Figure 52 - Shaft Seat Installation

1. Install the seat o-rings (Figure 52, item 53) into the rear groove in the shaft.
2. Apply a compatible lubricant to the o-rings and install the seal seats (Figure 52, item 8). Align the flats in the seal seats with the flats on the shafts and seat them firmly against the shaft shoulder.

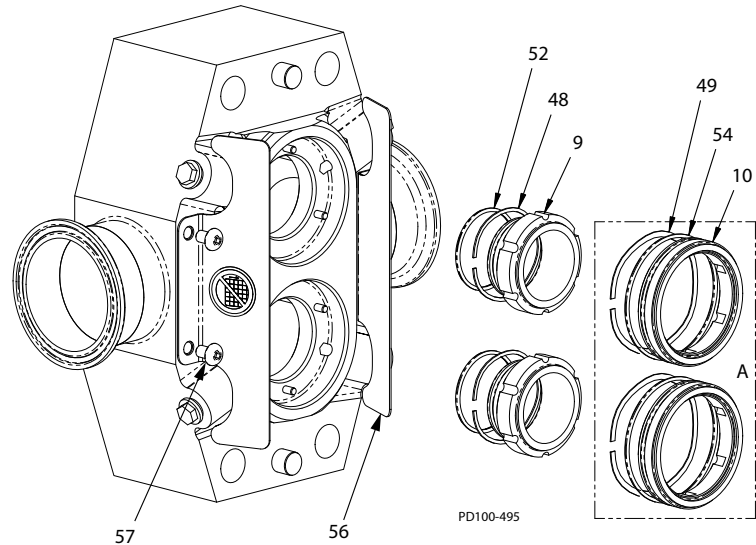

Figure 53 - Shaft Seal Installation

3. Install the inner seal o-ring (Figure 53, item 52) into the inner seal groove and install the wave spring (item 48) onto the body of the inner seals (item 9).
4. Apply a compatible lubricant to the o-rings and install the seal, o-ring, and wave spring into the body. Align the slots in the seal with pins in the body. Repeat for the second seal.
5. Fasten the guards (Figure 53, item 56) to the body with button head screws (item 57).
6. For pumps equipped with double seals (Figure 53, inset A):

Install the outer seal o-ring (Figure 53, item 54) into the groove in the outer seal (item 10).

Place the wave spring (item 49) into the bore, then apply a compatible lubricant to the o-ring and install the seal into the body. Repeat for the second seal.

Mechanical seal guidelines/notes

1. The lapped faces of mechanical seal components are extremely flat and smooth. Use great care when handling these components to prevent damage and reduced seal performance.
2. Although it is impossible to prevent touching the seal faces during assembly, use clean hands and try to minimize contact with the lapped faces.
3. Keep the work area clean to prevent contamination of the seal faces.
4. O-ring lubrication is important to ease assembly of the components, prevent o-ring damage, and provide proper seal function. The lubricant chosen must be non-toxic and compatible with the o-ring material.
5. Clean water can be used as an assembly lubricant for the o-rings if no other lubricant is available.
6. Seal seats should sit squarely against the shaft shoulder.
7. The inner and outer seals should not bind in their respective bores. When pushed by hand, the wave springs should return the seals to their starting position.

Table 7: Cover Spacer Dimensions

Pump	I.D. (mm)	O.D. (mm)	Length (mm)
0040 0100 0140 0230 0300	14	25	18
0670 0940	18	25	18
2290 3450	21	30	30

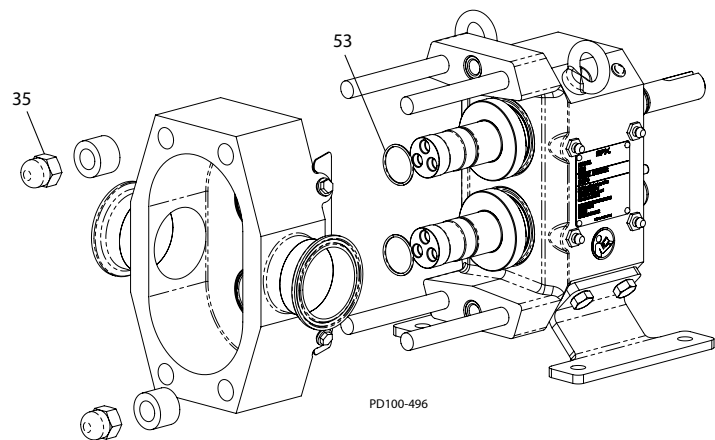

Figure 54 - Body Installation

1. Install the rotor hub seal o-rings (Figure 54, item 53) into the groove of each shaft.
2. Guide the body with seals installed over the studs and seat it firmly to the gear case. Use care to prevent damage to the seals.
3. Fix the body to the gear case using two spacers and acorn nuts (item 35) at opposite corners of the body. See Table 7 for nominal dimensions required for spacers.

NOTE: The screw holes in the rotors are designed to match the screw holes in the shafts in only one orientation. To aid assembly, reference marks are provided on each rotor and the end of the shaft.

Rotor Positioning

Rotor clearances and synchronization require that each rotor must always be installed on a specific shaft to maintain these clearances and prevent pump damage. The drive shaft rotor, therefore, is marked with an 'X' in the lug screw counterbore. The marked rotor must always be installed on the drive shaft.

Rotor Installation

1. The shaft bore of the rotors (Figure 55, item 3) must be clean and free of burrs and debris (Figure 55, item B). The edge chamfer (item C) must be free of burrs to prevent damage to the o-rings.
2. The face of the shaft must be free of raised edges or burrs (see Figure 56, Detail G, item D).
3. **Re-using rotors:** Apply a compatible lubricant to the o-rings and install the marked rotor onto the drive shaft and the unmarked rotor onto the short shaft, making note of the alignment reference mark on the shafts for rotor positioning. (See item A in Figure 56, Detail F and G.)

Installing new rotors: Apply a compatible lubricant to the o-rings and install the rotors onto the shafts, making note of the alignment reference mark on the shafts for rotor positioning. (See item A in Figure 56, Detail F and G.) Stamp an "X" approximately 3mm high in the face of the counterbore opposite the alignment reference mark. See Figure 56, Detail F; also see Figure 31 on page 25 for a larger view.

4. Install one lug screw (Figure 56, item 4) into the hole nearest the reference mark in each rotor.
5. Install the remaining screws and torque all screws to the value listed in Table 8.

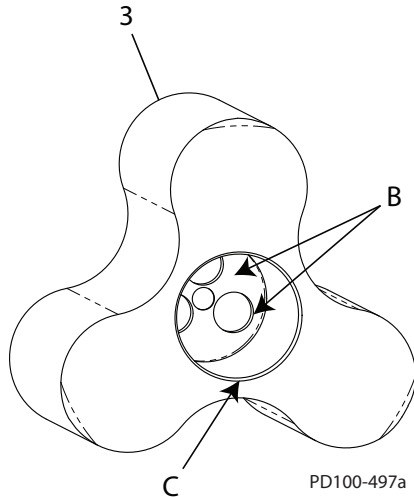

Figure 55 - Rotor Detail

Table 8: Lug Screw Torque

Pump	Hex	Torque
0040 0100 0140 0230 0300	9 mm	24 N-m
0670 0940	13 mm	70 N-m
2290 3450	18 mm	160 N-m

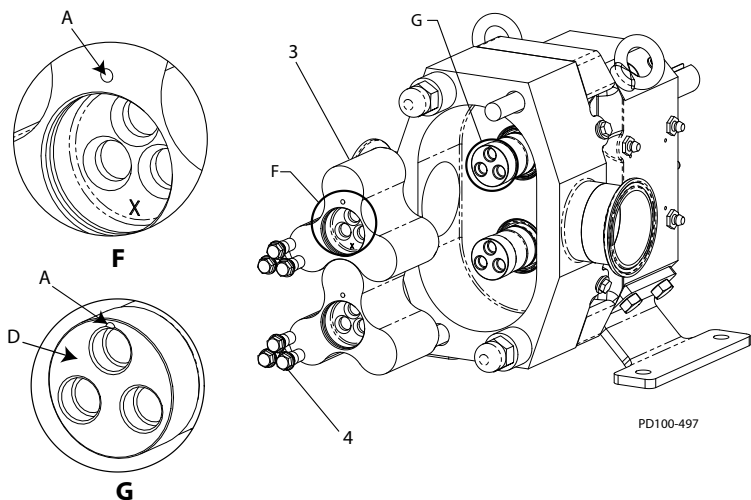

Figure 56 - Rotor Installation

Setting Rotor Clearance

Table 9: Backface and Front Face Clearance

Pump Model	Clearance Target	Acceptable Range	
		Back-face	Front Face
0040 0100 0140	0.100	0.125 0.100	0.260 0.155
0230	0.125	0.150 0.125	0.265 0.160
0300	0.125	0.150 0.125	0.315 0.210
0670 0940	0.150	0.175 0.150	0.340 0.235
2290 3450	0.200	0.225 0.200	0.440 0.335

1. Measure the clearance between the rotor and body as shown in Detail E, item A in Figure 57. Record this number.

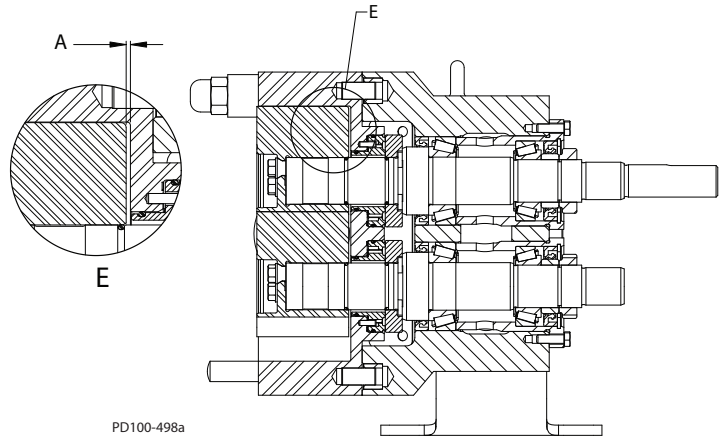

Figure 57 - Rotor to Body Clearance

2. Refer to Table 9. Subtract the "Clearance Target" for the appropriate model from the clearance measurement. The resulting value is the total shim thickness that must be installed behind the flange of the bearing case.
3. Choose a combination of shims (Figure 58, item 15) to achieve a thickness as close as possible to the calculated amount. Do not exceed the calculated amount.
4. Remove the bearing case screws (Figure 58, item 41), install the shims selected in Step 3, and re-install the screws. To provide clearance for the shims, move the shaft toward the rear by tapping gently on the rotor with a soft-faced mallet or by installing two screws in the jacking holes (item P) in the bearing case flange (item 14).
5. Check the resulting backface and front face clearance (items M and N in Figure 59). Adjust the shims as necessary.

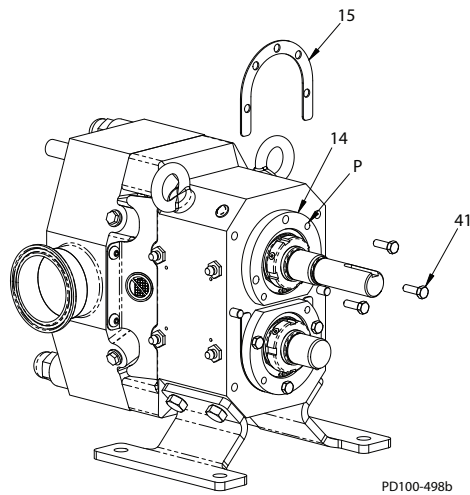

Figure 58 - Install Shims

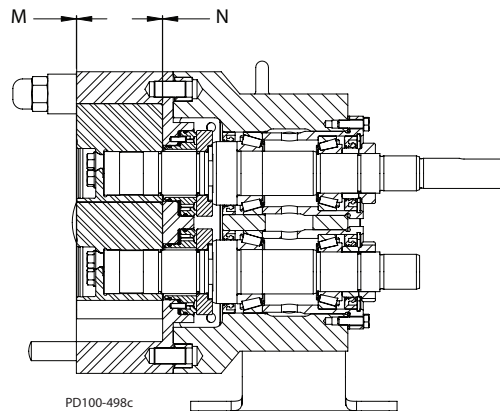

Figure 59 - Measure Clearance

6. Repeat steps 1-5 for the other shaft.

Gear Mounting and Rotor Synchronization

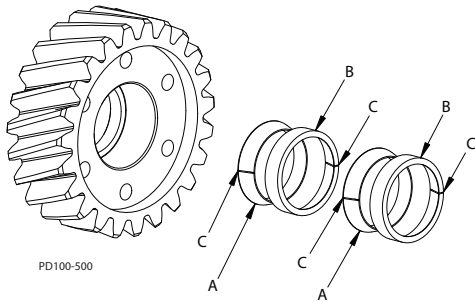

Figure 60 - Locking Element Assembly

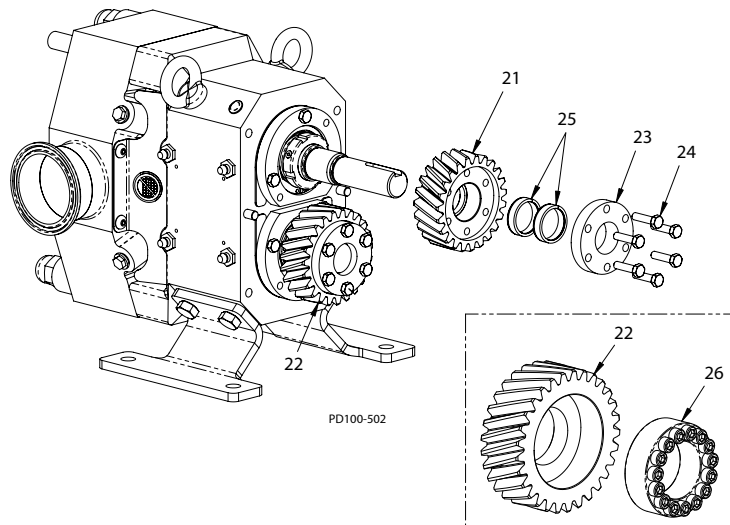
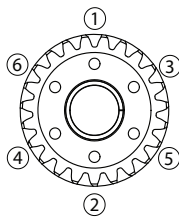
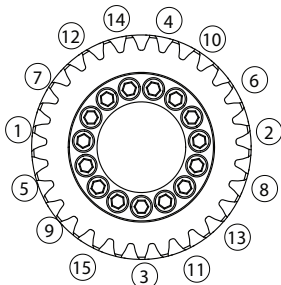

Figure 61 - Gear Mounting



0040-0300



0670-0940

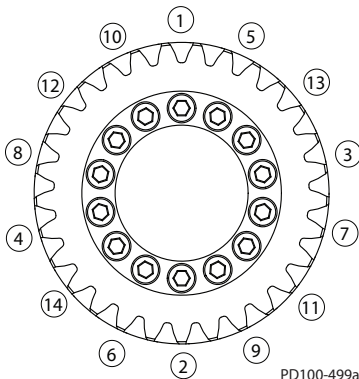

2290-3450

Figure 62 - Screw Tightening Patterns

1. All contact surfaces of the screws, locking elements, gears, and shafts must be clean and slightly oiled with a light lubricant. Do not use oils containing molybdenum disulfide (MoS₂).
2. Assemble the gear (Figure 61, item 22) and locking components onto the lay shaft.
 - For models 0100 - 0300, this refers to the locking elements (Figure 61, item 25), clamp ring (item 23), and screws (item 24).
 - For models 0670 - 3450, this refers to the locking assembly (Figure 61, item 26 (inset)).
3. The locking elements (Figure 61, item 25, detailed in Figure 60) consist of a slit inner ring and a slit outer ring. For proper performance, the elements must be assembled in the following order: inner ring (A), outer ring (B), inner ring (A), outer ring (B); with the slits in the rings (item C) staggered 180° apart as shown in Figure 60.
4. Tighten the screws evenly by hand.
5. Following a diametrically opposite sequence, tighten the screws to the value shown in Table 10 on page 39 for "Step 1." Do not turn any screw more than 1/4 turn at a time, to ensure that the clamp load is applied evenly. Suggested patterns are provided in Figure 62, listed by model number.
6. Following the same sequence as in Step 4, tighten the screws to the value shown in Table 10 on page 39 under the heading "Final."

Table 10: Screw Torque

Pump Model	Screw Torque	
	Step 1	Final
0040 0100 0140 0230 0300	3 N-m	6 N-m
0670 0940	5 N-m	10 N-m
2290 3450	13 N-m	25 N-m

Table 11: Rotor Clearance

Pump Model	Clearance A and B (mm)	
	Max.	Min.
0040	0.30	0.18
0100 0140	0.33	0.21
0230 0300	0.45	0.25
0670 0940	0.59	0.35
2290 3450	0.71	0.51

7. Re-check each screw one-by-one to ensure that the specified torque value has been reached. The process is complete when no screw moves when torque is applied.
8. Assemble the gear (Figure 61, item 21) and locking components onto the drive shaft.
9. Tighten the screws evenly by hand so that the locking components begin to grip the shaft.
10. Check the rotor-to-rotor clearance at the positions shown in Figure 63.

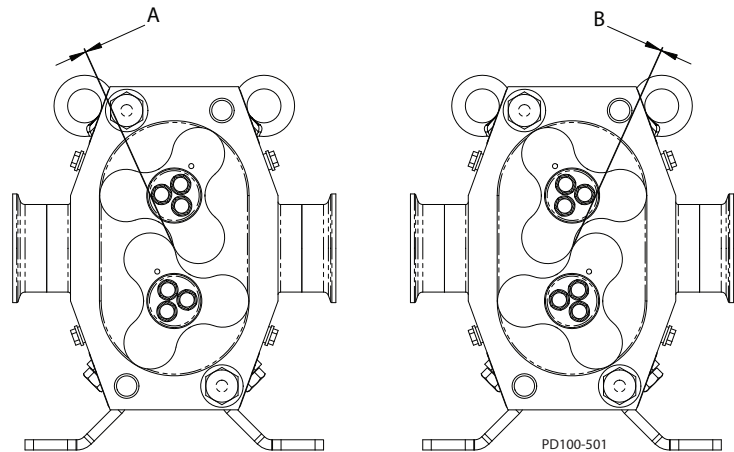

Figure 63 - Rotor Clearance

11. The “A” and “B” clearance dimensions shown in Figure 63 must be within the ranges specified in Table 11 at all positions. Adjust the gear position on the drive shaft as required.
12. Following a diametrically opposite sequence, tighten the screws to the value shown in Table 10 for “Step 1.” Do not turn any screw more than a 1/4 turn at a time to ensure that the clamp load is applied evenly.
13. Following the same sequence as in step 4, tighten the screws to the value shown in Table 10 under the heading “Final.”
14. Re-check each screw one-by-one to ensure that the specified torque value has been reached. The process is complete when no screw moves when torque is applied.

Verify Rotor Clearance

Table 12: Radial Clearance

Pump Model	Radial Clearance (mm)	
	Max.	Min.
0040 0100 0140	0.18	0.11
0230 0300	0.27	0.15
0670 0940	0.39	0.23
2290 3450	0.42	0.25

1. With the rotors synchronized, measure the radial clearance of each lobe (Figure 64, item A) and verify that the clearance falls within the range shown in Table 12.
2. Check clearance at all six points in the body as shown. See Figure 64, item B.

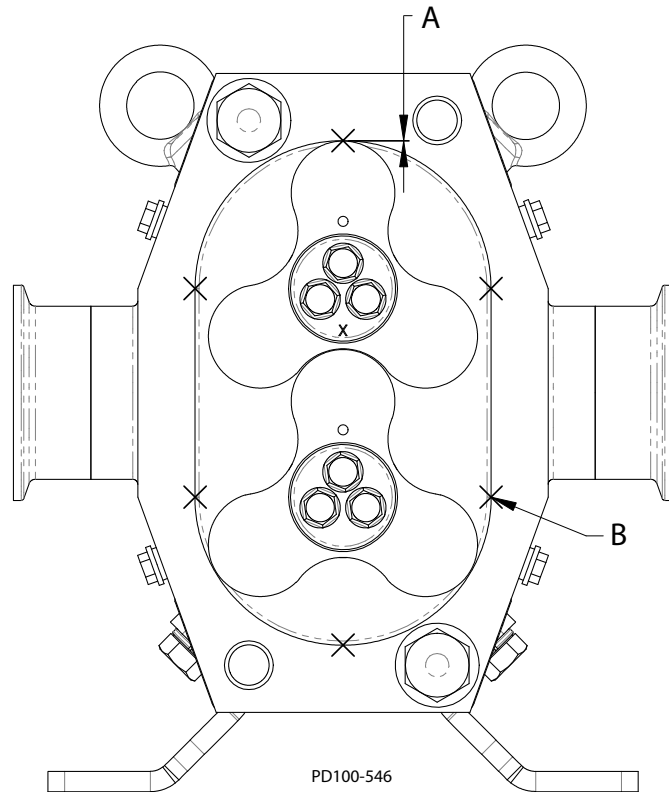

Figure 64 - Radial Clearance Check

Gear Cover Installation

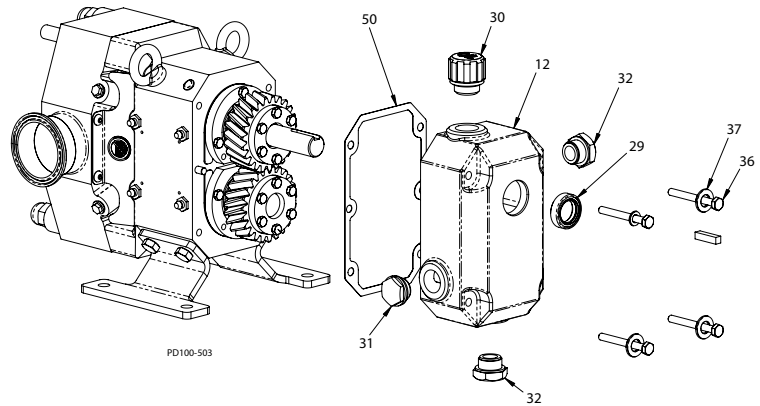

Figure 65 - Gear Cover Installation

Table 13: Oil Volume

Pump Model	Oil Volume (ml)	
	Horizontal Ports	Vertical Ports
0040 0100 0140 0230 0300	100	170
0670 0940	325	490
2290 3450	625	1125

1. Press the input shaft seal (Figure 65, item 29) into the bore of the gear cover (item 12).
2. Place the gasket (item 50) over the dowel pins in the gear case.
3. Lubricate the inside diameter of the seal with bearing grease and install the gear cover. Use care to prevent damage to the lip seal when installing the cover.
4. Install the cap screws (item 36) and washers (item 37) and tighten them evenly.
5. Install the oil plugs (item 32) and level indicator plug (item 31) into the appropriate locations for the pump mounting position.
6. Fill with oil and install the breather plug (item 30). Table 13 provides oil capacity by pump size and mounting position. The oil level should reach the center of the level indicator.
7. Grease the bearings. See Table 14 for the approximate volume of grease required for the initial charge. For re-greasing a pump in service, see Table 3 on page 22.

Table 14: Grease Volume

Pump Model	Grease Volume (ml)	
	Front Bearing	Rear Bearing
0040 0100 0140 0230 0300	8.7	8.2
0670 0940	16.6	17.1
2290 3450	43.2	39.6

Cover Installation

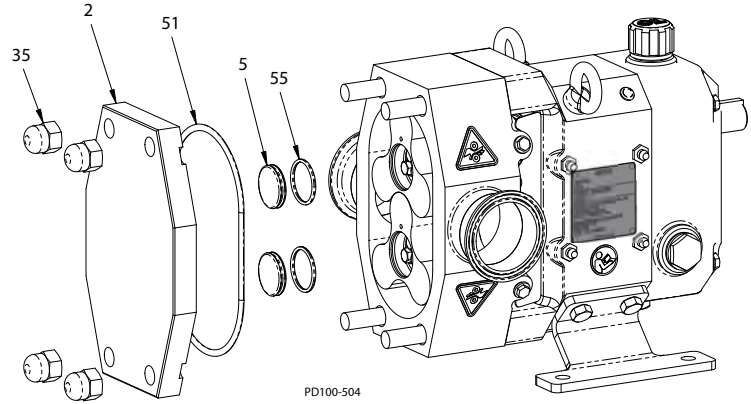

Figure 66 - Cover Installation

1. Install the screw cap o-ring (Figure 66, item 55) into the groove in the screw cap (item 5) and install it in the rotor bore. The o-ring snaps into the groove in the rotor bore.
2. Install the cover o-ring (item 51) into the groove in the cover.
3. Remove the acorn nuts and spacers used to secure the pump body.
4. Install the cover (item 2) over the studs and fasten it securely with acorn nuts (item 35). The pump should rotate freely by hand with no binding or dragging.
5. Check that all labels are in place and legible. See "Replacement Labels" on page 7.

Torque Reference

Table 15: Nut and Screw Torque Reference

Model	Rotor Lug Screw		Cover Nut		Bearing Nut Lock Screw		Gear Locking Assembly	
	Hex	Torque	Hex	Torque	Hex	Torque	Hex	Torque
0040 0100 0140 0230 0300	9 mm	24 N-m 17 lb-ft	19 mm	71 N-m 52 lb-ft	2.5 mm	4 N-m 35 lb-in	8 mm	6 N-m
0670 0940	13 mm	70 N-m 52 lb-ft	24 mm	172 N-m 127 lb-ft	3 mm	8 N-m 70 lb-in	5 mm	10 N-m
2290 3450	18 mm	160 N-m 118 lb-ft	30 mm	347 N-m 256 lb-ft	3 mm	8 N-m 70 lb-in	6 mm	25 N-m

Troubleshooting

PROBLEM	POSSIBLE CAUSE	SUGGESTED ACTION
No flow, pump rotors are not turning.	Drive motor not running.	Check resets, fuses, circuit breakers.
	Keys sheared or missing.	Replace.
	Drive belts, power transmission components slipping or broken.	Replace or adjust.
	Pump shaft, keys, or gears sheared.	Inspect: and replace parts as necessary.
No flow, pump rotors are turning.	Rotors turn in the wrong direction.	Check motor hookup to reverse motor rotation.
	Relief valve not properly adjusted, or held open by foreign material.	Adjust or clear valve.
No flow, pump not priming.	Valve closed in inlet line.	Open valve.
	Inlet line clogged or restricted.	Clear line, clean filters, etc.
	Air leaks due to bad gaskets or pipe connections.	Replace gaskets; check lines for leakage (can be done by air, by pressure or by filling with liquid and pressurizing with air).
	Pump speed too slow.	Increase pump speed.
	Liquid drains or siphons from system during off periods.	Use foot valve or check valves. Filling inlet lines with material before startup may solve startup priming problems due to no material in system.
	"Air" lock caused by fluids which "gas off", or vaporize, or allow gas to come out of solution during off periods.	Install and use a manual or automatic air bleed from pump or lines near pump.
	Extra clearance rotors, worn pump.	Increase pump speed, use foot valve to improve priming.
	Net inlet pressure available too low.	Check Net Inlet Pressure Available & Net Inlet Pressure Required. Change inlet system as needed.
On "Vacuum" inlet system: On initial start-up, atmospheric "blow back" prevents pump from developing enough differential pressure to start flow.	Install check valve in discharge line.	

PROBLEM	POSSIBLE CAUSE	SUGGESTED ACTION
Insufficient flow.	Speed too low to obtain desired flow.	Check flow-speed curve (available from customer service) and adjust as necessary.
	Air leak due to bad seals, gadgets or pipe connections.	Replace seals, check inlet fittings.
Fluid vaporization ("starved" pump inlet).	Strainers, foot valves, inlet fittings or lines clogged.	Clear lines. If problem continues, inlet system may require changing.
	Inlet line size too small, inlet line too long. Too many fittings or valves. Foot valve, strainers too small.	Increase inlet line size. Reduce length, minimize direction and size changes, reduce number of fittings.
	NIPA - Net Inlet Pressure Available at Pump is too low.	Raise liquid level in source tank to increase Net Inlet Pressure (NIPA). Increase Net Inlet Pressure Available at Pump by raising or pressurizing source tank.
	Fluid viscosity greater than expected.	Reduce pump speed and accept lower flow, or change system to reduce line losses. Increase temperature of product to reduce viscosity.
	Fluid temperature higher than expected (vapor pressure higher).	Reduce temperature, reduce speed and accept lower flow or change system to increase Net Inlet Pressure Available.
Insufficient flow. Flow being bypassed somewhere.	Flow diverted in branch line, open valve, etc.	Check system and controls
	Relief valve not adjusted or jammed.	Clear or adjust valve.
Insufficient flow. High slip.	Hot (HC) or extra clearance rotors on "cold" fluid, and/or low viscosity fluid.	Replace with standard clearance rotors.
	Worn pump.	Increase pump speed (within limits). Replace rotors, have pump remanufactured.
	High pressure.	Reduce pressure by adjusting system settings or hardware.

PROBLEM	POSSIBLE CAUSE	SUGGESTED ACTION
Noisy operation caused by fluid.	Cavitation due to high fluid viscosity. High vapor pressure fluid. High temperature.	Slow down pump, reduce temperature, change system setup.
	Cavitation due to Net Inlet Pressure Available less than Net Inlet Pressure Required Net Inlet Pressure Required.	Increase NIPA - Net Inlet Pressure Required or reduce NIPR - Net Inlet Pressure Required. Contact customer service if necessary.
	Air or gas in fluid caused by leaks in the piping.	Check system and fix any leaks.
	Air or gas in fluid caused by dissolved gas or naturally aerated products.	Minimize discharge pressure (also see Cavitation).
Noisy operation caused by mechanical problems.	Rotor to body contact due to improper assembly of pump.	Check clearances and adjust shimming.
	Rotor to body contact caused by distortion of pump due to improper piping installation.	Change piping installation to eliminate piping stress and distortion on body.
	Pressures required higher than the pump is rated for.	Reduce discharge pressure required.
	Rotor to body contact caused by worn bearings.	Rebuild with new bearings and lubricate regularly.
	Rotor to Rotor Contact caused by loose or not timed correctly gears.	This has caused severe damage to components - rebuild with new parts.
	Rotor to Rotor Contact caused by sheared keys.	This has caused severe damage to components - rebuild with new parts.
	Rotor to Rotor Contact caused by worn gear splines.	This has caused severe damage to components - rebuild with new parts.
Drive noise caused by gear trains, chains, couplings, bearings.	Repair or replace drive parts. Check bearings for damage and replace as necessary.	

PROBLEM	POSSIBLE CAUSE	SUGGESTED ACTION
Pump requires excessive power (over heats, stalls, high current draw, breakers trip).	Higher than expected viscosity losses.	If within pump rating, increase drive size.
	Higher than expected pressures.	Reduce pump speed. Increase line sizes.
	Fluid is colder with a higher viscosity than expected.	Heat fluid, insulate lines or heat trace lines.
	Fluid sets in line and pump during shutdown.	Increase line sizes. Insulate lines or heat trace lines.
	Fluid builds up on pump surfaces.	Install a “soft start” drive. Install a recirculating bypass system. Flush system with a nonsetting fluid.
Short pump service life.	Pumping abrasives	Larger pumps at slower speeds.
	Speeds and pressures higher than rated.	Reduce speeds and pressures by making changes in the system. Replace pump with a large model with higher pressure ratings.
	Worn bearings and gears due to lack of lubrication.	Check and replace bearing and gears as necessary. Adjust lubrication schedule to decrease time between lubrication.
	Misalignment of drive and piping. (Excessive over hung load or misaligned couplings).	Check alignment of piping and drive. Adjust as necessary.

Notes

Parts Lists

Model 0040-0300 Pump Parts

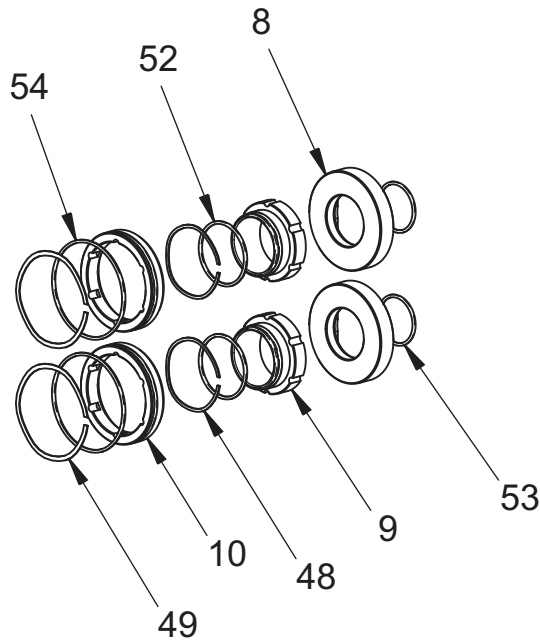
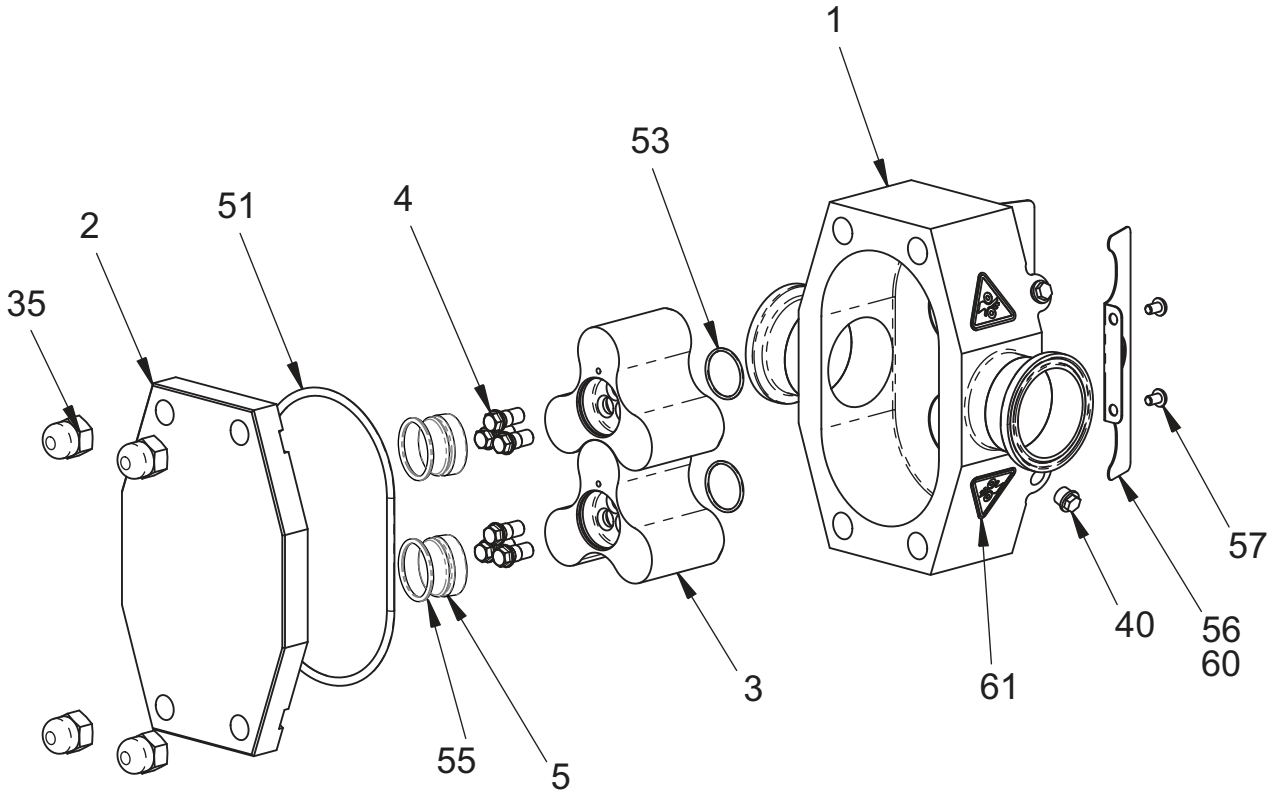

PD100-505

Model 0040 - 0300 Pump Parts

ITEM	DESCRIPTION	QTY	PART NUMBER BY MODEL					NOTES
			0040	0100	0140	0230	0300	
1	FINISHED BODY ASSEMBLY - S-LINE	1	CNG127255	CNG127256	CNG127257	CNG127258	CNG127259	
	FINISHED BODY ASSEMBLY - DIN		CNG127264	CNG127265	CNG127266	CNG127267	CNG127268	
	FINISHED BODY ASSEMBLY - ISO 2633 FLG		CNG127933	CNG127934	CNG127935	CNG127936	CNG127937	
2	COVER	1	CNG127172	CNG127173	CNG127173	CNG127174	CNG127174	
3	ROTOR	2	CNG127407	CNG127408	CNG127409	CNG127410	CNG127411	
4	ROTOR LUG SCREW	6	CNG127416	CNG127416	CNG127416	CNG127416	CNG127416	
5	COVER-ROTOR SCREW	2	CNG127944	CNG127944	CNG127944	CNG127944	CNG127944	
8	SEAL SEAT - STAINLESS STEEL	2	CNG127207	CNG127207	CNG127207	CNG127207	CNG127207	
	SEAL SEAT - SILICON CARBIDE	2	CNG127210	CNG127210	CNG127210	CNG127210	CNG127210	
9	INNER SEAL - CARBON	2	CNG127610	CNG127610	CNG127610	CNG127610	CNG127610	
	INNER SEAL - SILICON CARBIDE	2	CNG127216	CNG127216	CNG127216	CNG127216	CNG127216	
10	OUTER SEAL - CARBON	2	CNG127613	CNG127613	CNG127613	CNG127613	CNG127613	
35	ACORN NUT	4	CNG127285	CNG127285	CNG127285	CNG127285	CNG127285	
40	PLUG 1/8 BSP POLY (FLUSH PORTS)	4	CNG127484	CNG127484	CNG127484	CNG127484	CNG127484	
48	WAVE SPRING - INNER SEAL	2	CNG127222	CNG127222	CNG127222	CNG127222	CNG127222	
49	WAVE SPRING - OUTER SEAL	2	CNG127225	CNG127225	CNG127225	CNG127225	CNG127225	
51	O-RING - COVER FKM	1	CNG127432	CNG127434	CNG127434	CNG127436	CNG127436	1
	O-RING - COVER EPDM	1	CNG127433	CNG127435	CNG127435	CNG127437	CNG127437	1
52	O-RING - INNER SEAL FKM	2	CNG127454	CNG127454	CNG127454	CNG127454	CNG127454	1
	O-RING - INNER SEAL EPDM	2	CNG127455	CNG127455	CNG127455	CNG127455	CNG127455	1
53	O-RING - SEAL SEAT/ROTOR HUB FKM	4	CNG127448	CNG127448	CNG127448	CNG127448	CNG127448	1
	O-RING - SEAL SEAT/ROTOR HUB EPDM	4	CNG127449	CNG127449	CNG127449	CNG127449	CNG127449	1
54	O-RING - OUTER SEAL FKM	2	CNG127456	CNG127456	CNG127456	CNG127456	CNG127456	1
	O-RING - OUTER SEAL EPDM	2	CNG127457	CNG127457	CNG127457	CNG127457	CNG127457	1
55	O-RING - ROTOR SCREW COVER FKM	2	CNG127442	CNG127442	CNG127442	CNG127442	CNG127442	1
	O-RING - ROTOR SCREW COVER EPDM	2	CNG127443	CNG127443	CNG127443	CNG127443	CNG127443	1
56	GUARD - SHAFT SEAL	2	CNG127381	CNG127381	CNG127381	CNG127381	CNG127381	
57	BHCS-M5X8 18-8 SS	4	CNG127384	CNG127384	CNG127384	CNG127384	CNG127384	
60	LABEL - ISO GUARD	2	CNG127388	CNG127388	CNG127388	CNG127388	CNG127388	
61	LABEL - ISO ENTANGLEMENT HAZARD	4	CNG127387	CNG127387	CNG127387	CNG127387	CNG127387	

Notes

1. FKM is standard; EPDM is optional

PL8010-CH2

Model 0040-0300 Pump Parts

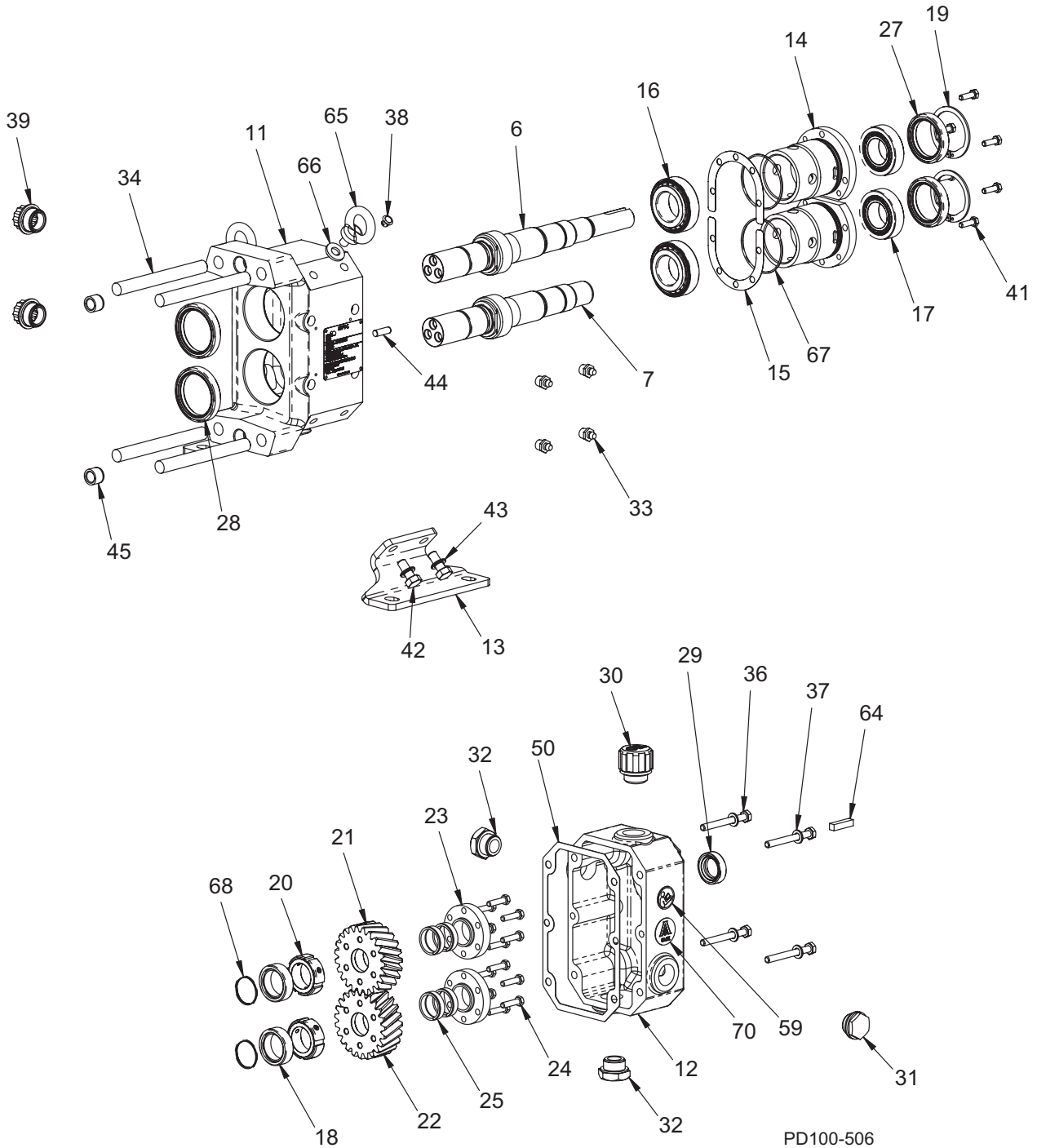

PD100-506

Model 0040-0300 Pump Parts

ITEM	DESCRIPTION	QTY	PART NUMBER BY MODEL					NOTES
			0040	0100	0140	0230	0300	
6	DRIVE SHAFT	1	CNG127389	CNG127391	CNG127393	CNG127395	CNG127397	
7	LAY SHAFT	1	CNG127390	CNG127392	CNG127394	CNG127396	CNG127398	
11	BEARING HOUSING (GEARCASE)	1	CNG127160	CNG127160	CNG127160	CNG127160	CNG127160	
12	GEAR COVER	1	CNG127166	CNG127166	CNG127166	CNG127166	CNG127166	
13	MOUNTING FOOT	2	CNG127201	CNG127201	CNG127201	CNG127201	CNG127201	
14	BEARING CASE	2	CNG127180	CNG127180	CNG127180	CNG127180	CNG127180	
15	SHIM-AXIAL POSITIONING-0.025	A/R	CNG127504	CNG127504	CNG127504	CNG127504	CNG127504	
	SHIM-AXIAL POSITIONING-0.05		CNG127426	CNG127426	CNG127426	CNG127426	CNG127426	
	SHIM-AXIAL POSITIONING-0.10		CNG127427	CNG127427	CNG127427	CNG127427	CNG127427	
	SHIM-AXIAL POSITIONING-1.0		CNG127505	CNG127505	CNG127505	CNG127505	CNG127505	
16	FRONT BEARING	2	CNG127288	CNG127288	CNG127288	CNG127288	CNG127288	
17	REAR BEARING	2	CNG127291	CNG127291	CNG127291	CNG127291	CNG127291	
18	SEAL SLEEVE	2	CNG127198	CNG127198	CNG127198	CNG127198	CNG127198	
19	RETAINING RING - REAR BEARING SEAL	2	CNG127319	CNG127319	CNG127319	CNG127319	CNG127319	
20	BEARING LOCK NUT	2	CNG127586	CNG127586	CNG127586	CNG127586	CNG127586	
21	HELICAL GEAR RH	1	CNG127137	CNG127137	CNG127137	CNG127137	CNG127137	
22	HELICAL GEAR LH	1	CNG127138	CNG127138	CNG127138	CNG127138	CNG127138	
23	CLAMP RING - GEAR	2	CNG127526	CNG127526	CNG127526	CNG127526	CNG127526	
24	HHCS - CLAMP PLATE	12	CNG127528	CNG127528	CNG127528	CNG127528	CNG127528	
25	LOCKING ELEMENT	4	CNG127527	CNG127527	CNG127527	CNG127527	CNG127527	
27	SEAL - REAR BEARING	2	CNG127306	CNG127306	CNG127306	CNG127306	CNG127306	
28	SEAL - FRONT BEARING	2	CNG127303	CNG127303	CNG127303	CNG127303	CNG127303	
29	SEAL - INPUT SHAFT	1	CNG127309	CNG127309	CNG127309	CNG127309	CNG127309	
30	BREATHER PLUG	1	CNG127314	CNG127314	CNG127314	CNG127314	CNG127314	
31	LEVEL INDICATOR PLUG	1	CNG127315	CNG127315	CNG127315	CNG127315	CNG127315	
32	OIL PLUG	2	CNG127313	CNG127313	CNG127313	CNG127313	CNG127313	
33	GREASE FITTING-G1/8 BSPT	4	CNG127312	CNG127312	CNG127312	CNG127312	CNG127312	
34	COVER STUD	4	CNG127183	CNG127184	CNG127185	CNG127185	CNG127186	
36	HHCS - GEAR COVER	4	CNG127475	CNG127475	CNG127475	CNG127475	CNG127475	
37	WASHER - GEAR COVER	4	CNG127480	CNG127480	CNG127480	CNG127480	CNG127480	
38	PLUG - TAPPED HOLE	4	CNG127379	CNG127379	CNG127379	CNG127379	CNG127379	
39	PLASTIC PLUG - GREASE CLEANOUT	2	CNG127483	CNG127483	CNG127483	CNG127483	CNG127483	
41	HHCS - BEARING CASE	6	CNG127472	CNG127472	CNG127472	CNG127472	CNG127472	
42	HHCS - MOUNTING FOOT	4	CNG127478	CNG127478	CNG127478	CNG127478	CNG127478	
44	DOWEL PIN-M6X18	2	CNG127377	CNG127377	CNG127377	CNG127377	CNG127377	
45	DOWEL BUSHING - G SERIES	2	CNG127376	CNG127376	CNG127376	CNG127376	CNG127376	
46	DOWEL PIN-M10X20 (not shown)	2	CNG127378	CNG127378	CNG127378	CNG127378	CNG127378	
47	DOWEL PIN - (SEAL STOP PIN) (not shown)	6	CNG127282	CNG127282	CNG127282	CNG127282	CNG127282	
50	GEAR COVER GASKET	1	CNG127204	CNG127204	CNG127204	CNG127204	CNG127204	
59	LABEL - ISO READ MANUAL	1	CNG127385	CNG127385	CNG127385	CNG127385	CNG127385	
64	KEY- INPUT SHAFT	1	CNG127316	CNG127316	CNG127316	CNG127316	CNG127316	
65	EYEBOLT	2	CNG127487	CNG127487	CNG127487	CNG127487	CNG127487	
66	EYEBOLT WASHER - RUBBER	2	CNG127510	CNG127510	CNG127510	CNG127510	CNG127510	
67	O-RING - BEARING CASE BUNA N	2	CNG127580	CNG127580	CNG127580	CNG127580	CNG127580	
68	O-RING - SEAL SLEEVE BUNA N	2	CNG127583	CNG127583	CNG127583	CNG127583	CNG127583	
70	LABEL - 3-A	1	125096+	125096+	125096+	125096+	125096+	

PL8010-CH4

Model 0670-3450 Pump Parts

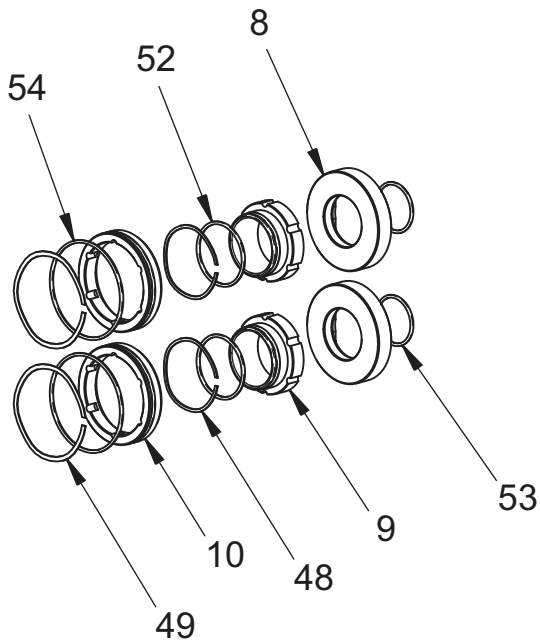
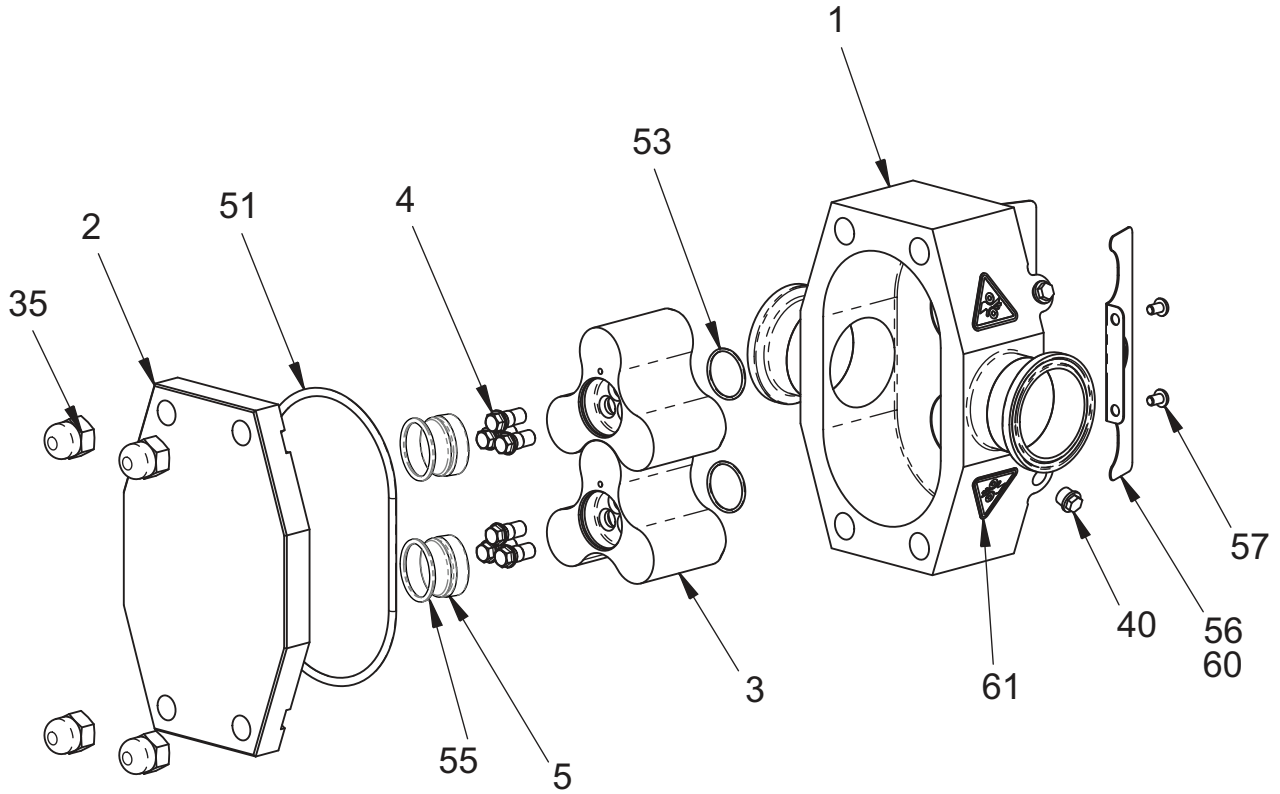

PD100-505

Model 0670-3450 Pump Parts

ITEM	DESCRIPTION	QTY	PART NUMBER BY MODEL				NOTES
			0670	0940	2290	3450	
1	FINISHED BODY ASSEMBLY - S-LINE	1	CNG127260	CNG127261	CNG127262	CNG127263	
	FINISHED BODY ASSEMBLY - DIN		CNG127269	CNG127270	CNG127271	CNG127272	
	FINISHED BODY ASSEMBLY - ISO 2633 FLG		CNG127938	CNG127939	CNG127940	CNG127941	
2	COVER	1	CNG127175	CNG127175	CNG127176	CNG127176	
3	ROTOR	2	CNG127412	CNG127413	CNG127414	CNG127415	
4	ROTOR LUG SCREW	6	CNG127417	CNG127417	CNG127418	CNG127418	
5	COVER-ROTOR SCREW	2	CNG127945	CNG127945	CNG127946	CNG127946	
8	SEAL SEAT - STAINLESS STEEL	2	CNG127208	CNG127208	CNG127209	CNG127209	
	SEAL SEAT - SILICON CARBIDE	2	CNG127211	CNG127211	CNG127212	CNG127212	
9	INNER SEAL - CARBON	2	CNG127611	CNG127611	CNG127612	CNG127612	
	INNER SEAL - SILICON CARBIDE	2	CNG127217	CNG127217	CNG127218	CNG127218	
10	OUTER SEAL - CARBON	2	CNG127614	CNG127614	CNG127615	CNG127615	
35	ACORN NUT	4	CNG127286	CNG127286	CNG127287	CNG127287	
40	PLUG 1/8 BSP POLY (FLUSH PORTS)	4	CNG127484	CNG127484	CNG127484	CNG127484	
48	WAVE SPRING - INNER SEAL	2	CNG127223	CNG127223	CNG127224	CNG127224	
49	WAVE SPRING - OUTER SEAL	2	CNG127226	CNG127226	CNG127227	CNG127227	
51	O-RING - COVER FKM	1	CNG127438	CNG127438	CNG127440	CNG127440	1
	O-RING - COVER EPDM	1	CNG127439	CNG127439	CNG127441	CNG127441	1
52	O-RING - INNER SEAL FKM	2	CNG127460	CNG127460	CNG127458	CNG127458	1
	O-RING - INNER SEAL EPDM	2	CNG127461	CNG127461	CNG127459	CNG127459	1
53	O-RING - SEAL SEAT/ROTOR HUB FKM	4	CNG127450	CNG127450	CNG127452	CNG127452	1
	O-RING - SEAL SEAT/ROTOR HUB EPDM	4	CNG127451	CNG127451	CNG127453	CNG127453	1
54	O-RING - OUTER SEAL FKM	2	CNG127462	CNG127462	CNG127464	CNG127464	1
	O-RING - OUTER SEAL EPDM	2	CNG127463	CNG127463	CNG127465	CNG127465	1
55	O-RING - ROTOR SCREW COVER FKM	2	CNG127450	CNG127450	CNG127446	CNG127446	1
	O-RING - ROTOR SCREW COVER EPDM	2	CNG127451	CNG127451	CNG127447	CNG127447	1
56	GUARD - SHAFT SEAL	2	CNG127382	CNG127382	CNG127383	CNG127383	
57	BHCS-M5X8 18-8 SS	4	CNG127384	CNG127384	CNG127384	CNG127384	
60	LABEL - ISO GUARD	2	CNG127388	CNG127388	CNG127388	CNG127388	
61	LABEL - ISO ENTANGLEMENT HAZARD	4	CNG127387	CNG127387	CNG127387	CNG127387	

Notes

- FKM is standard; EPDM is optional

PL8010-CH3

Model 0670-3450 Pump Parts

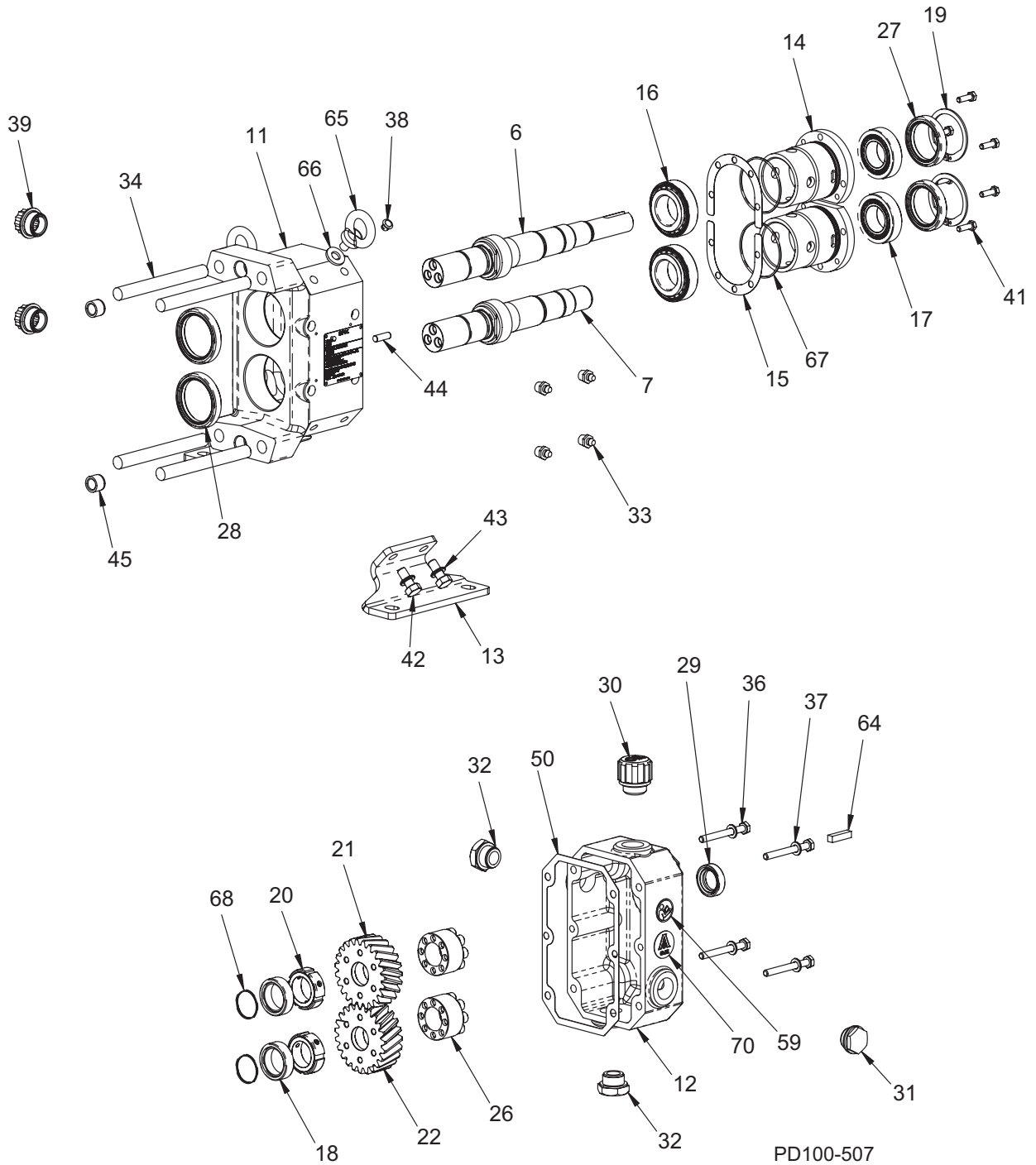

Model 0670-3450 Pump Parts

ITEM	DESCRIPTION	QTY	PART NUMBER BY MODEL				NOTES
			0670	0940	2290	3450	
6	DRIVE SHAFT	1	CNG127399	CNG127401	CNG127403	CNG127405	
7	LAY SHAFT	1	CNG127400	CNG127402	CNG127404	CNG127406	
11	BEARING HOUSING (GEARCASE)	1	CNG127161	CNG127161	CNG127162	CNG127162	
12	GEAR COVER	1	CNG127167	CNG127167	CNG127168	CNG127168	
13	MOUNTING FOOT	2	CNG127202	CNG127202	CNG127203	CNG127203	
14	BEARING CASE	2	CNG127181	CNG127181	CNG127182	CNG127182	
15	SHIM-AXIAL POSITIONING-0.025	A/R	CNG127506	CNG127506	CNG127508	CNG127508	
	SHIM-AXIAL POSITIONING-0.05		CNG127428	CNG127428	CNG127430	CNG127430	
	SHIM-AXIAL POSITIONING-0.10		CNG127429	CNG127429	CNG127431	CNG127431	
	SHIM-AXIAL POSITIONING-1.0		CNG127507	CNG127507	CNG127509	CNG127509	
16	FRONT BEARING	2	CNG127289	CNG127289	CNG127290	CNG127290	
17	REAR BEARING	2	CNG127292	CNG127292	CNG127293	CNG127293	
18	SEAL SLEEVE	2	CNG127199	CNG127199	CNG127200	CNG127200	
19	RETAINING RING - REAR BEARING SEAL	2	CNG127320	CNG127320	CNG127321	CNG127321	
20	BEARING LOCK NUT	2	CNG127587	CNG127587	CNG127588	CNG127588	
21	HELICAL GEAR RH	1	CNG127139	CNG127139	CNG127141	CNG127141	
22	HELICAL GEAR LH	1	CNG127140	CNG127140	CNG127142	CNG127142	
26	LOCKING ASSEMBLY	2	CNG127529	CNG127529	CNG127530	CNG127530	
27	SEAL - REAR BEARING	2	CNG127947	CNG127947	CNG127305	CNG127305	
28	SEAL - FRONT BEARING	2	CNG127304	CNG127304	CNG127305	CNG127305	
29	SEAL - INPUT SHAFT	1	CNG127310	CNG127310	CNG127307	CNG127307	
30	BREATHER PLUG	1	CNG127314	CNG127314	CNG127314	CNG127314	
31	LEVEL INDICATOR PLUG	1	CNG127315	CNG127315	CNG127315	CNG127315	
32	OIL PLUG	2	CNG127313	CNG127313	CNG127313	CNG127313	
33	GREASE FITTING-G1/8 BSPT	4	CNG127312	CNG127312	CNG127312	CNG127312	
34	COVER STUD	4	CNG127187	CNG127188	CNG127189	CNG127190	
36	HHCS - GEAR COVER	4	CNG127476	CNG127476	CNG127477	CNG127477	
37	WASHER - GEAR COVER	4	CNG127481	CNG127481	CNG127482	CNG127482	
38	PLUG - TAPPED HOLE	4	CNG127380	CNG127380	CNG127380	CNG127380	
39	PLASTIC PLUG - GREASE CLEANOUT	2	CNG127483	CNG127483	CNG127483	CNG127483	
41	HHCS - BEARING CASE	6	CNG127473	CNG127473	CNG127474	CNG127474	
42	HHCS - MOUNTING FOOT	4	CNG127479	CNG127479	CNG127479	CNG127479	
44	DOWEL PIN-M6X18	2	CNG127377	CNG127377	CNG127377	CNG127377	
45	DOWEL BUSHING - G SERIES	2	CNG127376	CNG127376	CNG127376	CNG127376	
46	DOWEL PIN-M10X20 (not shown)	2	CNG127378	CNG127378	CNG127378	CNG127378	
47	DOWEL PIN - (SEAL STOP PIN) (not shown)	6	CNG127283	CNG127283	CNG127284	CNG127284	
50	GEAR COVER GASKET	1	CNG127205	CNG127205	CNG127206	CNG127206	
59	LABEL - ISO READ MANUAL	1	CNG127386	CNG127386	CNG127386	CNG127386	
64	KEY- INPUT SHAFT	1	CNG127317	CNG127317	CNG127318	CNG127318	
65	EYEBOLT	2	CNG127488	CNG127488	CNG127488	CNG127488	
66	EYEBOLT WASHER - RUBBER	2	CNG127511	CNG127511	CNG127511	CNG127511	
67	O-RING - BEARING CASE BUNA N	2	CNG127581	CNG127581	CNG127582	CNG127582	
68	O-RING - SEAL SLEEVE BUNA N	2	CNG127584	CNG127584	CNG127585	CNG127585	
70	LABEL - 3-A	1	125096+	125096+	125096+	125096+	

PL8010-CH5

Maintenance Kits

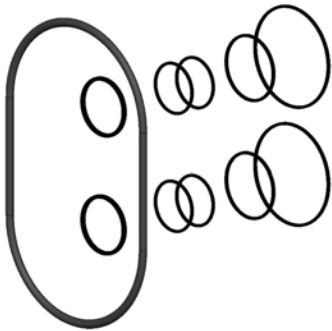

O-Ring Kit



Product Seal Kit



Double Seal Kit

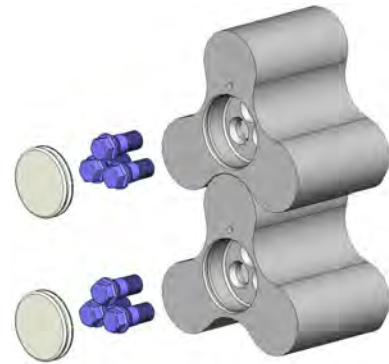

Rotor Replacement Kit

MAINTENANCE KIT INDEX						
MODEL	O-RING		PRODUCT SEAL		DOUBLE SEAL	ROTOR REPLACEMENT
	FKM	EPDM	STANDARD	SC vs. SC		
0040	CNG127334	CNG127335	CNG127498	CNG127495	CNG127492	CNG127364
0100	CNG127336	CNG127337				CNG127365
0140						CNG127366
0230	CNG127338	CNG127339				CNG127367
0300			CNG127368			
0670	CNG127340	CNG127341	CNG127499	CNG1276496	CNG127493	CNG127369
0940						CNG127370
2290	CNG127342	CNG127343	CNG127500	CNG127497	CNG127494	CNG127371
3450						CNG127372

PL8010-CH1

Table 16 - Recommended Maintenance Schedule

Item	Maintenance Interval
Replace Gear Oil	Every 1000 hours. See “Gear Oil” on page 21.
Grease Bearings	Every 250 hours. See “Bearing Lubrication” on page 22.
Replace O-Rings	Every time o-rings are removed.

NOTE: For seals and rotors, component life varies widely between different applications. Inspect for wear and replace as needed. See “Maintenance Inspection Chart” on page 24.

TLP Series

SANITARY POSITIVE DISPLACEMENT
PUMP



SPX FLOW TECHNOLOGY

www.spx.com

SPX reserves the right to incorporate our latest design and material changes without notice or obligation.

Design features, materials of construction and dimensional data, as described in this bulletin, are provided for your information only and should not be relied upon unless confirmed in writing.

Please contact your local sales representative for product availability in your region. For more information visit www.spx.com.

The green ">" is a trademark of SPX Corporation, Inc.

ISSUED: 01/2013

COPYRIGHT © 2009, 2013 SPX Corporation