

VECTOR



**Installation and
Operation Manual**
V30-991-2400C

Peristaltic Pumps

Vector 3000 Series

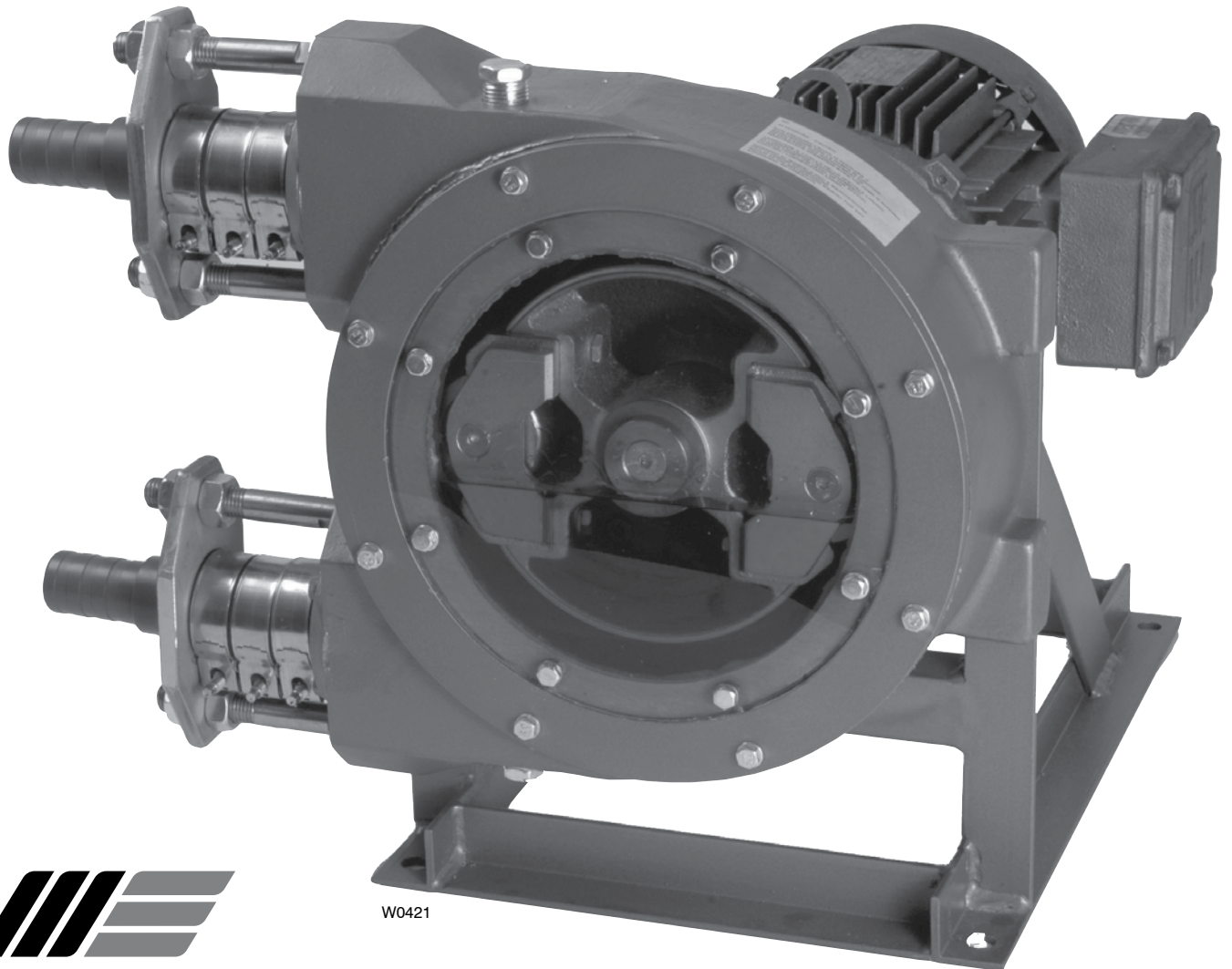

W0421



WANNER ENGINEERING, INC.

1204 Chestnut Avenue, Minneapolis, MN 55403

TEL: (612) 332-5681 FAX: (612) 332-6937

TOLL-FREE FAX [US only]: (800) 332-6812

www.vectorpump.com

email: sales@wannereng.com

Vector 3000 Contents

Contents

Important Precautions	2
Component Identification	2
How it Works	3
Inspection	3
Installation Planning	3
Site Plumbing	3
Pump Set-Up	4
Hose Compression Adjustment	4
Before System Start-Up	4
System Start-Up	5
Preventive Maintenance	5
Disassembly and Reassembly	5
Hose Removal	5
Hose Replacement	5
Troubleshooting	6
Storage	6
Spare Parts	6
Parts	7
Warranty	8



CAUTION

Important Precautions

- To avoid personal injury or pump damage, follow all instructions and safety precautions carefully.
- Don't exceed the manufacturer's recommended RPM or pressure limits.
- Follow all codes and hydraulic recommendations on installation and operation of the pumping system.
- To prevent vibration, mount the pump and motor securely to a rigid, level base.
- For safety and easier servicing, provide adequate work space around the pump. Allow space to remove the front cover, hose clamps, hose, and drive unit.

W0387

Component Identification

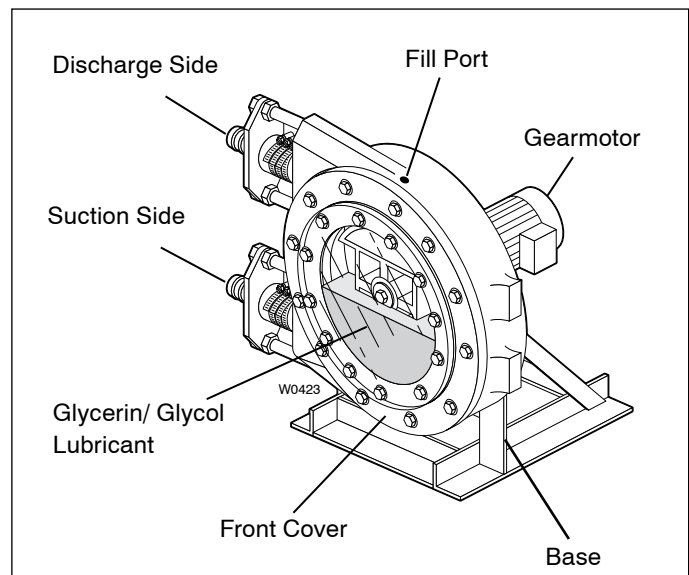

Vector 3000 Installation

How it Works

Two roller assemblies, mounted on a rotor, alternately compress a thick-walled hose in a patented concentric guide. As the rollers rotate, they push the liquid in the hose from the suction side of the pump to the discharge side. Also after a roller passes the hose opens which creates a vacuum on the suction side which results in even continuous pumping.

Inspection

The pump must be checked upon receipt for any possible damage or incomplete shipment. Notify Wanner Engineering of any discrepancies immediately.

Check all boxes or packages containing spare parts or accessories packed with the pump.

Installation Planning

Location

Locate the pump near to the liquid source, so that the suction line is short and direct.

Note: When practical, locate the pump above the level of the liquid; if the hose fails, the pumpage drains back into the tank.

Foundation

The foundation should be sufficiently rigid and substantial to absorb any vibration, and to permanently support the base plate at all points. A concrete foundation, poured on a solid footing of adequate thickness to support the pumping unit provides the most satisfactory foundation.

The base plate should be installed in a level position. The size and location of the base mounting holes are shown on the pump specification sheets. Use the dimensions provided in the pump specification data sheets for general piping.

Note: For a detailed description of proper procedures for grouting base plates, refer to the Hydraulic Institute Standards.

Site Plumbing

Inlet Piping

- Size the inlet line one or two sizes larger than the pump suction opening.
- Suction lines should be as short and direct as possible.
- Size the suction line so that the velocity will not exceed 1 – 3 ft/sec.

$$\text{Velocity} = \frac{0.408 \times \text{GPM}}{\text{Pipe I.D.}}$$

- Install 4-5 feet of reinforced flexible hose between pump and rigid piping to absorb vibration, expansion and contraction, and to make maintenance easier. (See Figure 1.)

Note: The flexible hose reinforcement must be capable of withstanding a vacuum in order to avoid collapsing that will restrict flow.

- Install an inlet pressure/vacuum gauge on the inlet side of the pump.
- To reduce turbulence and resistance, do not use 90° elbows. If turns are necessary in the suction line use 45° elbows or long sweeping elbows when required.
- Install piping supports where necessary to relieve strain on the inlet line and to minimize vibration.
- In extreme cases, a pulsation dampener may be required to decrease acceleration head.

Discharge Piping

- Size the discharge line to be at least the size of the pump inlet connection.
- Between the pump and hard piping, use 4-5 feet of flexible hose to reduce pulsations. (See Figure 1.)
- Install piping supports where necessary to relieve strain on discharge piping and to minimize vibration.
- Install a pressure gauge in the discharge piping.
- In extreme cases, a pulsation dampener may be required to absorb excessive pulsation (caused by high pump speed and long discharge lines).

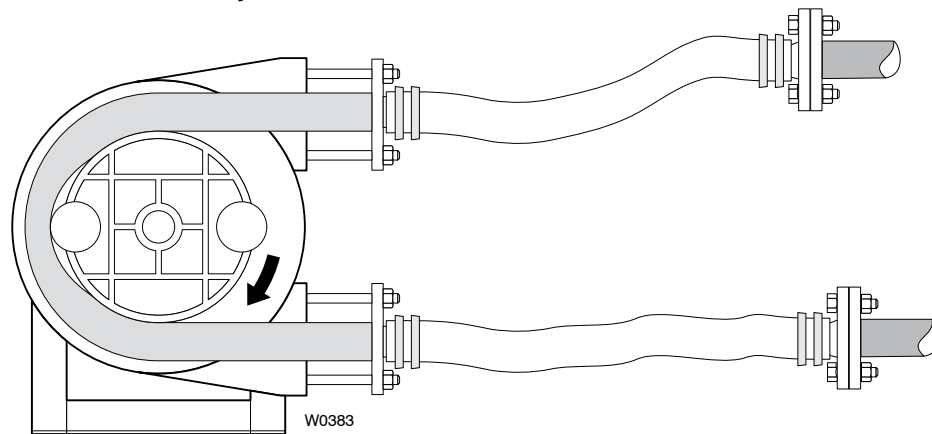

Figure 1.



Vector 3000 Installation - Start-Up

Pump Set-Up

Note: Refer to the Parts List Illustration. The numbers in parentheses () are the Reference Numbers used in the Parts List.

1. Make sure pump is completely assembled, and that all fasteners, hose clamps, etc. are properly tightened.
Note: The chamber should not be filled with lubricant at this time.
2. Remove transparent inspection window front cover (4) and gasket (3) so that rotor (9) is accessible. There should be light film of **non-petroleum** silicone on hose (18) in area of roller assembly (10) contact. If not, apply.
3. Connect motor per motor manufacturer's instructions.
4. Run pump and check proper rotor rotation. If rotor rotation is wrong, check motor terminals for proper connection.
5. Pump is now ready for hose compression adjustment.

Hose Compression Adjustment

Roller pressure is not set at the factory because it must be adjusted specifically to the application requirements. For optimum hose life, set just enough compression to accomplish desired pump operation, vacuum and discharge pressure. The more the hose is compressed the shorter the hose life.

Note: The pump does not need to be filled with lubricant to adjust hose compression. However, be sure that non-petroleum silicone has been applied on the hose in the area of roller contact. This will protect the hose during compression adjustment.

1. Remove window front cover (4) and gasket (3) as in Pump Set-Up above.
2. Start pump.
3. Place hand over suction port and check whether roller is compressing hose enough to create vacuum.
4. Gradually add shims and continue testing until vacuum exists. (Maximize hose life by installing only enough shims for pump application.)
5. Make sure each roller assembly (10) has same number of shims.
6. Install front cover and gasket.
7. Fill pump with quantity of lubricant shown in table below, to level just below pump shaft (Lubricant can be filtered to 100 microns and used again).

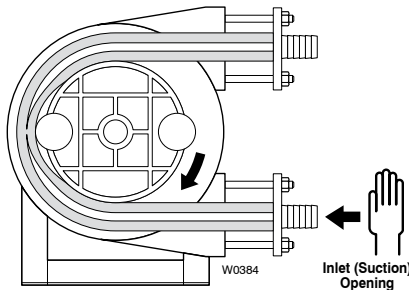

Model	Lubricant Capacity
3005	1.6 Quarts
3007	2.6 Gallons

Before System Start-Up

Before you pump fluid through the system, be sure that:

1. All connections are tightly secured.
2. See Hose Identification Table. Hose material is compatible with fluid being pumped, and hose design matches duty cycle and discharge pressures.

Hose Identification		
Extruded	Code	Description
Hypalon	HE	Black color, shiny smooth surface
Neoprene	PE	Flat black color, rough surface, rubber smell
Varprene	VE	Cream color, smooth surface
Silicone	SE	Rust color, smooth surface
Pharmed®	FE	Cream color, Pharmed® name on hose
Fiber Braided		
Hypalon	HF	Black color, yellow stripe, double braided
EPDM	EF	Black color, white stripe, double braided
Natural Rubber	NF	Black color, green stripe, double braided (standard duty)
Natural Rubber	MF	Black color, no stripes, thick double braids (heavy duty)
Nitrile Rubber	BF	Black color, white inner hose
Nitrile Rubber - Oil Rated	OF	Black color, HBRF-HY-K stamped on hose

3. See Material Operating Temperatures Table. Temperature of fluid pumped is within operating temperature range of hose material installed in pump. Hose material can be identified by 5th and 6th digit of pump model number. E.g. 3005-NF-BB-D2, where 'NF' designates natural rubber.

CAUTION: Contact factory when pumping a fluid that is within 15° F of the maximum hose temperature. Take safety precautions to insure hot pumpage does not harm operators

Material Operating Temperatures	
Material	Operating Temperatures
EPDM	0 to 180° F
Hypalon	0 to 180° F
Neoprene	50 to 130° F
Silicone	0 to 180° F
Varprene	0 to 160° F
Natural Rubber	0 to 185° F
Nitrile Rubber	0 to 160° F
Pharmed®	0 to 180° F



Vector 3000 Maintenance - Disassembly

System Start-Up

1. Connect system piping to the inlet and discharge connectors.
2. Open all shut-off valves to the system.
3. Start the pump.
4. Monitor pump for any signs of leakage.
5. Monitor pump performance. In the event flow and pressure are not satisfactory, repeat the hose compression adjustment procedures above. This will require the lubricant in the pump case to be drained by removing the drain plug (12). The pumpage fluid will have to be drained as well. Refer to the Disassembly and Reassembly Section for cautions on handling.

Preventive Maintenance

A preventive maintenance program can increase the pump life. THE PROCEDURES DESCRIBED IN THIS MANUAL DO NOT REPLACE THE EXPERIENCE AND THE KNOWLEDGE OF OUR TECHNICAL STAFF. Please feel free to contact Wanner Engineering if you need assistance.

Routine Inspection

1. Verify pump is pumping.
2. Check lubricant level (should be just below shaft).
3. Make sure noise and vibration are within normal range

Monthly Inspection

1. Check that all fasteners are properly tightened.
2. In addition to routine inspection, check that base plate mounting bolts are tight and not corroded.
3. Check flow rate and pressure. If operating conditions have not changed and the pumps performance does not meet requirements, inspect parts for wear.

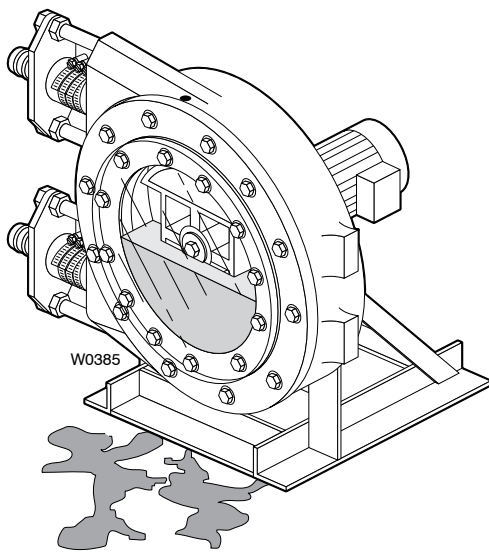

4. Verify there are no abnormal leakages of lubricant or pumpage.

Disassembly and Reassembly

Before disassembling the pump for repair, contact Wanner Engineering to make sure that required original spare parts are available.

CAUTION: The pump may have handled dangerous or toxic liquids: it is therefore necessary to protect against contact with skin, eyes, etc.

Liquid must be recovered and eliminated according to all applicable environmental laws.

If a pump has been used to pump corrosive or toxic liquids, it must be thoroughly drained and cleaned before returning it to the manufacturer for reconditioning.

Hose Removal

1. Turn off and lock-out power to motor.
2. Disconnect pump from piping system.
3. Drain lubricant from pump case by removing drain plug (12), (Lubricant can be filtered to 100 microns and used again).
4. Loosen hose clamps and tie rod nuts (26) from inlet and discharge.
5. Remove hose connectors (25) and internal sleeve (23) from inlet and discharge.
6. Remove flange (20) and flange gasket (19) from inlet and discharge.
7. Remove front cover (4).
8. Position rotor (9) so one roller assembly (10) is not compressing hose (18). Then remove roller assembly and shims.
9. Turn rotor (9) 180° to position second roller assembly in idle position.
10. Remove hose (18).
11. Clean inside of case of debris and make sure rollers are in good working condition.

Hose Replacement

1. Turn off and lock-out power to motor.
2. Spread non-petroleum silicone on idle roller assembly (10) in pump.
3. Check for correct length of hose (18). (Model 3005 hose length: 850 mm or 33.46 inches)
4. Install hose and make sure length of hose extending from inlet and discharge are same.
NOTE: It is important to have a 1 to 2 mm gap between the hose and the inside of the pump casing.
5. Install hose flanges (20) and flange gaskets (19).
6. Install internal sleeves (22) and external sleeves (23).
7. Install hose clamps (27), do not tighten.
8. Install connectors (25) and tighten hose clamps.
9. Rotate rotor (9) 180° and install second roller assembly and same number of shims as removed (if any).



Vector 3000 Troubleshooting

Hose Replacement (Cont'd)

10. Spread non-petroleum silicone on idle roller assembly.
11. Complete assembly.
12. Check hose compression. Compression may vary with new hose due to variations in hose diameter. See paragraphs on Hose Compression Adjustment and System Start-Up in Installation Section.

Troubleshooting

1. Pump Temperature

Pump temperature can increase because of:

- Unsuitable lubricant
- Excessive temperature of the product
- Worn out bearings
- Roller overshimming
- Excessive pump speed

2. Low Flow or Low Pressure

The capacity or the pump discharge pressure can be lower than nominal because of:

- Closed valves on suction or discharge
- Wrong roller pressure adjustment
- Hose rupture (in which the pump casing gets filled with the pumpage)
- Partially blocked suction line or not enough product in the suction tank
- Pump has not been properly selected in terms of speed, excessive suction and discharge piping, excessive product viscosity, etc.
- Air in the suction line

3. Vibration and Water Hammering of Pump and Piping

The Vector pump has a pulsating flow that may cause vibrations on the pump and on the piping whenever one of the following circumstances occurs:

- Suction and discharge piping is not anchored
- Excessive pump rotating speed in conjunction with a long suction piping and with a high specific gravity
- Suction and discharge piping is too small

4. Short Hose Life

Hose life is generally determined by the following parameters:

- Chemical attack; unsuitable material for the pumped liquid
- High pump speed; a low speed increases hose life
- Discharge pressure and product temperature; an excessive pressure and/or a high product temperature create higher stress to the pump and on the hose reinforcement, thus reducing its life
- Excessive shimming of the pressure rollers (10)

5. Friction Pulling of the Hose within the Pump Casing

The hose can be pulled inside the pump casing because of:

- Insufficient or lacking lubricant
- Excessive inlet pressure
- Non-compressible particles or objects within the hose that do not allow the liquid to flow. Thus, the hose cannot be compressed and, consequently, can be pushed within the pump casing
- No gap between hose and casing

Storage

Store the pump in a dry and clean environment, with no vibrations.

Install protective plugs into/over the pump connections in order to avoid dirt or foreign material from entering the pump casing.

In case the pump is going to be stored for a long period, idle one of the pressure rollers to avoid leaving any marks and potential damage to the hose, possibly causing problems when starting the pump. (Do not store with hose in compression.)

Spare Parts

For correct spare parts, please contact Wanner Engineering with:

- Pump model
- Serial number

This information is indicated on the pump name plate placed on the pump.

Recommended Spare Parts

Item	Description	Quantity/Pump
3	Gasket, front window	1
6	Gasket, front cover	1
10	Roller Holder Assembly	2
18	Hose	1
19	Gasket, flange	2
-	Lubricant, Model 3005	1.6 qts
	Model 3007	2.6 gals



Vector 3000 Parts

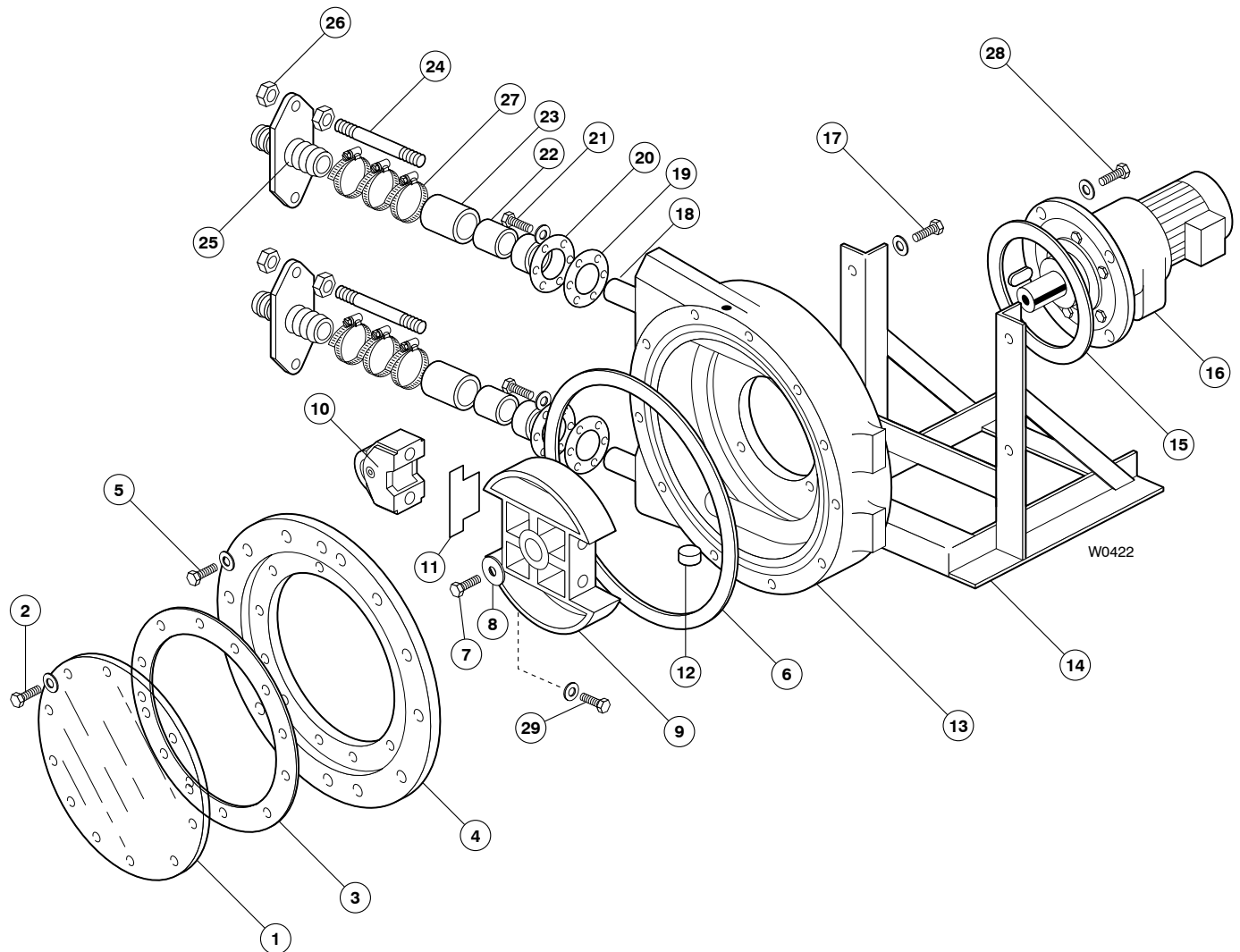

Ref No.	Description	Qty/Pump
1	Window, Front	1
2	Cap Screw, Front Window	8
3	Gasket, Front Window	1
4	Cover, Front	1
5	Cap Screw, Front Cover	8
6	Gasket, Front Cover	1
7	Bolt, Rotor	1
8	Washer, Rotor	1
9	Rotor	1
10	Roller Holder Assembly	2
11	Shim	6
12	Plug, case drain	1
13	Casing	1
14	Base	1
15	Gear motor gasket	1

Ref No.	Description	Qty/Pump
16	Gear motor	1
17	Cap Screw, Mounting	4
18	Hose	1
19	Gasket, Flange	2
20	Flange	2
21	Cap Screw, Flange	8
22	Sleeve, Internal	2
23	Sleeve, External	2
24	Tie Rod	4
25	Connector	2
26	Nut, Tie Rod	8
27	Clamp, Hose Connection	6
28	Bolt, Gear motor	4
29	Cap Screw, Roller Holder	4



Vector 3000 Warranty

Limited Warranty

Wanner Engineering, Inc. extends to the original purchaser of equipment manufactured by it and bearing its name, a limited one-year warranty from the date of purchase against defects in material or workmanship, provided that the equipment is installed and operated in accordance with the recommendations and instructions of Wanner Engineering, Inc. Wanner Engineering, Inc. will repair or replace, at its option, defective parts without charge if such parts are returned with transportation charges prepaid to Wanner Engineering, Inc., 1204 Chestnut Avenue, Minneapolis, Minnesota 55403.

This warranty does not cover:

1. The electric motors (if any), which are covered by the separate warranties of the manufacturers of these components.
2. Normal wear and/or damage caused by or related to abrasion, corrosion, abuse, negligence, accident, faulty installation or tampering in a manner which impairs normal operation.
3. Transportation costs.

This limited warranty is exclusive, and is in lieu of any other warranties (express or implied) including warranty of merchantability or warranty of fitness for a particular purpose and of any non contractual liabilities including product liabilities based on negligence or strict liability. Every form of liability for direct, special, incidental or consequential damages or loss is expressly excluded and denied.



WANNER ENGINEERING, INC.

1204 Chestnut Avenue, Minneapolis, MN 55403

TEL: (612) 332-5681 FAX: (612) 332-6937

TOLL-FREE FAX [US only]: (800) 332-6812

www.vectorpump.com

email: sales@wannereng.com