

Universal Industrial 5000 Series

ROTARY POSITIVE DISPLACEMENT ECP PUMPS



For more than half a century, Waukesha Cherry-Burrell has been a leader in the design, manufacturing and application of external circumferential piston (ECP) style, rotary positive displacement pumps. Waukesha Cherry-Burrell PD pumps are in service around the world in demanding sanitary, pharmaceutical processing, and difficult chemical, industrial, and pulp and paper applications.

Users of Waukesha Cherry-Burrell PD pumps benefit from decades of continuing product improvement. Steady advances in design, metallurgy and fabrication techniques have yielded progressively higher levels of performance and service life.

SPX FLOW, Inc. (NYSE:FLOW) is a leading manufacturer of innovative flow technologies, many of which help define the industry standard in the market segments they serve. From its headquarters in Charlotte, North Carolina, it operates a sales and support network, centers of manufacturing excellence, and advanced engineering facilities, throughout the world. Its cutting-edge flow components and process equipment portfolio includes a wide range of pumps, valves, heat exchangers, mixers, homogenizers, separators, filters, UHT, and drying technology that meet many application needs. Its expert engineering capability also makes it a premium supplier of customized solutions and complete, turn-key packages to meet the most exacting of installation demands.

Incorporating many leading brands, SPX FLOW has a long history of serving the food and beverage, power and energy, and industrial market sectors. Its designs and engineered solutions help customers drive efficiency and productivity, increase quality and reliability, and meet the latest regulatory demands. In-depth understanding of applications and processes, state-of-the-art Innovation Centers, and advanced pilot/testing technology further assist in optimizing processes and reducing timescales to reliably meet production targets.

To learn more about SPX FLOW capabilities, its latest technology innovations and complete service offerings, please visit www.spxflow.com.

Long-life engineering features. High volumetric efficiency, low shear and reduced operational and maintenance costs.

PRODUCT FEATURES AND BENEFITS

- 316L stainless steel body & cover and 316 stainless steel shafts.
- Non-galling Waukesha "88" alloy rotors standard, permits running at tighter clearances and pumping a wide range of viscosities.
- Very low shear, product not damaged during pumping.
- Wide selection of commercial seals, packing, and triple lip seals including cartridge seals.
- Requires less horsepower than Progressing Cavity Pumps.
- Bidirectional flow.
- Upper or lower shaft positions.
- Pumps filled with most settled slurries will start without damaging pump or seals.
- Expanded fluid cavities can pump liquids with large solids without jamming or knocking rotors out of timing.
- Unique timing gear arrangement reduces troublesome maintenance issues, as experienced on conventional lobe pumps.
- No cross contamination of lubricating oil or grease into product zone, due to unique gear case design.
- Pumps are energy efficient, and when needed easily maintained, and repaired.
- Versatile 3-way mounting of gear case, including vertical alignment of ports.



Typical industrial product applications

Long-life Features

- 200 psi (13.8 bar) pressure capability.
- Heavy duty Cast Iron bearing frame.
- No internal rotor contact.
- Double tapered roller bearings on all models.
- Grease lubricated bearings for positive lubrication to all bearings over entire speed, temperature and pressure range.
- Body retaining screws for maintaining mechanical seal loading and body position during inspection.
- Steel-It Paint.
- Remanufacturing Program to extend life and reduce costs.
- Carbon cover bushings to minimize shaft deflection and wear

Available Options

- High strength 17-4 PH shafts for severe duty applications.
- 300 lb & DIN flanges, and NPT port connections.
- Stainless steel bearing retainers.
- Bearing isolators protect bearings from contamination.
- Jacketed or internal by-pass relief valve covers.
- Waukesha (ISR) Integral Speed Reducers, eliminates coupling alignment and saves space.
- 316L SS rotors. Review with factory for when to apply.
- External over-pressure relief valves for full flow relief
- Tru-Fit® integral gear drive motor drives for 5080.
- Armolloy® coating for abrasive service.
- Optional port sizes on 5040 thru 5060 models.
- Side mount pedestals for vertical porting.
- Hot and front face rotor clearances, for high temperature fluids.
- Alloy 88 & Rulon cover bushings.
- Ceramic coated packing sleeves.

Solvents

Acetone
Carbon "Tet"
Spirits
M.E.K.
Turpentine



Oils & Lubricants

Crude Oil
Diesel #2 Oil
Bunker Oil
Lubricant Oil
Fuel Oils
Greases
Oil Additives



Other

Acids	Printing Ink
Adhesives	Resins
Alkalies	Silicone Emulsions
Animal Fats	Soaps
Ammonium Nitrate	Sludges
Defoamers	Starches
Glue	Urea
Latex	
Lacquer	
Melamine	
Paper Coatings	
Polymers	
Polyvinyl Alcohol	



STANDARD CHANNEL STEEL BASE

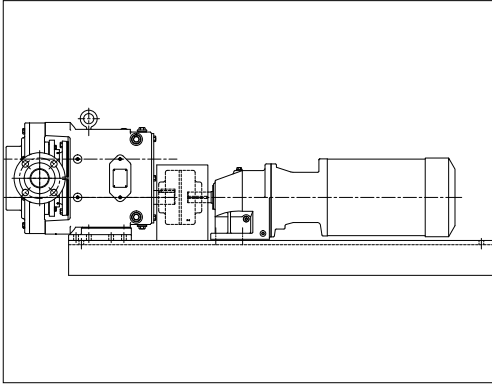

VERTICAL PORTED UNIT

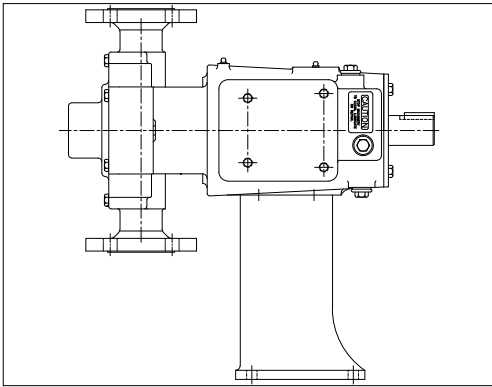

Installation Flexibility

- Bi-directional flow. Rotors, locked in place, rotate securely in either direction. No flow direction/shaft position specifications.
- Versatile 3-Way mounting of gearcase, including vertical alignment of ports.
- Upper or lower shaft position. Upper shaft position is standard.
- Side mount pedestals with left hand shaft position as standard. Right hand shaft position is optional.

Drive Options

- Standard is direct connected gear motor with coupling & SS guard mounted on base.
- WCB ISR Integral Speed Reducer Sizes 49, 79 and 239.
- Mechanical and Electronic Variable Speed Drives.
- Hydraulic Motor Drives.
- Close coupled Tru-Fit® gear motors mounted on Model 5080.

Bases

- Channel Steel with steel-it paint is standard.
- T B Woods Coupling with SS coupling Guard is standard.
- Fabricated Steel epoxy painted
- 304 SS unpolished flat plate
- Portable Base with rubber wheels

Tru-Fit® Version of 5080 model Pump

- Vertical ported unit shown
- Standard horizontal ports also available

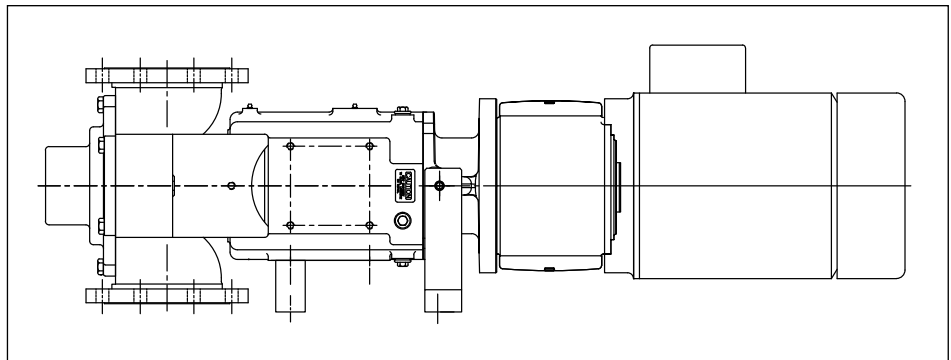

Time-tested Waukesha Cherry-Burrell rotary pump; external circumferential piston (ECP) operating principle.

THEORY OF OPERATION

In the Waukesha Cherry-Burrell design, arc-shaped “pistons” (rotor wings) travel in annular-shaped cylinders machined in the pump body; the resulting long sealing path reduces slippage and produces a smooth flow of product without destructive pulses or pressure peaks and without valves or complex parts.

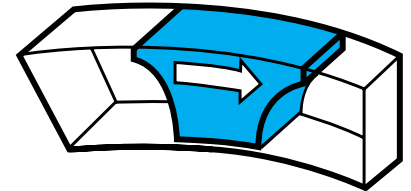

FOR LOW VISCOSITY FLUIDS

Rotors, made of Waukesha “88” alloy, can be run with close clearance to the 316L stainless steel fluid head, without galling or seizing should inadvertent pressure surges cause contact. The close clearances combined with the rotor geometry, which gives a long sealing path between the pump inlet and outlet, means low slip operation. As a result, you achieve: high volumetric efficiency, metering capability and good flow control.

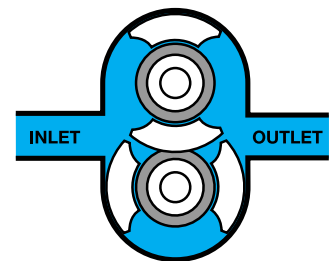

FOR HIGH VISCOSITY FLUIDS

The large fluid cavities of the rotors, plus the large, easy entry anti-cavitation ports, allow efficient pumping of high viscosity fluids, slurries or even liquids with large chunks or particles.

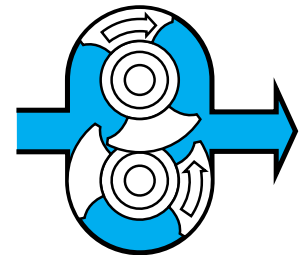

FOR NON-LUBRICATING AND ABRASIVE FLUIDS

The unique Waukesha Cherry-Burrell design has no sliding or rolling contact and no rotor-to-rotor contact. This produces MAXIMUM SERVICE LIFE even under severe operating conditions.

All the Traditional Waukesha-Cherry Burrell Values.

The Waukesha Cherry-Burrell Universal Industrial 5000 Series gives you . . .

High pressure capability: 200 psi/13.8 bar*.

Long service life: High capacity components for long trouble-free service.

Metal rotor: Waukesha "88" non-galling alloy, for close running clearance.

*For higher pressures and temperatures consult the factory.

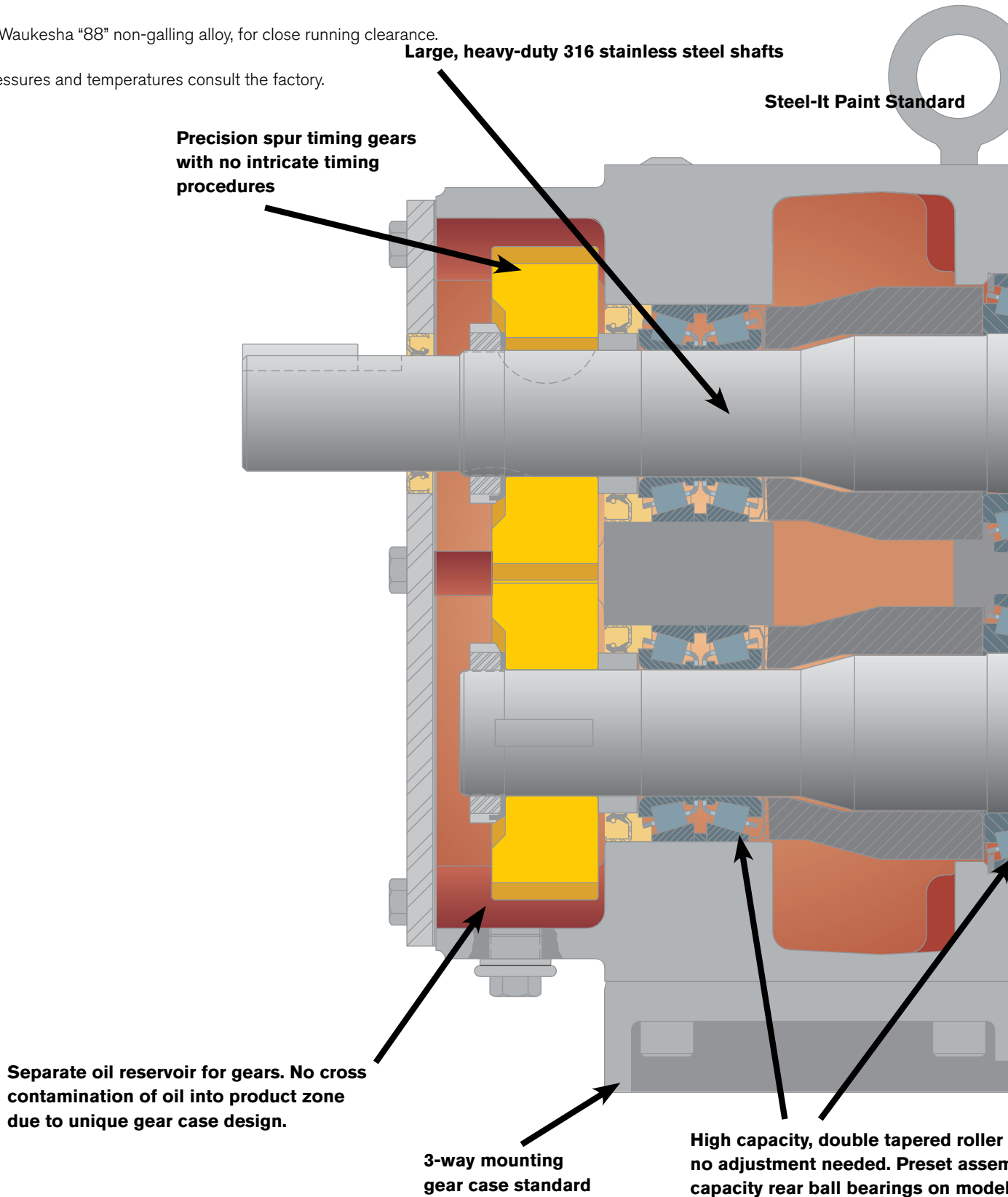

Commercial single and double mechanical seals, packing, and triple lip seals in both standard and cartridge configurations options for every service.

316L stainless steel; design conforms to CE and ASME standards

Carbon Cover bushing

Optional bearing isolators

Front bearing fixed; rear bearing floating. Better control of thermal expansion when handling hot products.

See Through Sight Glass for Quick Oil Level Check

Drain Plugs for Easy Service

bearings; assemblies. High 5040.

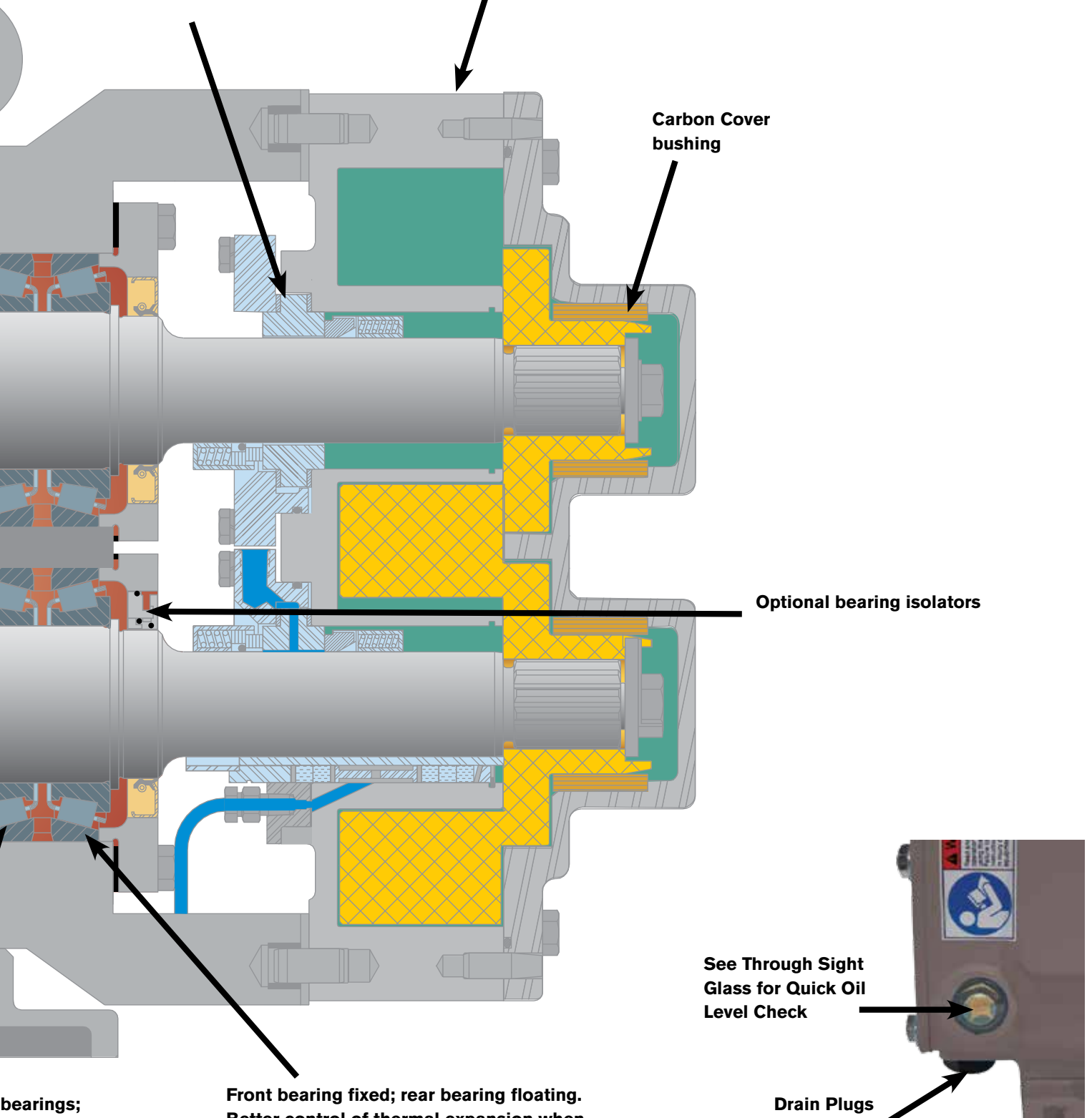

Seal Options

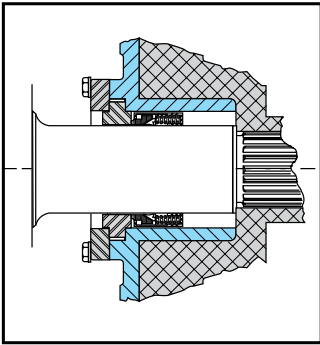

Single Inner Mechanical Seal
 J. Crane Type 9 with carbon and ceramic seal faces standard. Narrow face seal with TC and SC seal faces as option. Consult factory.

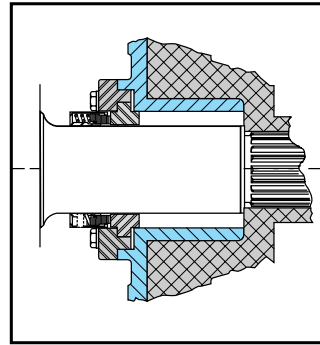

Single Outer Mechanical Seal
 J. Crane Type 8B2 with carbon and ceramic seal faces standard.

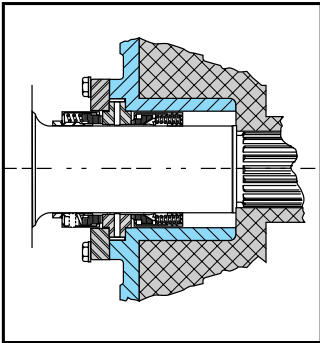

Double Mechanical Seal
 Used with flushing fluid to cool, lubricate, flush away residue. Best arrangement for severe service. Combines above single inner and outer seals.

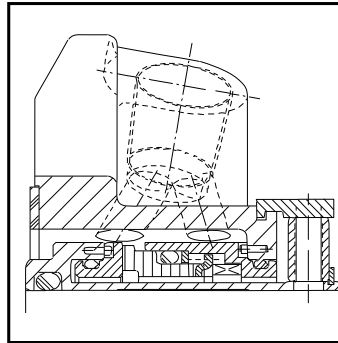

Cartridge Seals
 Consult factory for availability. See instruction manual 95-03012 for stuffing box dimensions.

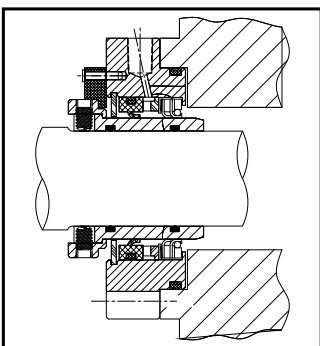

Triple Lip Seal
 Available in Cartridge design. Consult factory.

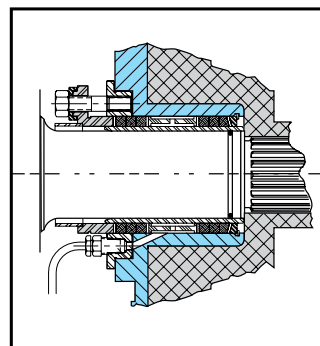

Packing
 J. Crane Style 1335 TFE impregnated braided acrylic with stainless steel sleeve standard.

Elastomer choices for "O" rings:
 Buna-N, Fluoroelastomer (FKM), EPDM, Silicone, Perfluoroelastomer (FFKM), PTFE Encapsulated
Mechanical seal material options: Carbon, Ceramic, Silicon Carbide, Tungsten Carbide

Dimensional Data

***NOTE:** CP3 is the maximum dimension for all vented and jacketed cover options. Dimensions are for guidance purposes only. Contact your SPX FLOW Representative if more detailed measurements are needed.

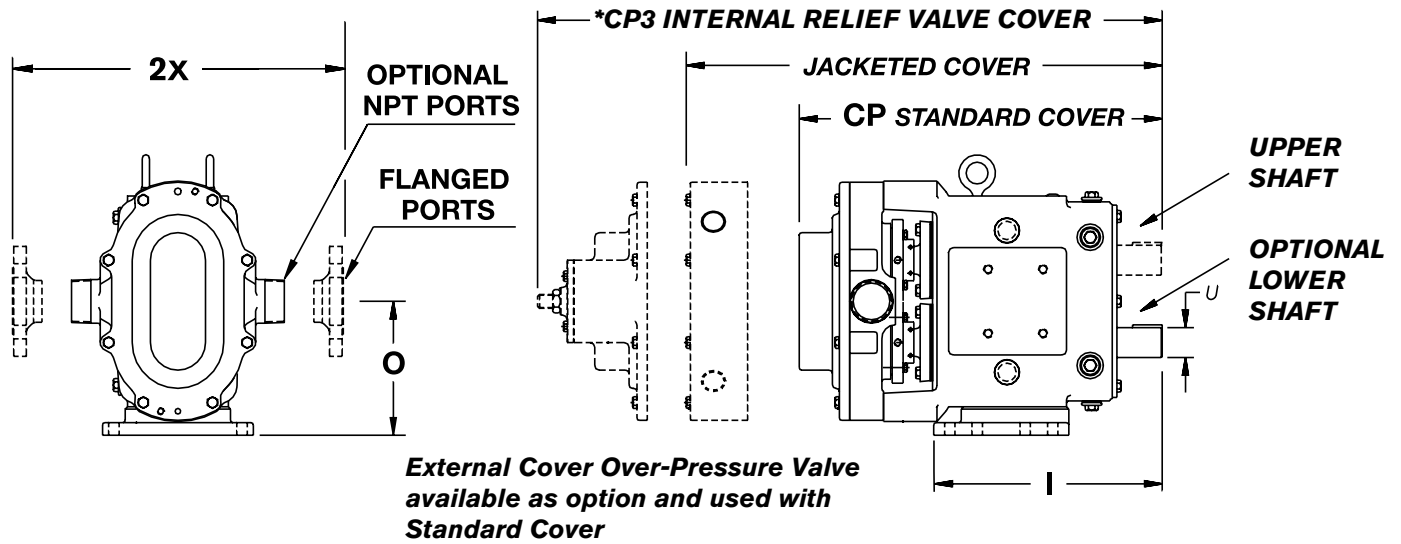

Product Specifications

PUMP MODEL		CP	CP3*	I	O	PORT SIZE	U	2Y	WT LBS KG
5040	in	16.66	18.84	8.84	5.21	1- 1/2" - 150# flange	1.250	11.85	100
	mm	423	479	224	132	---	32	301	45
5050	in	20.00	23.43	12.54	7.31	2" - 150# flange	1.625	13.24	240
	mm	508	595	318	186	---	41	336	109
5060	in	20.89	24.32	12.48	7.31	2 - 1/2" - 150# flange	1.625	13.46	245
	mm	530	618	317	186	---	41	342	111
5070	in	25.94	28.43	14.93	9.38	4" - 150# flange	2.000	14.75	475
	mm	659	722	379	238	---	51	375	215
5080	in	30.26	34.30	17.70	10.37	6" - 150# flange	2.375	16.00	810
	mm	768	871	450	263	---	60	406	367

PUMP MODEL	DISPLACEMENT PER REVOLUTION	NOMINAL CAPACITY* TO	INLET AND OUTLET	OPTIONAL INLET AND OUTLET	PRESSURE RANGE*	MAXIMUM RPM	TEMP RANGE**
5040	0.060 GAL. (0.227 LITER)	36 GPM (8.2 m ³ /hr.)	1 1/2"	2"	200 PSI (13.8 bar)	600	Std. Rotors: -40°F (-40°C) to 200°F (93°F)
5050	0.153 GAL. (0.579 LITER)	90 GPM (20.4 m ³ /hr.)	2"	2 1/2"	200 PSI (13.8 bar)	600	
5060	0.254 GAL. (0.961 LITER)	150 GPM (34.1 m ³ /hr.)	2 1/2"	3"	200 PSI (13.8 bar)	600	
5070	0.440 GAL. (1.666 LITER)	260 GPM (59.1 m ³ /hr.)	4"	---	200 PSI (13.8 bar)	600	Hot Clearance Rotors: 180°F (82°C) to 300°F (149°C)
5080	0.754 GAL. (2.854 LITER)	450 GPM (102.2 m ³ /hr.)	6"	---	200 PSI (13.8 bar)	600	

NOTE: Consult factory for available rectangular flange inlets. Dimensions are for guidance purposes only. Contact your SPX FLOW Representative if more detailed measurements are needed.
 * For capacities above 450 GPM (102.2 m³/hr) see bulletin FH-1725 for 6" and 8" 420/520 UHC (ECP rotors). For Lobe rotors up to 525 GPM (119.2 m³/hr see bulletin FH-1733 for UL (Lobe rotors) Series of pumps. **Contact application engineering for higher pressure or higher temperature applications.

Behind every Waukesha Universal Pump

ENGINEERING

Research, design and application engineers at SPX FLOW possess extensive backgrounds in their respective fields. You can draw on this experience to solve pumping problems or to counsel on process systems design. The imagination and resourcefulness of our engineers have often helped improve our customers' profits through production efficiencies.



TESTING

Ideas do not remain abstract long at SPX FLOW. Application of our products to our customer's specific needs often requires practical testing using real-world parameters. We have a fully equipped and staffed facility for this purpose. For example, the Rheology Laboratory tests applications involving highly viscous fluids.



SALES & SERVICE NETWORK

SPX FLOW's trained sales and application engineers are always available for personal consultation to help solve any installation or operational problem. A large number of fully trained SPX FLOW stocking distributors throughout the country and around the world provide quality Waukesha Universal replacement parts and service.

QUALITY CONTROL

To maintain the product line's reputation for quality and to assure that every unit is shipped "ready to install," each Waukesha pump is thoroughly inspected at every stage of manufacturing and assembly and then tested for design specification.



METALLURGICAL CONTROL

SPX FLOW's reputation for pump reliability under severe operating conditions is directly related to carefully controlled casting production and consistency of metallurgical properties. It is this control that assures castings of uniform analysis that will perform dependably under all operating conditions.

When it is time to repair ...

SPX FLOW offers the following options – you pick the one that meets your needs.

Factory Remanufacturing Program

- No need to return your pump until you receive your new remanufactured pump.
- Substantial savings over new pump.
- All remanufactured pumps must pass a 25 point inspection process and undergo performance testing.
- Only OEM genuine parts are used in the remanufacturing process and you receive a guaranteed warranty and quality certificate with each pump.
- New pumps eligible for Remanufacturing Program twice.

Factory Inspect and Advise Program

- Return your pump for complete factory inspection.
- Cost effective options to match your performance/budget needs.
- Your pump body may be remachined up to 6 times.
- Replacement rotors and parts available.
- Factory warranty.

SPX FLOW Certified Pump Repair Centers

- Local distributors with factory trained and certified service technicians.
- Quick local response.
- Genuine WCB parts.
- Flexible repair programs to meet your needs.
- Local warranty.

SPX FLOW Warranty

Seller warrants its products to be free from defects in materials and workmanship for a period of one (1) year from the date of shipment. This warranty shall not apply to products which require repair or replacement due to normal wear and tear or to products which are subjected to accident, misuse or improper maintenance. This warranty extends only to the original buyer. Products manufactured by others but furnished by seller are exempted from this warranty and are limited to the original manufacturer's warranty.

Universal Industrial 5000 Series

ROTARY POSITIVE
DISPLACEMENT PUMPS

SPX FLOW

Adding a Powerful New Tool to Your Maintenance Program

SPX FLOW has recently launched its SPX Connect App allowing users the ability to access product support information 24/7 using a smart device with internet access.

A quick scan of the product's QR code will provide you with immediate access to:

- Product Descriptions and General Operating Specifications
- Maintenance Manuals and Documentation
- Maintenance Videos and Product Animations
- Distributor Look Up Feature
- Submit Quote Requests

SPX FLOW is committed to providing you with innovative products and technologies to help keep your process flowing.

Plan your next scan and download the Free SPX Connect App today.



SPX FLOW, Inc.

611 Sugar Creek Road
Delavan, WI 53115

P: (262) 728-1900 or (800) 252-5200

F: (262) 728-4904 or (800) 252-5012

E: wcb@spxflow.com

SPX FLOW reserves the right to incorporate our latest design and material changes without notice or obligation.

Design features, materials of construction and dimensional data, as described in this bulletin, are provided for your information only and should not be relied upon unless confirmed in writing. Please contact your local sales representative for product availability in your region. For more information visit www.spxflow.com.

The green ">" is a trademark of SPX FLOW, Inc.

ISSUED 10/2015 FH-1710

COPYRIGHT © 2015 SPX FLOW, Inc.