



## Alfa Laval SaniJet 20

Rotary jet head for high-impact tank cleaning for hygienic application

### Introduction

The Alfa Laval SaniJet 20 is a rotary jet head tank cleaning machine for hygienic environments. Built to clean tanks with capacities from 5-30 m<sup>3</sup> it combines pressure and flow to create high-impact cleaning jets that rotate in a repeatable and reliable 360-degree cleaning pattern.

The SaniJet 20 minimizes the consumption of water, and cleaning media. Easy to customize to meet customer requirements, it allows companies to spend less time cleaning and more time producing.

### Applications

The Alfa Laval SaniJet 20 is designed for the removal of the toughest residues from hygienic tanks across a broad range of industries, such as in yeast propagation plants and in the food and beverage industries.

### Benefits

- 60% faster cleaning = more time for production
- Saves up to 70% of your cleaning cost
- High-impact cleaning in a 360° repeatable cleaning pattern
- Cleaning process can be validated using Alfa Laval Rotacheck

### Standard design

The choice of nozzle diameters can optimize jet impact length and flow rate at the desired pressure.

Alfa Laval offers a wide range of tank cleaning machines suitable for different duties and industries.

An alternative that offers performance similar to the Alfa Laval SaniJet 20 is the Alfa Laval SaniJet 20 UltraPure for hygienic applications that require full traceability of product-contacted parts and smooth qualification and validation processes through the Alfa Laval Q-doc documentation package.

### Working principle

The high-impact jet stream from the Alfa Laval SaniJet 20 rotary jet head covers the entire surface of the tank interior in a successively denser pattern. This achieves a powerful mechanical impact with a low volume of water and cleaning media.

The flow of the cleaning fluid makes the nozzles perform a geared rotation around the vertical and horizontal axes. In the first cycle, the nozzles lay out a course pattern on the tank surface. The subsequent cycles gradually make the pattern denser until at full cleaning pattern is reached. Once the full cleaning pattern is reached, the machine will start over again and continue to perform the next full cleaning pattern.

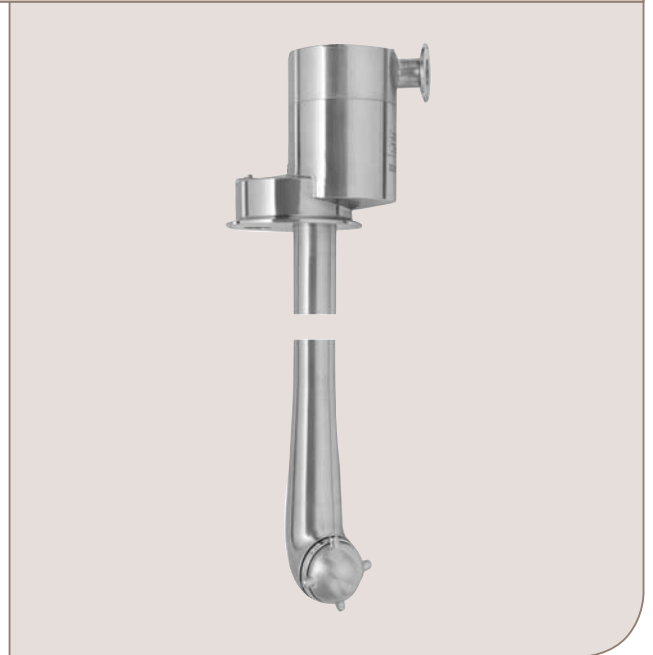

### Cleaning Pattern

Example - 2xø3.8LS

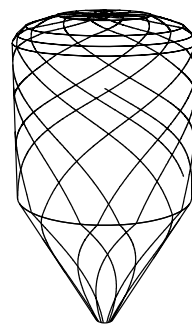

0.8 min.

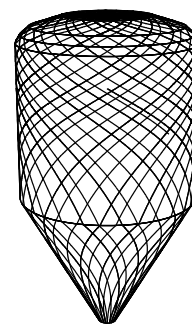

2.3 min.

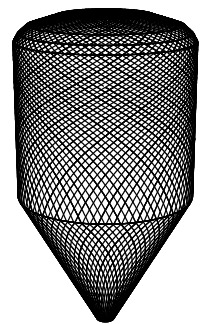

6.0 min.

### Certificates

2.2 material certificate, Q-doc and ATEX.



## TECHNICAL DATA

<b>Lubricant</b>	
Machine:	Self-lubricating with the cleaning fluid
Air motor:	Can operate non-lubricated
<b>Surface finish</b>	
Product contact parts:	Ra 0.8µm
<b>Impact throw length</b>	
Impact throw length:	1.5 - 4 m.
<b>Min. tank opening</b>	
Min. tank opening:	4" Clamp w. rotacheck 3" clamp - rotacheck N/A
<b>Pressure</b>	
CIP media working pressure:	3-13 bar
CIP media recommended pressure:	5-8 bar
<b>Air driven. Air quality:</b>	
Clean, filtered max.:	40µm
Dry, dew point max.:	5°C Non-lubricated possible
Air supply pressure:	max. 7 bar
Free air consumption:	Max. 2 l/sec. (8 m³/h)
Adjustable speed:	5 - 16 RPM
Cleaning time:	3 - 10 min

## PHYSICAL DATA

<b>Materials</b>	
316L (UNS S31603), PEEK*, Titanium Ti-GL	
Sealing:	EPDM* (standard), FPM* FFKM*
* FDA compliance 21CFR§177	
<b>Temperature</b>	
Max. working temperature:	90°C
Max. ambient temperature:	140°C
<b>Weight</b>	
Media-driven machine:	11 - 18 kg.
Air-driven machine:	11.7 - 19.2 kg.
<b>Connections</b>	
Inlet connection:	Clamp: 1" ISO 2852
Tank connection:	Clamp: 4" ISO 2852
Tank connection:	Clamp: 3" ISO 2852

**Note:** 3" Tank connection has no possibility of integrated rotacheck.

<b>Caution</b>	
Avoid hydraulic shock, hard and abrasive particles in the cleaning liquid, as this can cause increased wear and/or damage of internal mechanisms. In general, a filter in the supply line is recommended. Do not use for gas evacuation or air dispersion. For steaming we refer to the manual.	

### Options

- Electronic rotation sensor to verify 3D coverage
- Improved surface finish
- 3.1 certification for metallic parts by request
- With FFKM or FPM seal ring
- ATEX

### Qualification Documentation (Q-doc)

<b>Documentation specification</b>	
Q-doc	Equipment Documentation includes: <ul style="list-style-type: none"><li>- EN 10204 type 3.1 Material Inspection certificate</li><li>- FDA Declaration of Conformity</li><li>- ADI Declaration (TSE)</li><li>- QC Declaration of Conformity</li></ul>
ATEX	ATEX approved machine for use in explosive atmospheres. Media driven version: Category 1 for installation in zone 0/20 in accordance to Ex II 1 GD c T 140°C. Air driven version: Category 1 for installation in zone 0/20 in accordance to Ex II 1 GD c T140°C. Air driven unit: Category 2 for installation in zone 1/21 in accordance to Ex II 2 GD c IIC T4 Tamb -20°C to +40°C

### Flow Rate

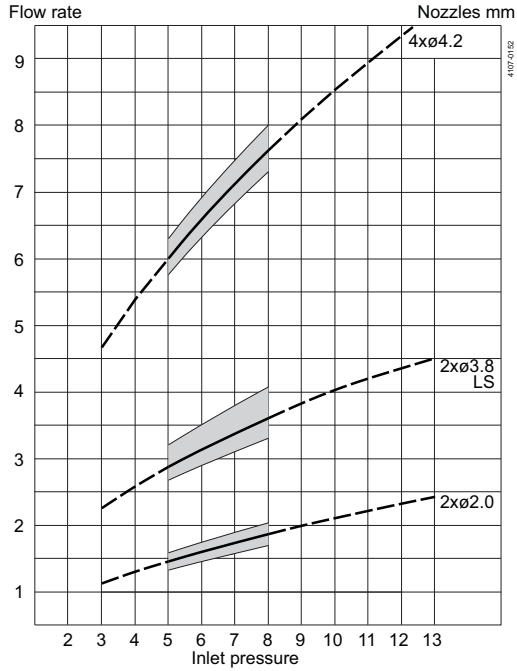

Recommended operating pressure: 5-8 bar

### Cleaning Time, Complete Pattern, Media driven

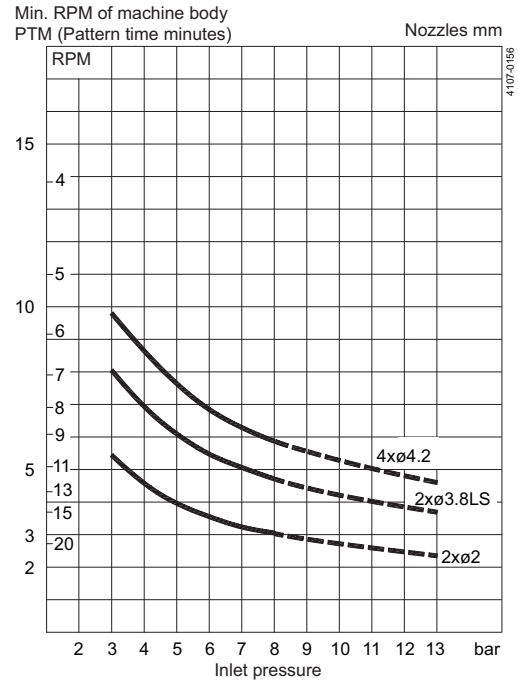

### Impact Throw Length, Media Driven

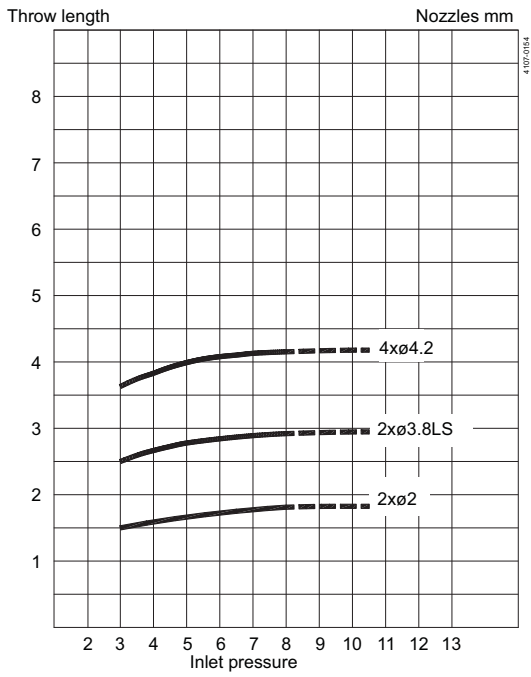

### Impact Throw Length, Air Driven

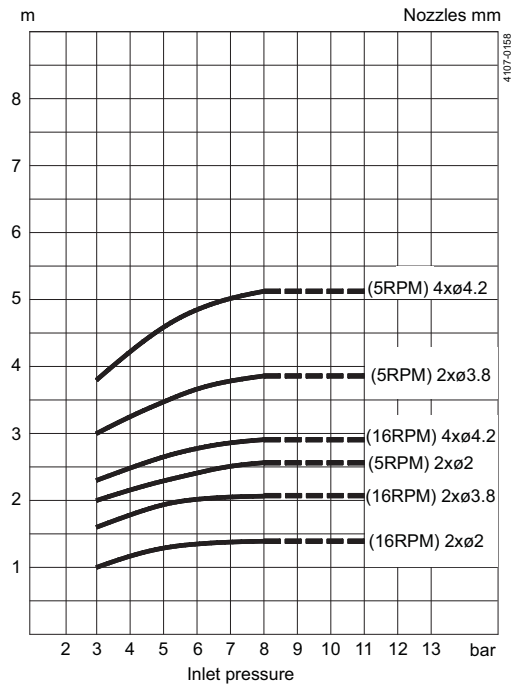

Dimensions (mm)  
Media Driven

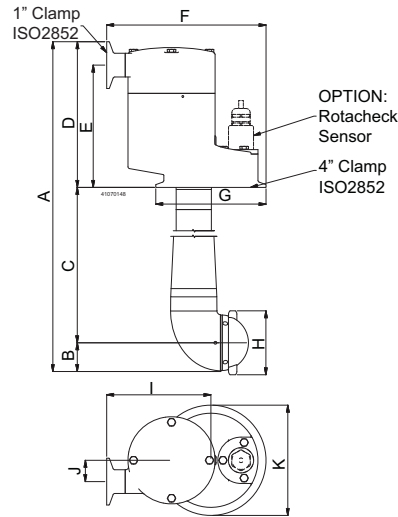

	A	B	C	D	E	F	G	H	I	J	K
mm	537 - 687 - 887 - 1187 - 1387 - 1687	31	350 - 500 - 700 - 1000 - 1200 - 1500	157.25	132	172	Ø119	Ø69	112.5	23	Ø119

Air Driven

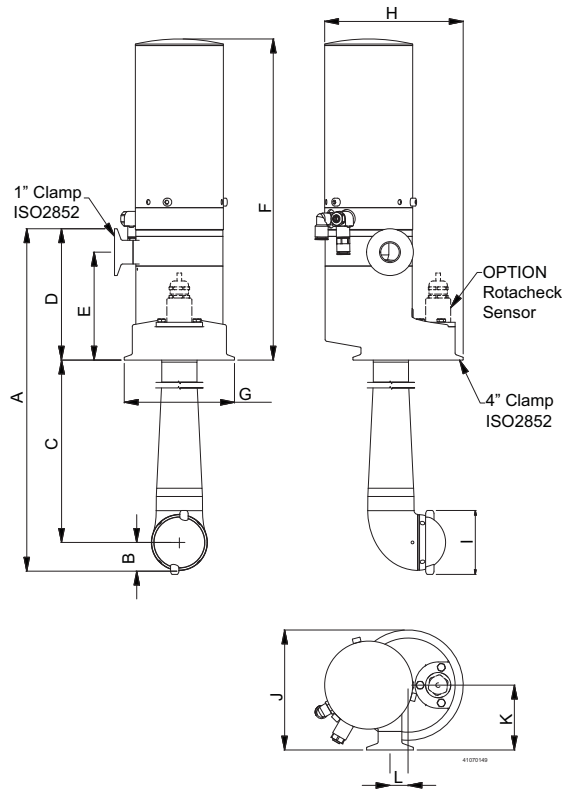

	A	B	C	D	E	F	G	H	I	J	K	L
mm	523 - 673 - 873 - 1173 - 1376 - 1673	31	360 - 500 - 700 - 1000 - 1200 - 1500	142	117	340	Ø119	168	Ø69	130	70	19.5

## TRAX simulation tool

TRAX is a unique software that simulates how the Toftejorg SaniJet 20 performs in a specific tank or vessel. The simulation gives information on wetting intensity, pattern mesh width and cleaning jet velocity. This information is used to determine the best location of the tank cleaning machine and the correct combination of flow, time and pressure to implement. A TRAX demo containing different cleaning simulations covering a variety of applications can be used as reference and documentation for tank cleaning applications. A TRAX simulation is free and available upon request.

### Wetting Intensity

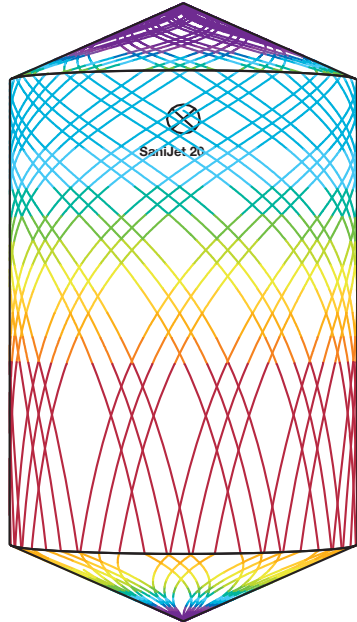
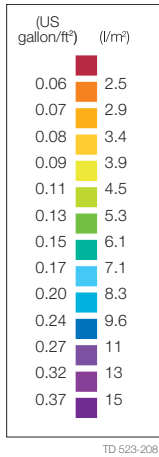

D2m H3m, Toftejorg SaniJet 20, 4 x ø4.2 mm, Time = 1.7 min., Water consumption = 171 l

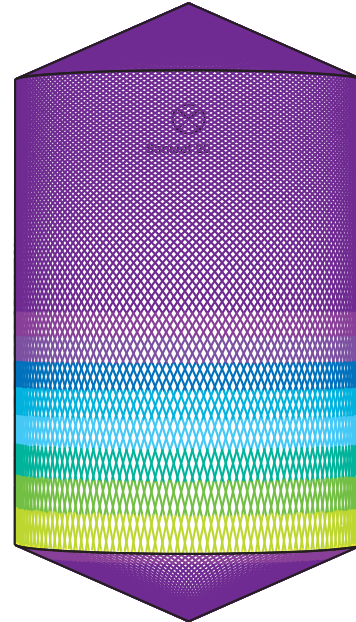

D2m H3m, Toftejorg SaniJet 20, 4 x ø4.2 mm, Time = 7.6 min., Water consumption = 763 l

### Cleaning Pattern, the Golden Section

Toftejorg SaniJet 20 operates according to the patented Golden Section cleaning pattern (EP-Patent No.: 0495883, US-Patent No.: 5,279,675), which is unique in building up a uniform pattern. The pattern starts very coarse and refines itself in a step-less way by laying out the tracks approximately in the middle of the two most distant tracks already made. This means that the jets always clean the areas containing the most remaining product, and thereby remove as much deposit as possible in the shortest possible time. In some instances, this method of cleaning can even render a complete cleaning pattern unnecessary. The Golden Section is the most suitable cleaning pattern for an effective pre-rinse.

Golden Section Cleaning Pattern    Traditional Cleaning Pattern

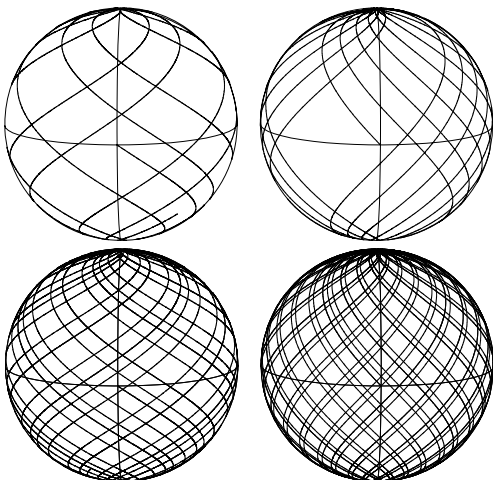

Alfa Laval reserves the right to change specifications without prior notification.

---

**How to contact Alfa Laval**

Contact details for all countries are continually updated on our website. Please visit [www.alfalaval.com](http://www.alfalaval.com) to access the information direct.