



# Instruction Manual

Alfa Laval BladeClean



Covering:  
Standard Machines  
First published: 2015-08

ESE032025-EN1 2015-08

Original manual



<b>EC Declaration of Conformity</b> .....	<b>4</b>
<b>1. Safety</b> .....	<b>5</b>
1.1. Important information .....	5
1.2. Warning signs .....	5
1.3. Safety precautions .....	6
<b>2. Introduction</b> .....	<b>7</b>
2.1. Description .....	7
<b>3. Installation</b> .....	<b>8</b>
3.1. Unpacking/delivery .....	8
3.2. Installation .....	9
3.3. Recycling Information.....	12
<b>4. Operation</b> .....	<b>13</b>
4.1. Operation/Control .....	13
4.2. Troubleshooting.....	14
4.3. Recommended Cleaning .....	15
<b>5. Maintenance</b> .....	<b>16</b>
5.1. General Maintenance.....	16
5.2. General dismantling set up .....	17
5.3. General dismantling .....	18
5.4. Inspection and Service of Components .....	19
5.5. Reassembly .....	20
<b>6. Technical Data</b> .....	<b>21</b>
6.1. Technical Data.....	21
6.2. Performance Data.....	22
6.3. Dimensions .....	23
<b>7. Parts List and Service Kits</b> .....	<b>24</b>
7.1. BladeClean View .....	24
7.2. Assembly Drawings - 1 & 2 .....	25
7.3. Parts List .....	27
7.4. Service Kit .....	28
<b>Appendix A</b> .....	<b>29</b>

# EC Declaration of Conformity

The designated company

Alfa Laval Tank Equipment Inc.

Company name

604 Jeffers Circle – Exton, PA – 19341, United States

Address

+1 610 408 9940

Phone no.

hereby declare that

Tank Cleaning Machine

Denomination

Alfa Laval Gamajet BladeClean

Type

*From serial numbers from BC-001 to BC-XXXX*

is in conformity with the following regulations and directives with amendments:

**- The Machinery Directive 2006/42/EC**

*DS/EN ISO 12100:2011*

**- The Pressure Directive 97/23/EC**

*According to its own volume and the rated pressure range the product is regarded an Article 3, paragraph 3 Equipment*

The person authorised to compile the technical file is the signer of this document.

Executive VP Operations

Title

Andrew Delaney

Name

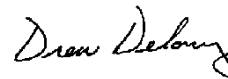

Signature

2015-09-01

Date

Exton, United States

Place



# 1. Safety

---

*Unsafe practices and other important information are emphasized in this manual. Warnings are emphasized by means of special signs.*

***Always read the manual before using the tank cleaning machine!***

---

## 1.1 Important information

---

### WARNING

Indicates that special procedures must be followed to avoid serious personal injury.

### CAUTION

Indicates that special procedures must be followed to avoid damage to the tank cleaning machine.

### NOTE

Indicates important information to simplify or clarify procedures.

---

## 1.2 Warning signs

---

General warning:



Dangerous electrical voltage:



Caustic agents:



# 1. Safety

---

All warnings in the manual are summarized on this page.

Pay special attention to the instructions below so that severe personal injury and/or damage to the tank cleaning machine are avoided.

---

## 1.3 Safety precautions

---

### Installation:

**Always** read the technical data thoroughly. (See chapter 6 Technical Data)



Any tank-cleaning machine can develop a static electricity charge while in operation.



If the tank being cleaned contains a combustible liquid or vapor having a risk of ignition or explosion, it is imperative to have the Alfa Laval BladeClean properly grounded using the provided location on the unit.

---

### Operation:

**Always** read the technical data thoroughly. (See chapter 6 Technical Data)



Necessary precautions must be taken if leakage occurs as this can lead to hazardous situations.

**Always** handle lye and acid with great care.



When an Alfa Laval BladeClean is operating, there should be covers over every tank opening.

These covers should be sealed well enough to withstand the full force of the jet striking the cover plate.

If the cleaning solution were hot, corrosive, or toxic, a leak would present a serious hazard to any personnel in the immediate vicinity or to any exposed electrical equipment.



**Warning: Any tank-cleaning machine can develop a static electricity charge while in operation. If the tank being cleaned contains a combustible liquid or vapor having a risk of ignition or explosion, it is imperative to have the Alfa Laval BladeClean properly grounded using the provided location on the unit.**

---

### Maintenance:

**Always** read the technical data thoroughly. (See chapter 6 Technical Data).



**Never** service the tank cleaning machine when it is hot.

**Always** use Alfa Laval genuine spare parts.

---

### Transportation of the tank cleaning machine:

**Always** drain the tank cleaning machine head and accessories of any liquid

**Always** use original packaging or similar during transportation.

---

## 2. Introduction

---

### 2.1 Description

---

The Alfa Laval BladeClean is a fluid driven machine designed for cleaning the difficult to reach surfaces of an agitator installed in various tanks and vessels. It is powered entirely by water and requires no electricity, compressed air or lubricant for operation. It has minimal moving parts and works on a simple spring mechanism. The water entering through the inlet lifts a plunger upwards against the spring force this allows a cone of water to impact the agitator. At lower pressures the plunger is retracted by the spring, closing the flow. In the closed position the plunger is flush with the outlet which prevents any debris from entering the Alfa Laval BladeClean. A positive metal stop is provided to prevent the plunger from being pushed down when the load of material within the tank would be acting on the top of the Alfa Laval BladeClean. A complete description of the technical specifications and construction of the stainless steel Alfa Laval BladeClean can be found ahead in the manual.

---

## 3. Installation

---

### 3.1 Unpacking/delivery

---

#### Step 1

**CAUTION**

Alfa Laval cannot be held responsible for incorrect unpacking.

Check the delivery for:

1. Complete Cleaning Machine
  2. Delivery note
- 

#### Step 2

Remove any packing material.

---

#### Step 3

Inspect the tank cleaning machine for visible transport damage.

Inspection!

---



## 3. Installation

---

*Read the instructions carefully and pay special attention to the warnings! Always check the tank cleaning machine before operation.*

---

### 3.2 Installation

---

#### Step 1



Always read the technical data thoroughly.

(See chapter 6 Technical Data)

---

#### Step 2

##### Assembly

Every Alfa Laval Tank Cleaning Product is operationally tested before shipment and is ready to run after unpacking. No assembly is required prior to use. The Alfa Laval Tank Cleaning Product has been configured to meet the operating conditions (for the Alfa Laval Tank Cleaning Product, not at the pump) given to us, e.g. pressure, flow, temperature, cycle time, etc.

**Note:** Any change to the originally supplied operating conditions will affect the performance of the Alfa Laval Tank Cleaning Product accordingly.

---

#### Step 3

##### Inlet Connections

The Alfa Laval BladeClean has a 1" tri clover connection on the inlet side. Custom sanitary connections are also available.

---

#### Step 4

##### Mounting

Before mounting the Alfa Laval BladeClean, make sure the supply line has been adequately flushed. The Alfa Laval BladeClean shall be mounted on a rigid 1" tube using the tri clamp connection. In most applications, the Alfa Laval BladeClean will be mounted in the upright position (outlet connection pointing up), but it can be mounted in any orientation. The standard weld adapter (Hygienic Tank Connection) is provided in the kit. This adapter will help mount the Alfa Laval BladeClean at the bottom of the tank. Refer to Appendix A for installation instructions for HTC. The Alfa Laval BladeClean is not optimized for horizontal mounting and will not give the same impact. In the horizontal position, the cone of impact will not cover much of the agitator blades and optimal cleaning may not be achieved.

---

#### Step 5

##### Location inside Tank

The Alfa Laval BladeClean should be placed below the agitator blades. The cone of impact has a tangential force at the point of impact on the blade. This force cleans the area surrounding the exact impact cone. Depending on the length of the blade, more than one Alfa Laval BladeClean may need to be installed for sufficient cleaning. As seen from the performance graphs (Chapter 6), depending on the pressure, the Alfa Laval BladeClean has a wetting distance of more than 6 feet (1.83 m). This allows second level agitator blades to possibly get cleaned using only one machine.

---

## 3. Installation

---

*Read the instructions carefully and pay special attention to the warnings! Always check the tank cleaning machine before operation.*

---

### Step 6

#### Entry Openings

The Alfa Laval BladeClean should be placed at the bottom of the tank. Entry openings should be provided to accommodate the weld adapter attached to the Alfa Laval BladeClean. Depending on the position of the agitator blades, the mounting location of the Alfa Laval BladeClean should be adjusted.

**Note:** When in operation, the plunger of Alfa Laval BladeClean rises above the tank bottom to a height of about **5-7 mm**. This might interfere with low level scrapers in certain tanks. Consult the nearest Alfa Laval office for more information.

---

### Step 7

#### Vessel Drainage

It is necessary to clean the floor of a vessel, standing liquid will diminish the effectiveness of the Alfa Laval BladeClean. Wherever possible, the tank floor should be pitched toward the drain and the drainage opening should be large enough to eliminate or reduce any liquid buildup or puddling. If gravity alone is insufficient, a scavenger or suction pump should be connected to the drain to suck out the excess wash fluid. If not drained, the water might accumulate and rise above the Alfa Laval BladeClean outlet, hampering the Alfa Laval BladeClean's performance.

---

### Step 8

#### Filters and Strainers

All tank cleaning systems should be equipped with a filter or strainer that will trap solids 1/16" (1.6 mm) or larger, as these will clog the Alfa Laval BladeClean. These large particles will not harm the machine, but they can become caught in one of the internal passages. This would cause a reduction of its cleaning effectiveness due to a loss of flow. Disassembly of the Alfa Laval BladeClean then becomes a necessity to remove the blockage. In recirculating (closed-loop) cleaning or any other application where the cleaning solution may carry abrasive solids in suspension, adequate filtration is a must. These particles can be extremely destructive to the Alfa Laval BladeClean, pumps, valves, and other system components. Filters, properly installed and maintained, will more than pay for themselves with lower overall operating costs in these applications. Furthermore, to ensure that clogged filters or strainers are cleaned, we recommend using automatic self-cleaning models.

---

### Step 9

#### Capacity of Supply Pump

The Alfa Laval BladeClean can be used with either a centrifugal or positive displacement (constant volume), PD, style pump. The Alfa Laval BladeClean is tested for performance upto 150 Psi (10.3 Bar) and it can be operated at higher pressures as well depending upon sufficient drainage so as to avoid puddling. If the Alfa Laval BladeClean is to be used with a centrifugal pump, the end user must take all of the plumbing, elevation, and Alfa Laval BladeClean pressure/flow rate requirements into account. If PD style pumps (i.e. piston pump, plunger pump, or mechanical diaphragm pump, etc.) will supply the wash fluid to the Alfa Laval BladeClean, a different set of rules will apply. PD pumps are fixed volume pumps whose flow rate is dependent upon the speed of the pump; the pumps also have a pressure rating which is the maximum operating pressure.

**Note:** Do not confuse the maximum operating pressure of a PD pump with the actual operating pressure. The actual operating pressure is dictated by the fixed flow rate of the pump and the plumbing system.

---

### 3. Installation

---

*Read the instructions carefully and pay special attention to the warnings! Always check the tank cleaning machine before operation.*

---

#### **Step 9**

#### **Safety**

**WARNING:** When Alfa Laval Tank Cleaning Products are operating, there should be covers over any tank openings. These covers should be sealed well enough to withstand the full force of the water striking the cover plate. If the cleaning solution is hot, corrosive, or toxic, a leak would present a serious hazard to any personnel in the immediate vicinity or to any exposed electrical equipment.

Any tank-cleaning machine can develop a static electric charge while in operation. If the tank being cleaned contains a combustible liquid or vapor having a risk of ignition or explosion, it is imperative to have the Alfa Laval Tank Cleaning Product properly grounded.

---

## 3. Installation

---

*Read the instructions carefully and pay special attention to the warnings! Always check the tank cleaning machine before operation.*

---

### 3.3 Recycling Information

---

#### • Unpacking

- Packing material consists of wood, plastics, cardboard boxes and in some cases metal straps.
- Wood and cardboard boxes can be reused, recycled or used for energy recovery.
- Plastics should be recycled or burnt at a licensed waste incineration plant.
- Metal straps should be sent for material recycling.

#### • Maintenance

- All metal parts should be sent for material recycling.

#### • Scrapping

- At end of use, the equipment must be recycled according to relevant, local regulations. Beside the equipment itself, any hazardous residues from the process liquid must be considered and dealt with in a proper manner. When in doubt, or in the absence of local regulations, please contact your local Alfa Laval sales company.
-

## 4. Operation

---

*Read the instructions carefully and pay special attention to the warnings! Always check the tank cleaning machine before operation.*

---

### 4.1 Operation/Control

---

#### Step 1



Always read the technical data thoroughly. See chapter 6 Technical Data

#### CAUTION

Alfa Laval cannot be held responsible for incorrect operation/control.

---

#### Step 2



Never touch the tank cleaning machine or the pipelines when pumping hot liquids.

---

#### Step 3

#### Initial Startup

Every Alfa Laval BladeClean that ships is accompanied by a Birth Certificate. This document indicates how the Alfa Laval BladeClean performed in our testing tank before it shipped based on the operating conditions supplied to Alfa Laval Tank Equipment Inc. To ensure the longest possible life of the Alfa Laval Bladeclean, please verify the operating conditions.

---

## 4. Operation

---

*Pay attention to possible faults*

*Read the instructions carefully.*

---

### 4.2 Troubleshooting

---

**Note:** Part numbers appearing below may be used to identify parts in the exploded views in Chapter 7.

- WATER LEAKING OUT OF THE BOTTOM CAP

The Alfa Laval BladeClean has a seal (9) on the main body (7) to prevent any water from going down into the bottom cap (10). If water is seen leaking from the weep holes on the bottom cap, check this seal for any damage. If damaged, replace the seal with a new one. If not the seal, check the bearings (5) for any damages.

- PLUNGER NOT RECESSING

If the plunger does not operate smoothly, check the wave spring (14) in the bottom cap for any damage. Try running clean water through the Alfa Laval BladeClean to get rid of any debris causing the trouble. The O-ring on the plunger could also be getting in the way of the plunger; replace it if needed.

- POOR CLEANING PERFORMANCE

Check the flow and pressure at the Alfa Laval BladeClean inlet under actual operating conditions. Make sure to refer the pressure-flow table to reconfirm the operating conditions. Insufficient pressure may result from line losses when the machine is located far from the pump, so the line size must be increased accordingly for long runs.

Verify that the cleaning solution is the correct compound and in the concentration needed for the deposit being cleaned. If heating is necessary, also check that the solution is at the proper temperature.

Unscrew the Alfa Laval BladeClean and inspect for any debris. Determine if the deposit being cleaned requires greater impact or longer impact time for more thorough scrubbing. Contact Alfa Laval Tank Equipment Inc. for assistance, if needed.

Ensure that the vessel drains the effluent or used wash fluid at an equal or faster rate being sprayed in through the Alfa Laval BladeClean. Make sure the water collected is not covering the Alfa Laval BladeClean outlet, thus blocking the spray. The floor of the vessel should be sloped or pitched toward the drain and the drainage opening should be large enough to gravity-drain the effluent from the vessel. If you still have puddling, use some form of pump to suck out the effluent.

---

## 4. Operation

---

The Tank Cleaning machine is designed for cleaning in place (CIP). CIP = Cleaning In Place. Study the instructions carefully and pay special attention to the warnings! NaOH = Caustic Soda, HNO<sub>3</sub> = Nitric Acid.

---

### 4.3 Recommended Cleaning

---

#### Step 1



Always handle lye and acid with great care.

Caustic danger!



Always use rubber gloves!



Always use protective goggles!

---

#### Step 2



Never touch the pump or the pipelines when sterilizing.

Danger of burns!

---

#### Step 3



Always rinse well with clean water after using a cleaning agent.

Always rinse!

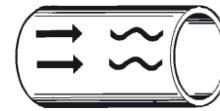

Clean Water    Cleaning agent

---

#### NOTE

Cleaning agents must be stored/disposed of in accordance with current regulations/directives.

## 5. Maintenance

---

*Maintain the Tank Cleaning Machine with care. Read the instructions carefully and pay special attention to the warnings!  
Always keep Minor spare parts kit in stock.*

---

### 5.1 General Maintenance

---

Step 1



Always read the technical data thoroughly. (See chapter 6 technical Data).

---

Step 2

Recommended spare parts:

Order service kits from the service kits list

(See 7.4 Minor Service Kit & 7.5 Major Service Kit)

Ordering spare parts:

Contact your local Alfa Laval Sales Company.

---



## 5. Maintenance

---

*Maintain the Tank Cleaning Machine with care. Read the instructions carefully and pay special attention to the warnings! Always keep Minor spare parts kit in stock.*

---

### 5.2 General Dismantling Set Up

---

#### Step 1

##### NOTE

A rigorously implemented preventative maintenance program will significantly reduce repair costs over the life of the Alfa Laval BladeClean. The foundation of such a program is regularly scheduled inspections to discover and replace worn or damaged parts before they can cause the failure of other, more costly, components. The inspection intervals required will depend on the severity of the application, but 100 hours of operation is recommended initially.

---

#### Step 2

##### STORAGE

The Alfa Laval BladeClean should be washed out with clean water after each use to remove any foreign material or soft substances left in the machine that may harden during storage. A clean water rinse through the Alfa Laval BladeClean will also wash out any residues of chemical cleaners or recirculated wash water that could adversely affect the seals and O-rings during prolonged contact in storage. The best position to store the Alfa Laval BladeClean is standing upward with the outlet connection facing up.

---

#### Step 3

##### INSPECTION INTERVALS

An interval of 100 hours is recommended initially. If all of the components are found to be in acceptable condition after the first 100 hours, the Alfa Laval BladeClean may then be inspected and routine preventive maintenance should be performed every 500 hours of operation, depending on the severity of use.

---

#### Step 4

##### TIPS

All the Bearings, Bushings, Seals and O-rings are wear parts. Ideally, they should all be replaced, as a group, every 500 hours of operation, depending on the severity of use. If just one Bearing or Seal is worn or damaged, replace both it and its mate, not just the worn or damaged part.

---

## 5. Maintenance

---

*Maintain the Tank Cleaning Machine with care. Read the instructions carefully and pay special attention to the warnings! Always keep Minor spare parts kit in stock.*

---

### 5.3 General Dismantling

---

#### Step 1

Place a soft towel or an equivalent under the Alfa Laval BladeClean assembly to prevent it from getting scratched. Use a towel to hold the body extension tube.

---

#### Step 2

Remove the Bottom Cap (10) using the 18" (457.2 mm) long Adjustable Crescent Wrench. After the cap comes off, use the 3/8" (9.5 mm) Allen Screw T Handle to unscrew the Screw (13) from the Retainer (12), which holds the Plunger (11) and the Wave Spring (14) together. After removing each part, place them aside for inspection and reassembly.

**WARNING:** The spring is under compression and may cause harm if not unscrewed with care.

---

#### Step 3

The Plunger (11) will slide out now. The Main Body (7) has a Bearing (5) and an O-ring (8) mounted, which can be removed to check for damages. The Main Body, Body Extension Tube (1) and the Outlet screw (4) all can be unscrewed manually. A bench vise and adjustable crescent wrench can be used if needed. The various O-rings and gaskets should be removed for inspection.

---

## 5. Maintenance

---

*Read the instructions carefully. The items refer to the parts list and service kits section.*

---

### **5.4 Inspection and Service of Components**

---

#### **Drawing 1 & 2**

Inspect all machined features and windows to be sure they are clear and free of debris. Especially check for debris in slots of outlet screw (4).

Inspect the O-rings and the bearings (5) for deterioration (hardening or deformation) or damage and replace if necessary.

Replace the seal (9) if damaged during operation or disassembly or doesn't fit on the plunger correctly.

Check the wave springs (14) and replace if any crests are damaged.

---

## 5. Maintenance

---

*Read the instructions carefully. The items refer to the parts list and service kits section.*

---

### 5.5 Reassembly

---

#### General Notes

**All parts must be cleaned thoroughly before reassembling.** Any deposits remaining on the parts can cause difficult disassembly the next time the Alfa Laval BladeClean needs servicing.

Assemble each O-rings using water for lubrication. This will allow each O-ring to be compressed uniformly in each threaded joint assembly.

---

#### Drawing 1

Start with the upper assembly. Press fit the bearing (5) into the outlet screw (4). Place the gasket (3) at the bottom of (4). Place the (4) into the Body Tube (1). Place the O-ring (2) into the extension tube (1). Screw the outlet screw (4) in the extension tube (1).

---

#### Drawing 2

Place the seal (8) in the main body (7). Press fit the bearing (5) from the bottom into the main body. Screw the main body below the extension tube. Place the O-ring (12) on the plunger (11). Insert the plunger (11) through the top of outlet screw (4) all the way down. Place the spring (14) in position below the main body (7) and screw in the Retainer (12) with (13).

---

#### Drawing 1

Make sure the plunger moves smoothly in the body and then place the Bottom Cap (10). Put on the O-ring (6) on the outside of outlet screw (4). Now the Alfa Laval BladeClean can be attached to the tank adapter (15) with the clamp (16) provided.

---

This completes the assembly process.

## 6. Technical Data

---

*It is important to observe the technical data during installation, operation and maintenance. Inform personnel about the technical data.*

---

### 6.1 Technical Data

---

The Alfa Laval BladeClean Tank Cleaning Machine is a highly efficient machine at a range of pressures and flows. The instruction manual is part of the delivery. Read the instructions carefully.

#### TECHNICAL DATA

Lubricant . . . . . Self- lubricating  
Max. throw length . . . . . 6-9 m (20 - 30 ft.)

#### Pressure

Working pressure . . . . . 1.5 - 10 bar (22 - 145 PSI)  
Recommended pressure . . . . . 2 - 5 bar (29 - 73 PSI)

#### Certificate

Material Certificate

#### PHYSICAL DATA

##### Materials

1.4404 (316L), FDA- approved EPDM, PTFE, PPS

Weight . . . . . 1.27 kg (2.8 lbs.)  
Surface finish . . . . . 0.5 µm (20 Ra)

##### Connections

Standard thread . . . . . 1" tri- clamp standard Alfa Laval connection  
Available option . . . . . 1½" tube weld on

##### Includes

Mounting materials . . . . . Alfa Laval Hygienic Tank Adapter, EPDM O-Ring, Clamp, Blind Cap

---

## 6. Technical Data

It is important to observe the technical data during installation, operation and maintenance. Inform personnel about the technical data.

### 6.2 Performance Data

Flow Rate

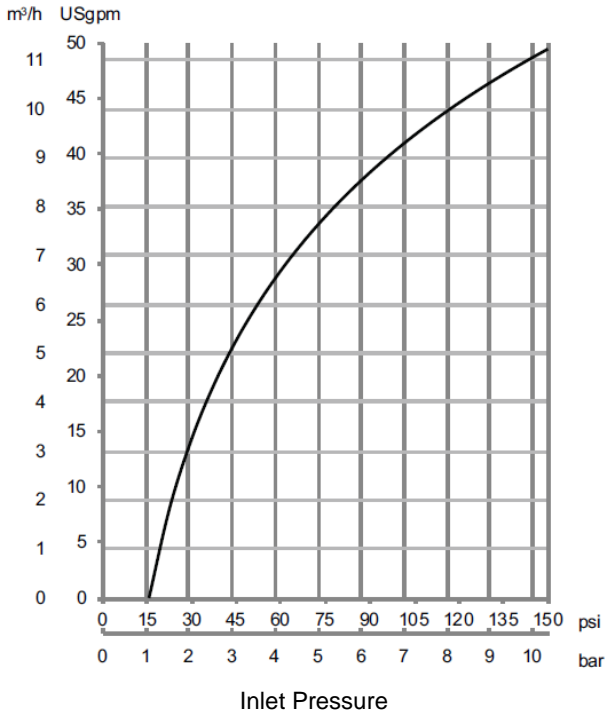

Impact Throw Length

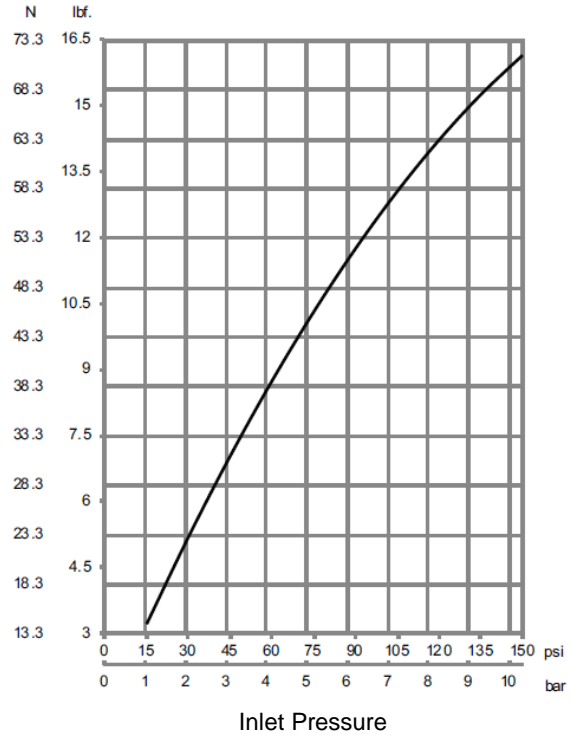

Cone of Impact

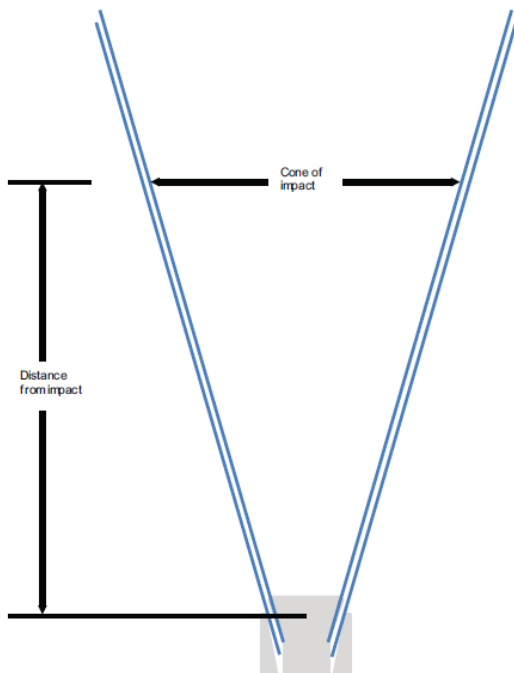

Distance from target (mm/ inch)	Diameter (mm/ inch)
21/ 1	64/ 2.5
51/ 2	102/ 4
102/ 6	139/ 5.5
305/ 12	178/ 7
457/ 18	379/ 11
610/ 24	318/ 12.5
914/ 36	432/ 17
1219/ 48	622/ 30
1254/ 60	889/ 30
1828/ 72	914/ 36

## 6. Technical Data

*It is important to observe the technical data during installation, operation and maintenance. Inform personnel about the technical data.*

### 6.3 Dimensions

#### Dimensions

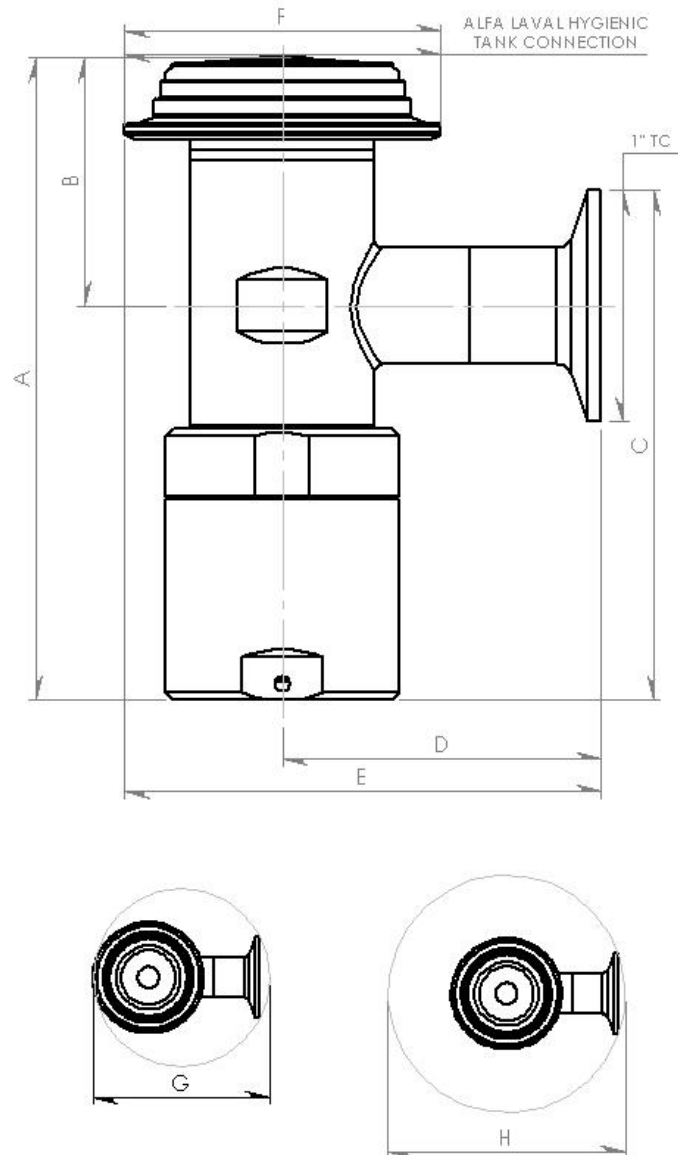

#### Dimensions

	A	B	C	D	E	F
mm	140	53	112	68	104	68
in	5.5	2.1	4.4	2.7	4.1	2.7

## 7. Parts List and Service Kits

*The drawing shows Alfa Laval BladeClean Tank Cleaning Machine*

### 7.1 BladeClean View

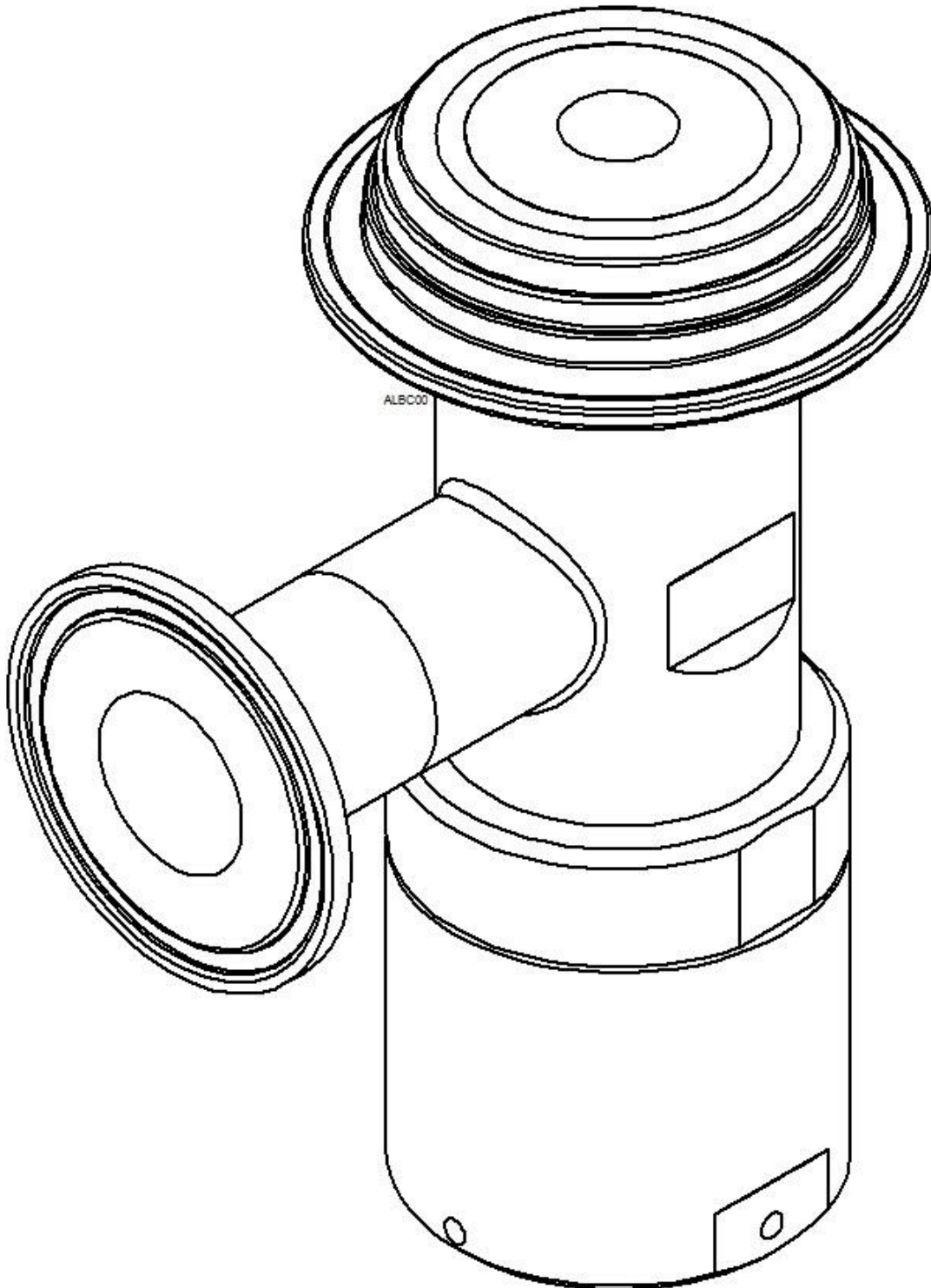



## 7. Parts List and Service Kits

The drawing shows Alfa Laval BladeClean Tank Cleaning Machine

### 7.2 Assembly Drawings - 1 & 2

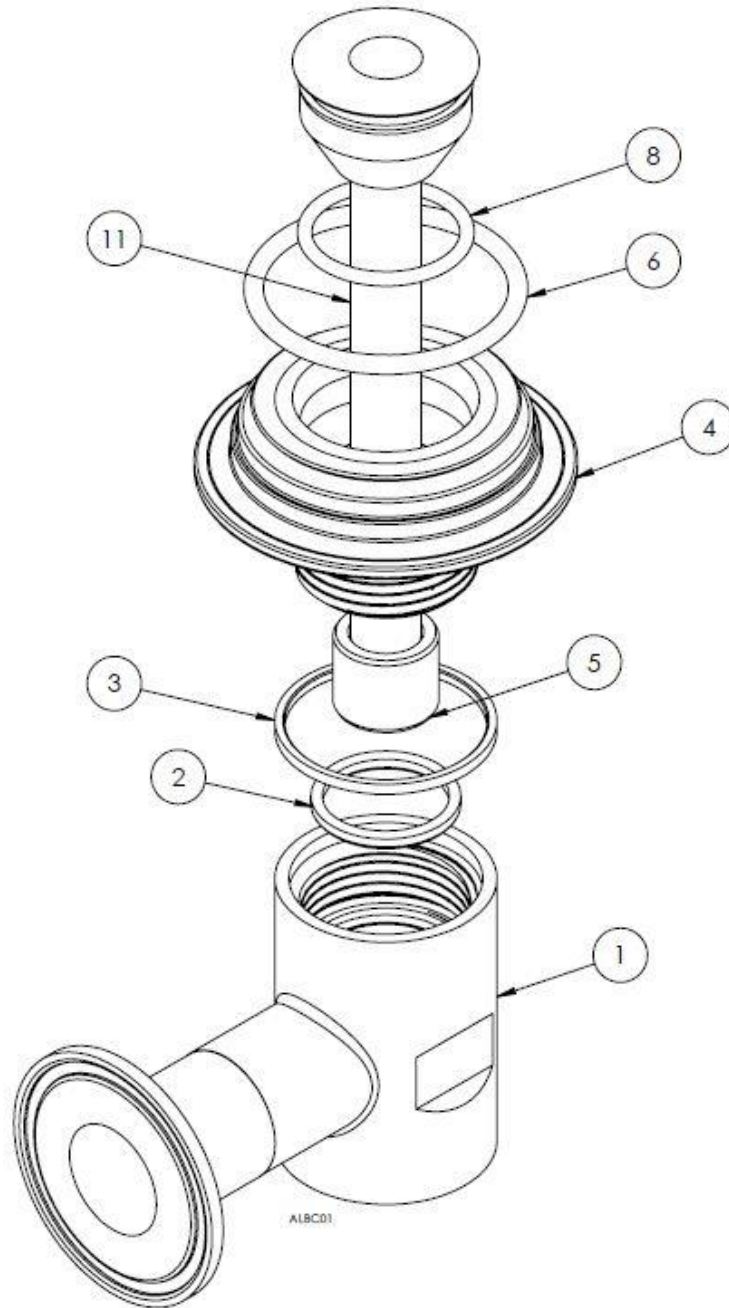

Drawing 1: Alfa Laval Bladeclean Assembly Exploded View

## 7. Parts List and Service Kits

The drawing shows Alfa Laval BladeClean Tank Cleaning Machine

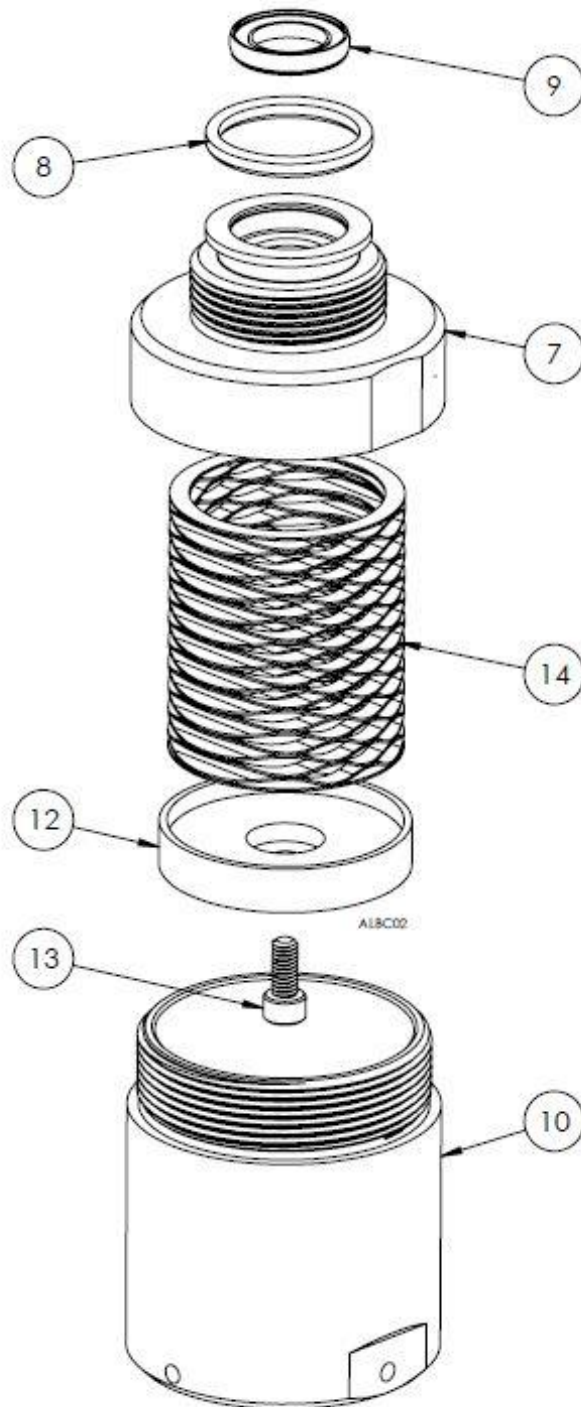

Drawing 2: Alfa Laval BladeClean Assembly Exploded View

## 7. Parts List and Service Kits

### 7.3 Parts List

Pos.	AL No.	Gamajet No.	Description	No.
1	9614699602	AG-556	BODY EXTENSION TUBE	1
2	9614661603	401170	O- RING, EPDM, 2-022	1
	9614661602	411060	O- RING, VITON, 2-022	1
	9614661604	401180	O- RING, ZALAK, 2-022	1
3	TE52D561	TE52D561	OUTLET GASKET, OUTSIDE	1
4	9614699603	AG-552	OUTLET, SCREW ON, 1" BSPT	1
5	9614699604	AG-567	BEARING	2
6	9614699617	AG-570	TANK ADAPTER O- RING, EDPM	1
	9614699618	AG-570-V	TANK ADAPTER O- RING, VITON	1
	9614699619	AG-570-K	TANK ADAPTER O- RING, KALREZ	1
7	9614699605	AG-555	MAIN BODY	1
8	9614699606	AG-559	O- RING, EPDM, 2-118	2
	9614699620	AG-559-V	O- RING, VITON, 2-118	2
	9614699621	AG-559-K	O- RING, KALREZ, 2-118	2
9	9614699607	AG-569	SHAFT SEAL	1
10	9614699608	AG-558	BOTTOM CAP	1
11	9614699609	AG-501	PLUNGER	1
12	9614699611	AG-557	RETAINER, CREST TO CREST WAVE SPRING	1
13	9614699612	AG-560	SHCS, 8-32 X 3/8" 316 SS	1
14	9614699613	AG-563	CREST-TO-CREST WAVE SRING, DESIGN No. 37083	1
15	9614070801	9614070801	TANK ADAPTER	1
16	9612939303	9612939303	CLAMP	1

## 7. Parts List and Service Kits

### 7.4 Service Kit

Article no: 9614699616 ALFA LAVAL GJ BLADECLEAN KIT - EPDM				
Pos. no.	Part No.	Gamajet Part No.	Description	No.
2	9614661603	401170	O-RING, EPDM, 2-022	1 pcs.
8	9614699606	AG-559	O-RING, EPDM, 2-118	2 pcs.
9	9614699607	AG-569	SHAFT SEAL	1 pcs.
6	9614699617	AG-570	TANK ADAPTER, O-RING, EPDM	1 pcs.
3	TE52D561	TE52D561	OUTLET GASKET, OUTSIDE	1 pcs.
5	9614699604	AG-567	BEARING	2 pcs.

Article no: 9614699622 ALFA LAVAL GJ BLADECLEAN KIT - VITON				
Pos. no.	Part No.	Gamajet Part No.	Description	No.
2	9614661602	401160	O-RING, VITON, 2-022	1 pcs.
8	9614699620	AG-559-V	O-RING, VITON, 2-118	2 pcs.
9	9614699607	AG-569	SHAFT SEAL	1 pcs.
6	9614699618	AG-570-V	TANK ADAPTER, O-RING, VITON	1 pcs.
3	TE52D561	TE52D561	OUTLET GASKET, OUTSIDE	1 pcs.
5	9614699604	AG-567	BEARING	2 pcs.

Article no: 9614699623 ALFA LAVAL GJ BLADECLEAN KIT - KALREZ				
Pos. no.	Part No.	Gamajet Part No.	Description	No.
2	9614661604	401180	O-RING, ZALAK, 2-022	1 pcs.
8	9614699621	AG-559-K	O-RING, KALREZ, 2-118	2 pcs.
9	9614699607	AG-569	SHAFT SEAL	1 pcs.
6	9614699619	AG-570-K	TANK ADAPTER, O-RING, KALREZ	1 pcs.
3	TE52D561	TE52D561	OUTLET GASKET, OUTSIDE	1 pcs.
5	9614699604	AG-567	BEARING	2 pcs.

# Appendix A

## Appendix A - Hygienic Tank Connection Installation

**Warning - Install the device only when depressurized and temperature is cooled.**

**This device may only be installed by qualified technical personnel who has read and understood the instruction manual!**

### Welding recommendations

**Note:** To ensure a hygienic weld, either the use of shielding gas or the pre-treatment of the welding zone to remove any discoloration is recommended. Tank adapter (15) thickness at welding zone is 6 mm (0.236”).

1. Cut a hole in the desired tank sized to the adapter diameter plus 1 mm (0.039”) maximum.
2. Chamfer the outer edges by 45 degrees, leaving a 1-2 mm (0.039”-0.078”) recess toward the inside of the vessel.
3. Align the inside of the tank adapter with the inside of the tank wall. If mounting on a non-horizontal wall, turn the adapter such that it is oriented with the leakage hole pointing downwards.
4. Using appropriate filler, tack weld the adapter to the tank in positions 1 and 2 as shown (Image 1). Ensure the adapter is level; adjust if needed, and then tack weld it at positions 3 and 4.
5. Continue tack welding the adapter at positions 5 through 8 as shown (Image 2).
6. Allow the adapter and welded areas to cool, using compressed air to speed the process as needed. Do not quench with water, as this may cause warping due to material shrinkage.
7. Weld between positions 2 and 7 from the outside, and then cool the region using compressed air. Continue welding between the tack weld points as shown (Image 3): between positions 1 and 8; then positions 3 and 7; positions 4 and 8; positions 3 and 5; positions 2 and 6; and finally positions 1 and 5.
8. Allow the region to cool, then repeat the cross-welding pattern described in step 7, except weld from the inside of the tank.
9. Once the welding is complete, allow the weld plate to cool completely to room temperature. Do not quench the area with water, in order to avoid material warping.
10. Finish the inside of the tank (and the outside, if desired) by grinding and polishing until flush with the wall. Be sure to allow the area to cooling between grinding and polishing.

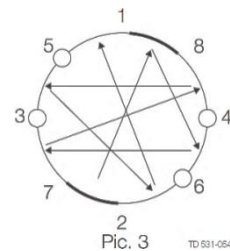
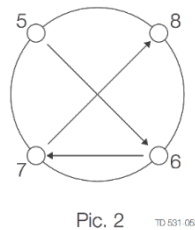
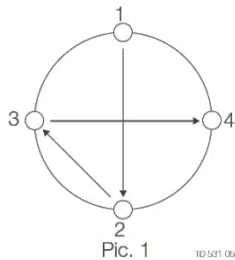

### Mounting instrumentation

The HTC carries the EHEDG symbol and is authorized to carry the 3-A symbol. Both symbols are only valid when appropriate instrumentation connections are used together with this process connection. The instrumentation connection that fits this adapter is the Alfa Laval HTC connection, male part. For other information contact your local Alfa Laval office.

- Mount the O-ring gasket (5) that fits the BladeClean connections (or blind cap) O-ring groove.
- Insert the Alfa Laval BladeClean (or blind cap) into the Tank Adapter.
- Put the clamp (16) around the assembly point and tighten the bolt to apply pressure until metal-to-metal contact in the connection is achieved.

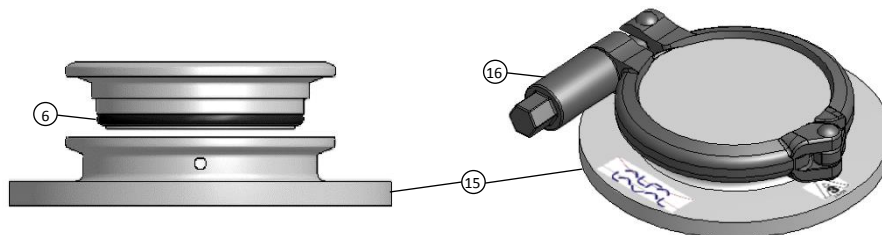

**How to contact Alfa Laval**

Contact details for all countries are continually updated on our website.

Please visit [www.alfalaval.com](http://www.alfalaval.com) to access the information directly.

© Alfa Laval Corporate AB

This document and its contents is owned by Alfa Laval Corporate AB and protected by laws governing intellectual property and thereto related rights. It is the responsibility of the user of this document to comply with all applicable intellectual property laws. Without limiting any rights related to this document, no part of this document may be copied, reproduced or transmitted in any form or by any means (electronic, mechanical, photocopying, recording, or otherwise), or for any purpose, without the expressed permission of Alfa Laval Corporate AB. Alfa Laval Corporate AB will enforce its rights related to this document to the fullest extent of the law, including the seeking of criminal prosecution.